



## MORPHOMETRIC ANALYSIS OF METACARPAL AND METATARSAL BONES OF CAVE BEARS (CARNIVORA, URSIDAE)

GENNADY F. BARYSHNIKOV<sup>1,\*</sup>, ANDREY YU. PUZACHENKO<sup>2</sup>

<sup>1</sup> Zoological Institute, Russian Academy of Sciences, Universitetskaya nab. 1, 199034 Saint Petersburg, Russia; e-mail: g\_baryshnikov@mail.ru.

<sup>2</sup> Institute of Geography, Russian Academy of Sciences, Staromonetnyi per. 29, 109017 Moscow, Russia; e-mail: andreyuzak@gmail.com.

\*corresponding author

Baryshnikov, G. F., Puzachenko, A. Yu. (2017): Morphometric analysis of metacarpal and metatarsal bones of cave bears (Carnivora, Ursidae). – Fossil Imprint, 73(1-2): 7–47, Praha. ISSN 2533-4050 (print), ISSN 2533-4069 (on-line).

**Abstract:** For the first time, morphometric variation has been studied in metacarpal and metatarsal bones of all known taxa of cave bears, which belong to different molecular genetic groups (*deningeri*, *kudarensis*, *spelaeus*, and *ingressus* haplotypes). The examined material involves nearly three thousand specimens from 28 localities of Europe, the Urals, Caucasus, and Central Asia. For comparison we used samples of fossil and recent *Ursus arctos*, as well as *U. etruscus*, regarded as a common ancestor of brown bears and cave bears. Methods of univariate and multivariate statistical analyses of metapodial bones were employed, providing an opportunity to ascertain the degree of sexual dimorphism in different taxa, the degree of morphological difference between taxa, and to define “size” and “shape” morphospaces for concise description of morphological diversity and classification of cave bears. Our study reveals that, on average, sexual dimorphism is more pronounced in *U. arctos* and *U. kudarensis praekudarensis* than in cave bears. Sexual dimorphism of bear metapodia is greater than sexual dimorphism of the skull (Baryshnikov and Puzachenko 2011). The contribution of sexual dimorphism to size of the metapodials is close to a contribution associated with morphological disparity between the bears belonging to different taxa. By the example of two chronosubspecies of Kudaro cave bear: *U. kudarensis praekudarensis* from Middle Pleistocene and *U. k. kudarensis* from Late Pleistocene, we succeeded in detecting a decrease of sexual dimorphism over time, which suggests that earlier cave bears inherited a pronounced sexual dimorphism from ancestral taxa. Metacarpal and metatarsal bones of cave bears are easily distinguished from those of *U. etruscus* and *U. arctos*, simultaneously demonstrating similarity between cave bears from different genetic groups, involving the species *U. kudarensis* (the basal taxon for all cave bears, including *U. deningeri*); some peculiarities of these bones are revealed only in the smaller *U. rossicus*. The examples have shown the presence (*U. k. kudarensis*) as well as absence (*U. deningeri*, *U. kanivetz ingressus*) of evident spatial (geographical) and temporal patterns in metapodial variability. It is determined that taxa can be better differentiated by metacarpals rather than by metatarsals, because the latter proved to be more “conservative” and less variable over time. It is hypothesized that very rapid modification of metapodial bones occurred at an early stage of evolution of this group, which was presumably a result of occupation of a special ecological niche by cave bears. This study reveals that the size and shape of metacarpal and metatarsal bones did not have an observable link with the taxonomic or evolutionary position of cave bears. At the same time, the clear morphological differences between brown bears and cave bears reflect an early evolutionary divergence between “arctoid” and “spelaeoid” lineages.

**Key words:** *Ursus*, cave bears, morphometrics, variations, metacarpals and metatarsals, evolution, adaptation, Pleistocene

Received: November 4, 2016 | Accepted: May 31, 2017 | Issued: August 15, 2017

### Introduction

Fossil remains of cave bears (subgenus *Spelearctos* GEOFFROY SAINT HILAIRE, 1833 of the genus *Ursus* LINNAEUS, 1758) are known from numerous Pleistocene localities of Europe and Caucasus, as well as from Siberia and Tien Shan (Baryshnikov 2007). These large animals inhabited forest, forest-steppe, and steppe landscapes, occurring in mountains up to the Alpine belt.

Recent studies show significant genetic diversity of cave bears. Analyses of the ancient mtDNA revealed three evolutionary lineages for the Late Pleistocene, which are frequently regarded as separate species (Rabeder et al. 2010, Knapp et al. 2009, Stiller et al. 2014): *Ursus spelaeus* ROSENMÜLLER, 1794 (Western Europe and Western Siberia), including subspecies *U. s. eremus* RABEDER et al., 2004 (Alps and Altai Mountains) and *U. s. ladinicus* RABEDER et al., 2004



**Text-fig. 1.** Fifth metatarsal (mtt V) of *Ursus rossicus* (a) and *U. kudarensis praekudarensis* (b); dorsal views. a – ZIN 28601-331, Kizel Cave, Urals; b – ZIN 37993-28, Kudaro 1 Cave (layer 5), Caucasus.

(Alps), *U. ingressus* RABEDER et al., 2004 (Eastern Europe), and *U. kudarensis* BARYSHNIKOV, 1985 including subspecies *U. k. praekudarensis* (BARYSHNIKOV, 1998) (Caucasus, and probably Northern Siberia).

*U. ingressus* was found to be grouped with findings from Medvezhiya Cave (= Medvezh'ya Cave) in Northern Ural (Knapp et al. 2009, Baca et al. 2012, Stiller et al. 2014); this cave represents terra typica for *Ursus spelaeus kanivetz*

(Vereshchagin 1973: 928). This name has priority, and therefore the species, according to rules of International Code of Zoological Nomenclature, should be denominated *Ursus kanivetz* VERESHCHAGIN, 1973 (= *ingressus*). The cave bears from Urals localities, Bol'shoy Glukhoy Grotto and Serpievskaya Cave also belong to "ingressus" haplogroup (Stiller et al. 2014). A craniometrical difference was detected between populations from Eastern Europe and Urals (Baryshnikov and Puzachenko 2011); hence, we analyzed two separate geographical samples: *U. k. kanivetz* (Urals) and *U. k. ingressus* (Eastern Europe up to Volga River).

There is also the chronospecies *U. deningeri* VON REICHENAU, 1904 from the Middle Pleistocene, which is regarded as the ancestor of *U. spelaeus* and *U. kanivetz* (= *ingressus*). This has been confirmed by molecular data (Valdiosera et al. 2006, Dabney et al. 2013). One more species, *U. rossicus* BORISSIAK, 1930 (including *U. uralensis* VERESHCHAGIN, 1973), represents the smallest cave bear in the Middle and Late Pleistocene of Eastern Europe, Urals and Western Siberia (Text-fig. 1). According to mitochondrial evidence, it occupies the basal position in the lineage of *ingressus* (Stiller et al. 2014), but is morphologically peculiar (Baryshnikov and Puzachenko 2011). Baryshnikov (2007) united *U. rossicus* with *U. savini* ANDREWS, 1922 (described from the Middle Pleistocene of England), and later included into this group of small cave bears the taxon *U. savini nordostensis* BARYSHNIKOV, 2011, described from the north of Eastern Siberia (Sher et al. 2011). Rabeder et al. (2010) assumed *U. savini* could belong to cave bears as well as to brown bears; other researchers considered it to be a cave bear (García 2003, Grandal-d'Anglade and López-González 2004, Wagner 2010, Wagner and Čermák 2012).

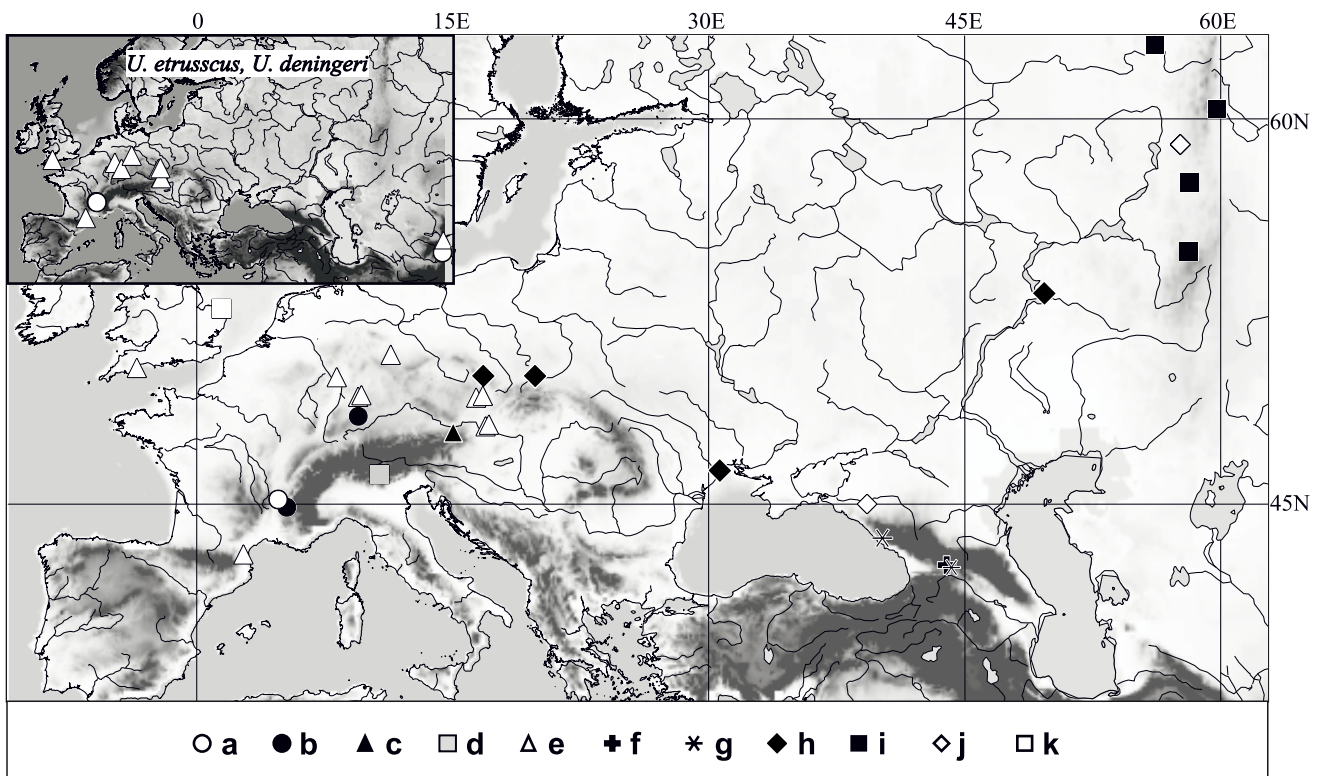

**Text-fig. 2.** Map of cave bear samples used in this work. a – *U. etruscus*, b – *U. s. spelaeus*, c – *U. s. eremus*, d – *U. s. ladinicus*, e – *U. deningeri*, f – *U. k. praekudarensis*, g – *U. k. kudarensis*, h – *U. k. ingressus*, i – *U. k. kanivetz*, j – *U. rossicus*, k – *U. savini*.

An important purpose of studies of cave bears seems to be the characterization of their morphological diversity. Such studies can reveal principal modes of adaptive evolution, and help to define the morphological space of the group, which can then be compared with those of other mammal taxa.

Earlier analyses deal with craniometrical variability of cave bears (Baryshnikov and Puzachenko 2011), and variations of their tooth morphology (e.g., Rabeder 1999, Baryshnikov 2006, Rabeder et al. 2008, Wagner and Čermák 2012). The present study is based on the morphometrical analysis of metacarpals and metatarsals. These solid bones are found intact in cave bear localities, and are abundantly represented in fossil collections. It was found that metapodial bones have sexual dimorphism in size (Toškan 2006) and modifications over time (Withalm 2001, Athen 2006); these bones also revealed difference in sites located at different elevations (Rabeder et al. 2008). There were attempts to associate data of biometric analyses of metapodial bones with genetic results (Münzel and Athen 2009, Santi and Rossi 2014). However, these studies were based on geographically restricted material. We endeavored to morphometrically analyze metacarpals and metatarsals of cave bears, using samples from geographically distanced regions and various genetic groups.

## Materials and methods

The study was based on 1,451 metacarpals and 1,513 metatarsals (Tab. 1). Their abbreviations are as follows: mtc I, mtc II, mtc III, mtc IV, mtc V – metacarpal bones I–V; mtt I, mtt II, mtt III, mtt IV, mtt V – metatarsal bones I–V.

We used representative samples from 19 localities, and 9 localities had single specimens, embracing the following taxa (Text-fig. 2): *U. deningeri* (Mosbach 2, Jagsthausen, Einhornhöhle (EINH) and Stübenborn (SUS) in Germany; Hundsheim and Deutsch-Altenburg (DA49, DA4B, DA1) in Austria; Kent's or Kents cavern (KEN) in United Kingdom; Caune de l'Arago (AR) in France; Holštejn (HOL) and Lažánky near Tišnov (LAZ) in the Czech Republic); *U. deningeri batyrovi* (Sel'-Ungur cave (SU) in Kyrgyzstan), *U. spelaeus spelaeus* (Sibyllenhöhle in Germany and Grotte du Renne at Arcy-sur-Cure (ARC) in France), *U. s. eremus* (Schwabenreith Cave in Austria), *U. s. ladanicus* (Conturines Cave in Italy), *U. k. ingressus* (Niedźwiedzia Cave and Wierzchowska Cave in Poland; Odessa (Nerubajskoe (= Nerobayskoe) and Karantinnaya Balka caves) in Ukraine; Shiriaevo 1 in Russia), *U. k. kanivetz* (Secrets Cave, Bol'shoy Glukhoy Grotto and Medvezhiya Cave in Russia), *U. rossicus rossicus* (Krasnodar in Russia), *U. r. uralensis* (Kizel Cave in Russia) and *U. kudarensis* (Akhstyrskaya Cave in Russia and Kudaro 1 and Kudaro 3 caves in Georgia). In addition, the analysis has been supplemented with several specimens from other localities, including rare bones of *U. savini* from Bacton (BACT) in England. For the comparison, the bone collection (fossils bones from Kent's Cavern and Tornewton in England, Monte Cucco in Italy, Caune de l'Arago in France, Kudaro 3 in Georgia, Bol'shoy Glukhoy Grotto (GLU), Nizhneudinskaya Cave in Siberia and Geographical Society Cave in Russian Far East, Bol'shaya Vorontsovskaya (VOR), Caucasus; recent bones from Leningrad Oblast' and Kostroma Oblast', Bashkiria Republic, Caucasus, Transbaikalia region,

Amur River basin, Kamchatka Peninsula in Russia, and Tibet region) of *U. arctos* LINNAEUS, 1758 (n = 139), and scarce findings of *U. etruscus* G. CUVIER, 1823 (Saint Vallier (SV), France and Kuruksay (KUR) in Tajikistan), which is regarded as the probable ancestor of cave bears and brown bears (Kurtén 1968), were employed.

The authors have examined the collections of the Zoological Institute of the Russian Academy of Sciences (ZIN) (Saint Petersburg, Russia), Borissiak Paleontological Institute of the Russian Academy of Sciences (Moscow, Russia), National Museum of Natural History at the National Academy of Sciences of Ukraine (Kiev, Ukraine), Samarkand University (Samarkand, Uzbekistan), Finnish Museum of Natural History (Helsinki, Finland), Natural History Museum (London, UK), Staatliches Museum für Naturkunde (Stuttgart, Germany), Niedersächsisches Landesmuseum Hannover (Hannover, Germany), Muséum National d'Histoire Naturelle (Paris, France), Musée des Confluences (Lyon, France), Institut für Paläontologie, Universität Wien (Vienna, Austria), Naturhistorisches Museum Wien (Vienna, Austria), Moravian Museum (Brno, the Czech Republic), Institute of Systematics and Evolution of Animals PAS (Krakow, Poland), Instituto di Geologia e Paleontologia, Università La Sapienza (Roma, Italy).

A scheme of measurements was used that had been elaborated for measuring of ursid bones (Tsoukala and Grandal-d'Anglade 2002). Abbreviations: GL – greatest length, Bp – breadth of the proximal end, Dp – depth of the proximal end, SD – smallest breadth in medial part of the diaphysis, Bd – depth of the distal end, Dd – depth of the distal end. Index of plumpness:  $ip = (Bd/GL) * 100$  (Withalm 2001). Measurements were provided only for specimens of adult animals with fused epiphyses. Six measurements were made using a digital sliding calliper to the nearest 0.1 mm (Text-fig. 3).

For damaged fossil bones with incomplete sets of measurements, we used the expectation-maximization (EM) algorithm (Dempster et al. 1977) to estimate the missing values. Missing data were estimated for males

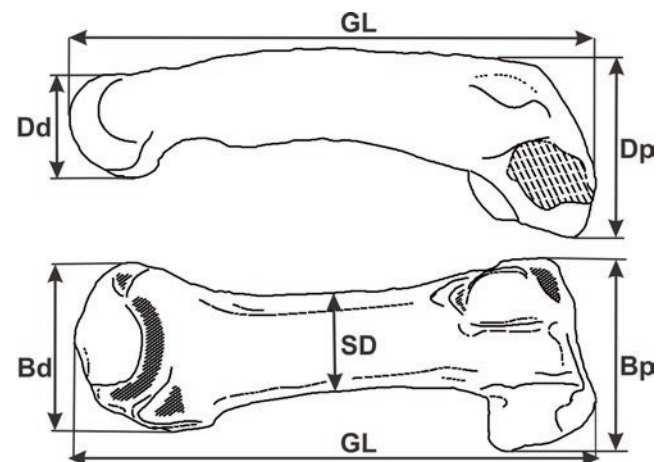

**Text-fig. 3.** Scheme of metapodial bones (mtt V) measurements in cave bears. Abbreviations: GL – greatest length, Bp – breadth of proximal end, Dp – depth of proximal end, SD – smallest breadth in medial part of diaphysis, Bd – depth of distal end, Dd – depth of distal end. Index of plumpness:  $ip = (Bd/GL) * 100$  (Withalm 2001).

**Table 1. Cave bears (according to a priori taxonomy), Etruscan bear and brown bear samples of metacarpals (mtc I–V) and metatarsals (mtt I–V) in males (M) and females (F). Partition into males and females based on results of dichotomous classification.**

Species	Subspecies or samples	Sample size, N										Total
		mtc I		mtc II		mtc III		mtc IV		mtc V		
		M	F	M	F	M	F	M	F	M	F	
<i>U. spelaeus</i>	<i>U. s. spelaeus</i>	3	4	6	10	4	10	6	22	6	5	76
	<i>U. s. eremus</i>	10	10	4	16	10	10	9	11	5	15	100
	<i>U. s. ladinicus</i>	3	7	5	9	2	11	5	5	3	3	53
<i>U. kanivetz</i>	<i>U. k. ingressus</i>	27	28	23	31	26	28	14	33	36	21	267
	<i>U. k. kanivetz</i>	10	14	6	16	3	14	5	13	8	14	103
<i>U. rossicus</i>	<i>U. r. rossicus</i>	–	–	–	–	–	1	–	–	1	–	2
	<i>U. r. uralensis</i>	3	8	8	13	4	14	11	15	7	10	93
<i>U. savini</i>		1	–	–	–	–	–	–	–	–	–	1
<i>U. kudarensis</i>	<i>U. k. kudarensis</i>	50	15	44	32	54	22	34	20	60	19	350
	<i>U. k. praekudarensis</i>	10	5	8	6	6	6	3	5	7	2	58
<i>U. deningeri</i>		16	32	18	24	14	23	13	24	19	21	203
<i>U. etruscus</i>		–	1	–	–	1	–	–	–	3	–	5
<i>U. arctos</i>	fossil	6	5	6	5	3	12	4	8	10	6	65
	recent	5	10	4	11	4	10	6	9	6	9	74
<b>Total</b>		145	138	131	175	130	161	110	165	171	125	1,451
		mtt I		mtt II		mtt III		mtt IV		mtt V		
		M	F	M	F	M	F	M	F	M	F	
<i>U. spelaeus</i>	<i>U. s. spelaeus</i>	4	8	8	10	6	12	6	12	6	5	77
	<i>U. s. eremus</i>	10	10	7	13	8	12	7	13	10	10	100
	<i>U. s. ladinicus</i>	–	–	5	6	6	8	3	9	4	4	45
<i>U. kanivetz</i>	<i>U. k. ingressus</i>	17	21	13	26	23	32	17	38	19	18	224
	<i>U. k. kanivetz</i>	6	7	6	13	10	14	5	17	12	24	114
<i>U. rossicus</i>	<i>U. r. rossicus</i>	–	1	–	–	2	–	1	–	1	–	5
	<i>U. r. uralensis</i>	5	8	12	5	10	6	17	10	12	6	91
<i>U. savini</i>		–	–	–	–	–	–	–	–	1	–	1
<i>U. kudarensis</i>	<i>U. k. kudarensis</i>	50	53	53	35	38	38	57	40	37	23	424
	<i>U. k. praekudarensis</i>	23	6	24	8	19	6	11	8	16	6	127
<i>U. deningeri</i>		18	12	29	6	17	21	15	23	10	25	176
<i>U. etruscus</i>		–	–	–	1	–	1	1	1	–	1	5
<i>U. arctos</i>	fossil	5	5	7	1	3	13	3	5	3	5	50
	recent	6	8	6	9	6	9	7	8	7	8	74
<b>Total</b>		144	139	170	133	149	171	150	184	138	135	1,513

and females separately, except for very small samples of *U. savini* and *U. etruscus*, which were consolidated with *U. rossicus* on general size of the bones. In all cases, the missing completely at random hypothesis was accepted (Pigott 2001). EM estimates the means, covariance matrix, and correlation of measures with missing values, using an iterative process. The Grubbs two-sided test (Stefansky 1972) for revealing outliers in new variables was used. Statistical differences between measurements (average, variance, type of distribution) were tested by comparing the data set, including missing values filled in by the EM method, to the initial data set. No statistical differences were detected between the two data sets. We used estimated values for multivariate analysis only.

A high degree of sexual size dimorphism (SSD) in skulls was observed for cave bears (Kurtén 1955, Grandal-d'Anglade 2001, Toškan 2006, Baryshnikov 2007, Baryshnikov and Puzachenko 2011); SSD are not identical in different taxa. Preliminary assessment of fossil bones belonging to one of the sexes were performed on canine sizes of cave bears from the caves Kudaro 1, Kudaro 3, Akhstyrskaya (*U. k. kudarensis* and *U. k. praekudarensis*), and for recent brown bear bones, according to museum labels. Metapodial bones from these samples were classified using dichotomous classification (Puzachenko et al. 2004). The results of partition of metacarpals in the Kudaro cave bear samples were compared with a priori independent partition into males and females. In most cases, we have

**Table 2. Full content of data analysis and results.**

Theme	Samples and content	Results in:
<b>Sexual size dimorphism</b>	Males and females from all taxa together for all mtc/mtt I–V.	Section “Results – Sexual size dimorphism”; Supplement I, II
	“Species level”: average SSD indexes for measures, all metacarpals for any of nine spelaeoid bears and brown bears.	
	“Metacarpals level”: average SSD indexes for measures and all taxa for any of mtc/mtt I–V.	
	“Measures level”: SSD indexes for any of six measures, five metacarpals and ten taxa; average SSD indexes of all measures and nine spelaeoid bears and brown bears.	
<b>Univariate analysis</b>	Regression analyses, pairwise comparison of taxa using nonparametric Mann-Whitney U test.	Section “Results – Univariate analysis”; Supplement I, II
<b>Multivariate analysis</b>	Males and females; two variants: all taxa, including brown bear, and spelaeoid bears with <i>U. etruscus</i> without brown bears. Analyses provided for each mtc/mtt I–V separately.	Section “Results – Multivariate model of morphospace”; Supplement I, II
	Dissimilarity matrixes of “morphological distances” between all pairs of specimens: 1) Euclidian distances, 2) distances based on Kendall tau-b coefficients.	
	NMDS used for two variants of morphospace constructing – size diversity and shape diversity morphospaces.	
	Description of modeled morphological spaces structure: correlations between measures of mtc/mtt with dimensions of models; analyses of variance (relative variance (%)) of dimensions associated with taxonomical composition). Visualization of results used scatterplots of NMDS axes.	
	Classifications of centroids (in morphospaces) of taxa used UMPGA algorithms of cluster analysis and Sattath-Tversky (Sattath and Tversky 1977) additive tree method. Consensus trees production based on NJ trees.	
	Males only; two variants: all taxa including brown bears and spelaeoid bears, with <i>U. etruscus</i> without brown bears. Analyses provided for each of five metacarpals separately.	
	Content of analysis is the same as for both sexes	
	Females only; two variants: all taxa including brown bears, and spelaeoid bears with <i>U. etruscus</i> without brown bears. Analyses provided for any of five metacarpals separately.	
Content of analysis is the same as for both sexes.		
<b>Problematic specimens</b>	Principle scheme of identification of arctoid and spelaeoid bears using fossil metapodial bones – capabilities and limitations.	Section “Results – Problematic specimens”
<b>Discussion</b>	Sources of morphological variability and disparity (sexual size dimorphism, spatial and temporal variation); morphological differentiation of bears on metacarpal and metatarsal bones; comments on evolution of spelaeoid and arctoid bears.	Section “Discussion”

a satisfactory agreement between classifications: the proportions of individuals classified differently in cluster and discriminant analysis were 11.9% for mtc I, 11.6% for mtc II, 13.3% for mtc III, 1.8% for mtc IV, and 1.6% for mtc V. Analogous results for metatarsal bones were 10.7% for mtt I, 8.6% for mtt II, 35% for mtt III, 7.5% for mtt IV, and 5.7% for mtt V.

Using these results, we classified the metapodia samples of an unknown sex into “males” and “females” for any forms of bears separately. After that, these partitions were checked and adjusted using discriminant analysis.

As a measure of sexual size dimorphism in measurements, we chose the ratio of average difference between males and females to the sum of them:  $SSD = 100 \times (M_{\text{male}} - M_{\text{female}}) / (M_{\text{male}} + M_{\text{female}})$ , where  $M_{\text{male}}$ ,  $M_{\text{female}}$  are sample means of measurements for males or females. Average sexual size dimorphism (ASSD) was calculated as

$$ASSD = \frac{1}{6} \sum_{i=1}^6 \frac{(M_{i,male} - M_{i,female})}{(M_{i,male} + M_{i,female})} 100\%$$

where 6 is the number of the measurements. The Mann-Whitney U Test was applied to test significant differences between the males and females.

The statistical analysis was carried out with STATISTICA v. 8.0 (StatSoft, Tulsa, OK, USA), PAST v. 3.12 (Hammer et al. 2001), NCSS 2007 (Hintze 2007: NCSS. NCSS, LLC. Kaysville, Utah. www.ncss.com), DARwin (Perrier et al. 2003; Perrier and Jacquemoud-Collet 2006: DARwin software, <http://darwin.cirad.fr/>), BayesTrees V1.3 (<http://www.evolution.rdg.ac.uk/BayesTrees.html>).

The nonparametric Kruskal-Wallis test was used for comparing measurements of bones in univariate analyse.

Before the multivariate statistical analysis, all measurements were standardized to exclude the impact of the scale of different measurements according to the following transformation:

$$y_{i,st} = (y_i - y_{\min}) / (y_{\max} - y_{\min}),$$

where  $y_{i,st}$  is the standardized variable, and  $y_i$ ,  $y_{\min}$ , and  $y_{\max}$  are the observed, minimum, and maximum values of the

i-th variable, respectively. The square dissimilarity matrix contained the Euclidean distances, and the similarity matrix contained the Kendall's tau-b (corrected for ties) measure of association (Kendall 1975) among all pairs of bones. Two morphological spaces (morphospaces) were constructed using the Nonmetric Multidimensional Scaling (NMDS) technique (Davison and Jones 1983), based on two types of matrices of morphological distances (see more details of our approaches to multivariate statistical analyses in Abramov et al. 2009, Baryshnikov and Puzachenko 2011, 2012, Abramov and Puzachenko 2012). Morphospaces were used as multidimensional statistical models, which were constructed to provide a compact representation of morphological distances between bones. The Euclidean metric, as a simple geometric distance in multidimensional space, integrally describes variability of bone size. The Kendall's rank measure of association can be interpreted as a metric that, on the whole, describes variability in proportions of bones or in their shapes. NMDS provides the Euclidean space with  $d$  coordinates (NMDS axes) that holds primary information on the geometrical position of each bone in this space. The coordinates of a morphospace are orthogonal, and the distance for any pair of objects within a morphospace is monotonic, proportional (linear/nonlinear) to the initial morphological distance between bones. Dimensions of the model based on the Euclidean distances matrix were denoted as E1, E2, etc., and the dimensions based on Kendall's rank correlation matrix were denoted as K1, K2, etc. The first type of morphospace describes diversity of bones on their sizes (size morphospace), and the second one on their shapes (shape morphospace).

As a high degree of sexual dimorphism was observed, we investigated male and female samples separately. In most cases, basic results are illustrated using cave bear males, if results for males and females were similar. We studied all five metacarpals/metatarsals, but because of economy and limitations of text volume, specific results are illustrated on metacarpal/metatarsal V examples. To illustrate overall results, we will use information about full sets of metacarpal/metatarsal. All the other results are in the Supplement I and II files (Tab. 2).

## Results

### Sexual size dimorphism

#### *Metacarpal bones*

We begin the presentation of results with a description of sexual size dimorphism in bears, which is a very important factor of morphological variability of metacarpals. The averages (on six measures) of relative variance components (%) that were explained by SSD were 43 (mtc I), 26 (mtc II), 41 (mtc III), 30 (mtc IV), and 39 (mtc V).

SSD and ASSD indexes vary considerably between the bear's taxa, between different metacarpals, and from measure to measure (Tab. 3, Text-figs 4, 5, and Supplement I). Principal patterns of sexual dimorphism in cave bears and brown bears are illustrated in Text-fig. 4.

Among the cave bears, the highest level of sexual dimorphism was found in *U. k. praekudarensis* (although in this case the sample size was small,  $n = 8-15$ ), against

the background of relatively low sexual dimorphism in *U. k. kudarensis* (Text-figs 4a, 5). Three taxa (*U. rossicus*, *U. s. spelaeus*, *U. s. ladinicus*) had a low level of dimorphism, and ASSD in “*spelaeus*” and “*ladinicus*” varied around six among different metacarpal bones. All other spelaeoid bears have average values of ASSD. Sexual dimorphism in *U. deningeri* lies within the range typical for all cave bears. Sexual dimorphism of brown bear metacarpals is noticeable (Text-figs 4a, 5, Tab. 3), and is higher than in most cave bears.

Dimorphism is about the same level among different bones of cave bears (Text-fig. 4b). Mtc II of brown bears has very high ASSD index (14.5); mtc IV has lowest value among metacarpals (10.1), and ASSD of mtc I, III, V are 11.6–12 (Text-fig. 4c).

The next pattern of sexual dimorphism is associated with separate measurements. SSD in spelaeoid bears and brown bears is displayed most strongly in Dp (depth of the distal end), Bp (breadth of the proximal end), and SD (smallest breadth in medial part of the diaphysis). On average, the lowest levels of dimorphism are observed based on the greatest length and depth of the distal end of the bones (Text-fig. 4d, e). This result is due to properties of the SSD index, which is proportional to the difference between males and females in percentages, i.e., in units which are standardized on absolute values of measurements of the bones.

Lengths of metacarpals are the greatest variable, so even if higher difference between the sexes in absolute units (mm) is observed, the relative difference (in percent) between males and females will be smaller in this case than for other dimensions, all other things being equal. For example, the average difference between brown bear males and females in the length of mtc V is 14.9 mm (91.1–76.2 mm; Tab. 3), that is, equal to 16.4% of the length of mtc V in males. At the same time, this difference for the depth of the proximal end (Dp) is 8 mm (31.3–23.3 mm), equivalent to the difference between males and females of 25.6%. That is why we supplemented Tab. 3 with the information about relative variances ( $v$ , %) of measurements, which are the effects of sexual size dimorphism. These effects in cave bears for mtc V are, GL – 54.0, Bp – 55.3, Dp – 62.9, SD – 52.9, Bd – 60.5, and Dd – 51.5. The data for mtc I–IV are summarized in Table 4. On average,  $v$  is 45% – 68%. The variance associated with SSD in *U. arctos* is naturally higher – from 50.7% – 96.6% (on average 68.7% – 84.6%) (Tab. 4). Intraspecific values of  $v$  in mtc V of cave bears (Tab. 3, and Supplement I) varied considerably, from 26% to 92.6%, and in many cases were higher than those of brown bears.

The UPGMA tree (Text-fig. 5a) summarizes information of sexual size dimorphism in all metacarpal bones of the studied bears. There are two groups of bears on the magnitude scale of sexual dimorphism. The first compact cluster includes spelaeoid bears, which show the average levels of SSD and ASSD. In the second group, *U. k. praekudarensis* (ASSD varies from 7.8 to 11) and brown bears (from 10.1 to 14.5) have the highest levels of dimorphism, but they clearly differ on the patterns of dimorphism in different bones. *U. s. spelaeus* has an average SSD of mtc II – mtc V (5.9–8.2), but it is about 0 for mtc I. Thus, this very peculiar pattern leads the taxas' separate positions on the classification tree. Small cave bears have the lowest sexual dimorphism (ASSD varies from 3.3 to 4.3) among all species, and are placed separately

**Table 3. Sexual size dimorphism (SSD, ASSD) of measures (GL – Dd) of mtc V in different taxa of bears; v, % – relative variances, associated with SSD and p based on Mann-Whitney U Test. \* – insufficient data for calculation.**

	SSD						ASSD
	GL	Bp	Dp	SD	Bd	Dd	
<i>U. deningeri</i>							
<b>males</b>	84.1 ± 1.11	28.9 ± 0.47	34.5 ± 0.49	17.9 ± 0.29	28.1 ± 0.38	20.7 ± 0.35	
<b>females</b>	75.0 ± 0.86	24.6 ± 0.35	29.3 ± 0.56	15.6 ± 0.23	24.9 ± 0.33	18.5 ± 0.26	
<b>SSD</b>	5.7 ± 0.88 (p < 0.001)	8.0 ± 1.10 (p < 0.001)	8.2 ± 1.17 (p < 0.001)	6.9 ± 1.11 (p < 0.001)	6.0 ± 0.95 (p < 0.001)	5.6 ± 1.11 (p < 0.001)	6.7
<b>v, %</b>	70.8	74.8	69.7	64.8	64.9	53.9	
<i>U. rossicus</i>							
<b>males</b>	63.9 ± 1.13	22.8 ± 0.48	28.9 ± 1.05	14.8 ± 0.5	23.6 ± 0.87	16.1 ± 0.30	
<b>females</b>	59.7 ± 0.77	21.3 ± 0.26	25.7 ± 0.33	13.9 ± 0.07	21.4 ± 0.32	15.3 ± 0.33	
<b>SSD</b>	3.4 ± 1.11 (p = 0.01)	3.4 ± 1.24 (p = 0.03)	5.9 ± 2.02 (p = 0.003)	n.s.	4.9 ± 2.06 (p = 0.01)	n.s.	3.9
<b>v, %</b>	40.2	26.1	56.7	–	56.5	–	
<i>U. k. praekudarensis</i>							
<b>males</b>	90.3 ± 3.35	32.1 ± 0.9	38.6 ± 0.75	18.5 ± 0.7	29.7 ± 1.39	22.1 ± 0.96	
<b>females</b>	75.8*	24.8 ± 0.25	29.4 ± 1.05	13.9 ± 0.75	24.8*	19.0*	
<b>SSD</b>	8.7	12.8 ± 1.7 (p = 0.056)	13.5 ± 1.91 (p = 0.056)	14.2 ± 3.2 (p = 0.056)	9.0	7.5	10.9
<b>v, %*</b>	–	–	–	–	–	–	
<i>U. k. kudarensis</i>							
<b>males</b>	91.4 ± 0.44	32.8 ± 0.24	38.1 ± 0.31	19.9 ± 0.22	31.2 ± 0.28	23.3 ± 0.15	
<b>females</b>	81.2 ± 1.34	29.4 ± 1.93	32.6 ± 0.84	17.1 ± 0.5	26.3 ± 0.65	20.9 ± 0.41	
<b>SSD</b>	5.9 ± 0.82 (p < 0.001)	5.5 ± 1.55 (p < 0.001)	7.8 ± 1.27 (p < 0.001)	7.6 ± 1.48 (p < 0.001)	8.5 ± 1.24 (p < 0.001)	5.4 ± 0.99 (p < 0.001)	6.8
<b>v, %</b>	80.6	51.0	62.1	50.7	67.9	66.5	
<i>U. s. spelaeus</i>							
<b>males</b>	91.6 ± 0.67	31.8 ± 0.92	37.2 ± 1.14	21.2 ± 0.35	30.8 ± 0.44	23.4 ± 0.45	
<b>females</b>	80.4 ± 1.46	28.1 ± 0.96	31.5 ± 0.71	17.3 ± 0.40	26.2 ± 0.84	20.4 ± 0.54	
<b>SSD</b>	6.5 ± 0.93 (p = 0.008)	6.2 ± 2.22 (p = 0.04)	8.3 ± 1.96 (p = 0.01)	10.1 ± 1.39 (p = 0.01)	8.1 ± 1.67 (p = 0.01)	n.s.	7.7
<b>v, %</b>	83.9	78.9	89.7	92.6	88.3	–	
<i>U. s. ladinicus</i>							
<b>males</b>	80.5 ± 1.63	27.7 ± 0.58	34.8 ± 0.73	16.6 ± 0.24	27.1 ± 0.32	19.7 ± 0.55	
<b>females</b>	74.6 ± 1.16	26.5 ± 0.87	30.6 ± 1.03	16.1 ± 0.43	25.3 ± 1.02	19.4 ± 0.37	
<b>SSD</b>	n.s.	n.s.	n.s.	n.s.	n.s.	n.s.	3.0
<b>v, %*</b>	–	–	–	–	–	–	
<i>U. s. eremus</i>							
<b>males</b>	87.2 ± 1.60	31.0 ± 0.69	37.4 ± 0.64	18.6 ± 0.25	28.8 ± 0.33	23.9 ± 2.10	
<b>females</b>	78.4 ± 0.69	27.2 ± 0.33	31.9 ± 0.59	16.1 ± 0.27	25.5 ± 0.21	19.9 ± 0.21	
<b>SSD</b>	5.3 ± 1.05 (p = 0.002)	6.6 ± 1.32 (p = 0.001)	7.8 ± 1.25 (p = 0.001)	7.2 ± 1.07 (p = 0.002)	6.2 ± 0.73 (p = 0.001)	9.1 ± 4.84 (p = 0.008)	7.0
<b>v, %</b>	79.5	79.8	72.9	76.3	89.3	73.9	
<i>U. k. ingressus</i>							
<b>males</b>	91.9 ± 0.58	33.4 ± 0.30	39.4 ± 0.47	21 ± 0.22	31.7 ± 0.25	23.5 ± 0.13	
<b>females</b>	83.0 ± 0.33	28.4 ± 0.47	33.1 ± 0.37	17.4 ± 0.24	27.0 ± 0.35	20.5 ± 0.37	
<b>SSD</b>	5.1 ± 0.45 (p < 0.001)	8.1 ± 0.91 (p < 0.001)	8.7 ± 0.83 (p < 0.001)	9.4 ± 0.85 (p < 0.001)	8.0 ± 0.74 (p < 0.001)	6.8 ± 0.89 (p < 0.001)	7.7
<b>v, %</b>	86.2	85.9	87.3	84.7	84.0	88.8	

Table 3. continued.

	SSD						ASSD
	GL	Bp	Dp	SD	Bd	Dd	
<i>U. k. kanivetz</i>							
males	88.7 ± 1.1	32.5 ± 0.44	39.2 ± 0.98	20.2 ± 0.27	31.8 ± 0.59	22.6 ± 0.41	
females	79.2 ± 1.03	27.7 ± 0.55	31.9 ± 0.69	17.3 ± 0.31	26.6 ± 0.60	19.7 ± 0.27	
SSD	5.7 ± 0.90 (p < 0.001)	8.0 ± 1.17 (p < 0.001)	10.3 ± 1.69 (p < 0.001)	7.8 ± 1.11 (p < 0.001)	9.0 ± 1.44 (p < 0.001)	6.9 ± 1.16 (p < 0.001)	7.9
v, %	77.5	79.2	79.2	79.8	77.8	80.2	
<i>U. arctos</i>							
males	91.1 ± 2.0	26.4 ± 0.69	31.3 ± 0.95	15.9 ± 0.38	24.7 ± 0.60	19.8 ± 0.46	
females	76.2 ± 1.52	20.5 ± 0.53	23.3 ± 0.71	12.1 ± 0.27	19.9 ± 0.41	16.3 ± 0.78	
SSD	8.9 ± 1.51 (p < 0.001)	12.6 ± 1.87 (p < 0.001)	14.7 ± 2.20 (p < 0.001)	13.4 ± 1.67 (p < 0.001)	10.6 ± 1.63 (p < 0.001)	9.7 ± 2.52 (p = 0.002)	11.6
v, %	66.2	78.8	81.2	75.4	75.7	59.9	

on the tree. We can conclude that sexual dimorphism levels and dimorphism patterns in metacarpal bones of cave bears show no significant connection with evolutionary age of the taxon, taxonomy, or size of the animals.

#### Metatarsal bones

Average values of relative variance components of SSD in metatarsal bones were 34 (mtt I), 27 (mtt II), 35 (mtt III), 27 (mtt IV), and 25 (mtt V) percentages (Supplement II). The main patterns of sexual dimorphism in cave bears and brown bears are shown in Text-fig. 6.

The ASSD indexes of mtt V (Tab. 5) vary from 0.6 (sexual dimorphism is statistically doubtful or absent) in

*U. rossicus* to 7–8 in *U. deningeri*, *U. k. praekudarensis*, *U. s. eremus*, *U. k. kanivetz* and brown bear. The relatively low level of ASSD was observed in *U. k. kudarensis*, *U. s. ladinicus*, *U. k. ingressus* and *U. s. spelaeus*. On the basis of information from other metatarsal bones, *U. arctos*, *U. k. praekudarensis* and *U. s. eremus* have a high SSD index, and on average, lower index values are found in *U. rossicus* and *U. k. kudarensis* (Text-figs 4a, 5a).

Correlation coefficients calculated on ASSD of metacarpals and metatarsals for all taxa are 0.88 (by means of all bears' taxa) and 0.64 (by the means of bones of the same name), so basic patterns of sexual dimorphism in the bones of bears' manus and pes are similar. In *U. k. kudarensis*,

Table 4. Aggregated data of relative variances (v, %) associated with SSD of mtc I–V and mtt I–V bones in cave bears <sup>(a)</sup> and brown bears <sup>(b)</sup>.

Bones	Measures						Average
	GL	Bp	Dp	SD	Bd	Dd	
mtc I	68.5 <sup>(a)</sup>	75.5	62.7	69.4	70.9	63.7	68.5
	73.2 <sup>(b)</sup>	75.3	50.7	81.3	81.1	84.7	74.4
mtc II	49.5	50.7	44.2	44.1	46.1	39.5	45.7
	75.6	88.1	82.3	84.8	96.6	80.4	84.6
mtc III	68.5	66.0	66.2	67.3	72.3	60.1	66.7
	74.3	59.3	67.2	68.5	75.6	70.0	69.2
mtc IV	51.1	40.9	45.3	48.4	47.8	41.1	45.8
	54.8	66.9	75.5	69.4	71.5	74.1	68.7
mtc V	54.0	55.3	62.9	56.9	60.5	51.5	56.9
	66.2	78.8	81.2	81.2	75.4	59.9	73.8
mtt I	40.7	30.1	27.2	34.1	31.6	39.5	33.9
	46.1	73.5	48.3	61.3	64.7	71.9	61.0
mtt II	27.6	21.7	26.8	14.5	20.4	23.6	22.4
	48.4	78.1	72.4	75.2	76.1	68.1	69.7
mtt III	40.2	36.7	40.0	30.5	35.8	29.7	35.5
	52.6	53.6	59.9	48.2	58.4	63.7	56.1
mtt IV	32.7	15.6	26.6	34.4	29.2	25.5	27.3
	43.3	52.1	60.7	79.6	73.5	71.1	63.4
mtt V	33.7	42.2	25.3	35.7	13.9	8.9	26.6
	12.5	21.2	27.4	19.7	23.8	45.3	25.0



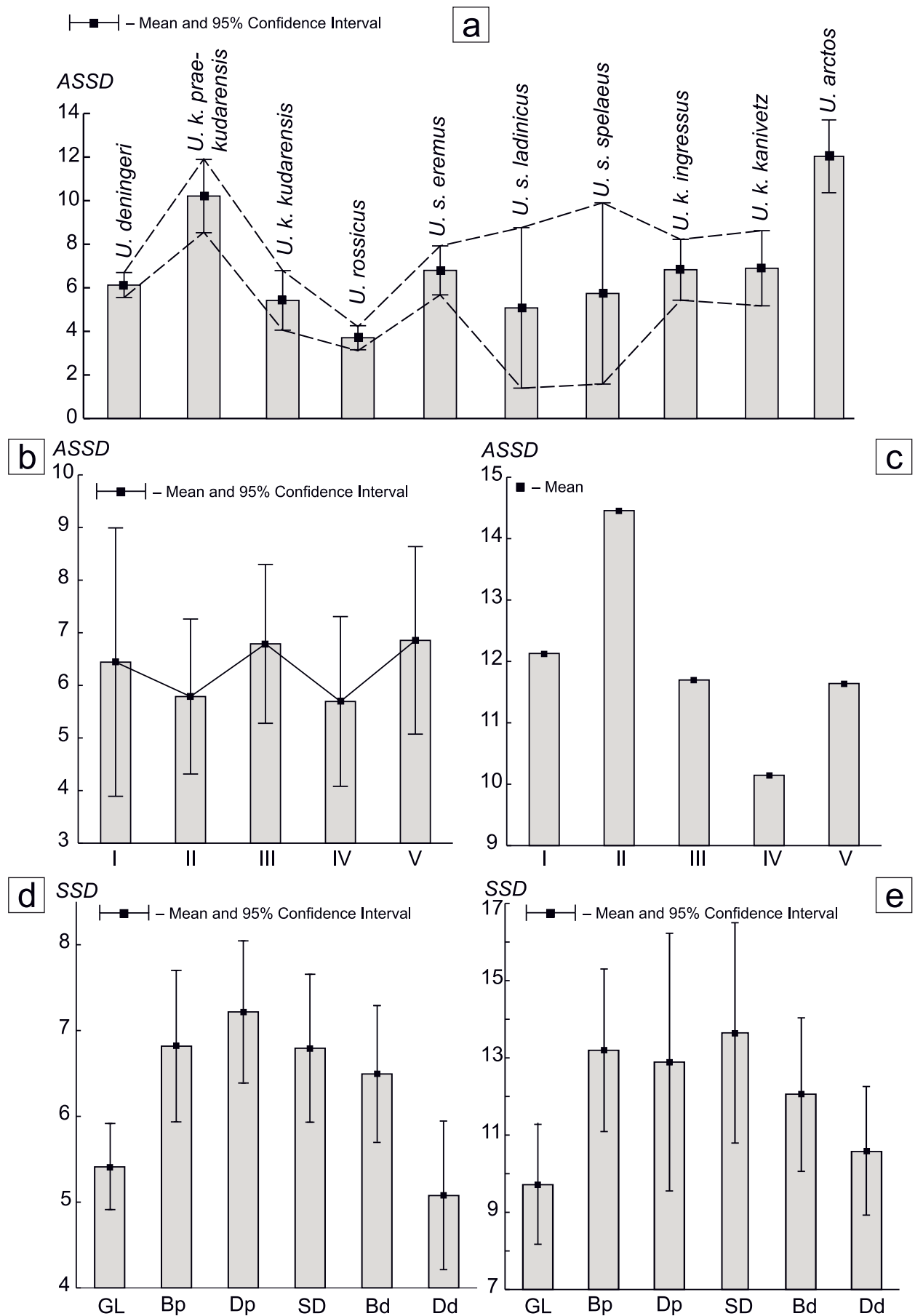

**Text-fig. 4.** Patterns of sexual size dimorphism (ASSD index) of metacarpal bones in cave bears and brown bears. a – mean values of index of six measures and five metacarpal bones; b, c – mean values of SSD index of six measures and nine cave bear taxa (b) and brown bear (c) for mtc I–V; d, e – level, mean values of index for measures (GL – Dd) in five metacarpal bones for cave bears (d) and brown bears (e).

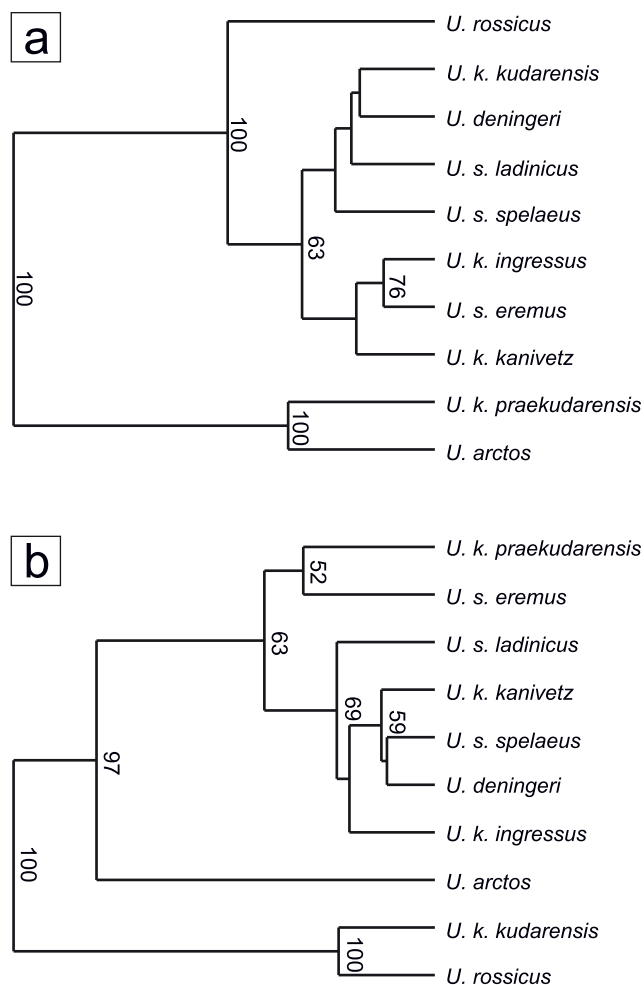

**Text-fig. 5. Classifications of taxa (UPMGA tree, Euclidian distances used) based on ASSD index of metacarpal (a) and metatarsal (b) bones. Numbers near nodes – bootstrap (1000 repeats) supports >50%.**

*U. k. praekudarensis* and *U. arctos*, sexual dimorphism of metatarsals was lower, and in all other cases there are no significant statistical differences between metacarpals and metatarsals.

Cave bears show approximately equal level of ASSD (Text-fig. 6b). In brown bears, mtt II and mtt I have maximal level of dimorphism (about 11), and in row from mtt III (10.6) to mtt V (7.5) it decreases significantly (Text-fig. 6c). On the “measures level”, patterns of sexual size dimorphism of metatarsal bones are very similar to analogous patterns of metacarpal bones in cave and brown bears, which follows from the comparison of Text-fig. 6d, e and Text-fig. 4d, e.

The SSD effects on variance in case of mtt V of cave bears are on the average (Tab. 4): GL – 33.7, Bp – 42.2, Dp – 25.3, SD – 35.7, Bd – 13.9, and Dd – 8.9. Mean relative variances of mtt I–V are 22.4% – 35.5%. Compared with metacarpals, sexual dimorphism plays a relatively low role as component of morphological variation of metatarsals on an interspecific level. On the intraspecific level, relative variances, associated with SSD, are significantly higher, especially in *U. kanivetz* (Tab. 5 and Supplement II).

In *U. arctos*, SSD relative variance for mtt V varies from 12.5% (GL) to 45.3% (Dd) (Tab. 4), and on average

for metatarsals, from 25.0% (mtt V) to 69.7% (mtt II). In this species, bones of manus and pes show a relatively more important contribution of sexual size dimorphism in their morphological variability.

The UPGMA tree (Text-fig. 5b) summarizes information of sexual size dimorphism in all metatarsal bones, and illuminates the specific pattern of SSD in comparison with metacarpal bones. One cluster includes taxa that show an average level of SSD (*U. deningeri*, *U. spelaeus*, *U. k. kanivetz*, *U. k. ingressus*). *U. s. ladinicus* is placed close to them, with relatively low indexes. *U. s. eremus* and *U. k. praekudarensis*, with the highest SSD, form a separate cluster within spelaeoid bears. The second group contains *U. kudarensis* and *U. rossicus*, which have the lowest levels of SSD. *U. arctos* has a relatively high SSD, with a very specific pattern, and so is placed separately from all cave bears. Although significant differences between the trees in Text-fig. 5 were observed, the main conclusion about lack of a phylogenetic signal in patterns of sexual size dimorphism within cave bears is confirmed.

## Univariate analysis

### Metacarpal bones

All measures of fossil bones are well correlated with each other in males and females. The main pattern of correlation size parameters of mtc V is illustrated in Text-fig. 7a–c. The points (mean values of measurements for males and females) of spelaeoid bears lie along regression lines of the scatterplots. The points of males and females of *U. rossicus* are placed near regression lines, but out of range ellipses of the spelaeoid bears. Thus, mtc V of small cave bears may be included in a common cave bear pattern of size variability, but at the same time, variation in several measures (SD, Dp) has some deviation from the general regression lines. Based on the single bone of *U. savini*, this cave bear is close to *U. rossicus* in size. However, it should be noted that measurements that characterized the thickness of mtc I of Savin’s bear are close to the low limits of these measures in the main group of cave bears.

On scatterplots (Text-fig. 7), the points of *U. etruscus* are near the points of brown bears (*U. arctos*), and so most likely, parameters of shape of metacarpals in early Etruscan bears are similar to those of brown bears, so both these species are morphologically separated from the cave bear cluster by both size and shape of bones (see Supplement I).

The relationships (correlation pattern) between different measures of mtc V in the studied taxa are illustrated by dendrograms (Text-fig. 8a), which are very similar in males and females.

Morphological differentiation among the taxa is based on measurements of mtc V estimated by Kruskal-Wallis test  $z'$  values (Tab. 6). According to the results of preliminary analysis described above, *U. rossicus* and *U. arctos* differ most from other bears. Kudaro cave bear females differ from *U. deningeri* by GL, Bp, and Dd, and from their own males, by the all measures of mtc V. There are no clear morphological differentiations between other studied bears in mtc V parameters.

On the Index of plumpness (ip, Text-fig. 7e, Tab. 7), the bears form two groups. The first group includes all cave bears with high values of the Index (mean – 33.8%, min –

**Table 5. Sexual size dimorphism (SSD, ASSD) of measures (GL – Dd) of mtt V in different taxa of bears; v, % – relative variances, associated with SSD and p based on Mann-Whitney U Test. \* – insufficient data for calculation.**

	SSD						ASSD
	GL	Bp	Dp	SD	Bd	Dd	
<i>U. deningeri</i>							
<b>males</b>	91.7 ± 1.66	32.0 ± 0.58	34.2 ± 1.19	15.0 ± 0.49	25.0 ± 0.63	19.1 ± 0.36	
<b>females</b>	79.9 ± 0.48	26.6 ± 0.47	28.9 ± 0.56	13.0 ± 0.19	22.1 ± 0.34	17.1 ± 0.22	
<b>SSD</b>	6.9 ± 1.01 (p < 0.001)	9.2 ± 1.28 (p < 0.001)	8.3 ± 2.09 (p < 0.001)	6.9 ± 1.87 (p < 0.001)	6.3 ± 1.53 (p < 0.001)	5.7 ± 1.18 (p < 0.001)	7.2
<b>v, %</b>	85.2	77.9	55.4	56.9	53.8	58.9	
<i>U. rossicus</i>							
<b>males</b>	66.1 ± 0.44	23.5 ± 0.37	24.9 ± 0.59	11.2 ± 0.16	18.4 ± 0.24	13.6 ± 0.17	
<b>females</b>	61.9 ± 0.55	23.3 ± 1.13	25.7 ± 1.12	11.1 ± 0.45	18.3 ± 0.24	13.6 ± 0.23	
<b>SSD</b>	3.3 ± 0.55 (p = 0.001)	n.s.	n.s.	n.s.	n.s.	n.s.	0.6
<b>v, %</b>	82.7	–	–	–	–	–	
<i>U. k. praekudarensis</i>							
<b>males</b>	94.9 ± 1.15	32.9 ± 0.4	32.1 ± 1.75	16.4 ± 0.20	26.5 ± 0.36	20.2 ± 0.48	
<b>females</b>	85.4 ± 1.19	26.6 ± 0.98	28.2 ± 0.79	15.6 ± 0.18	22.0 ± 0.81	17.5 ± 0.79	
<b>SSD</b>	5.3 ± 0.92 (p = 0.003)	10.5 ± 1.9 (p = 0.002)	6.5 ± 1.82 (p = 0.014)	9.1 ± 1.84 (p = 0.002)	9.3 ± 1.83 (p < 0.001)	7.3 ± 2.46 (p = 0.017)	8.0
<b>v, %</b>	82.7	86.1	44.4	76.4	77.1	28.8	
<i>U. k. kudarensis</i>							
<b>males</b>	95.8 ± 0.44	34.7 ± 0.36	34.9 ± 0.52	19.9 ± 0.22	26.4 ± 0.26	20.2 ± 0.21	
<b>females</b>	88.9 ± 0.58	32.1 ± 0.33	32.9 ± 0.49	17.1 ± 0.5	25.0 ± 0.41	19.6 ± 0.26	
<b>SSD</b>	3.7 ± 0.40 (p < 0.001)	3.8 ± 0.73 (p < 0.001)	3.0 ± 1.1 (p = 0.011)	2.2 ± 0.83 (p = 0.02)	2.8 ± 0.95 (p = 0.004)	1.7 ± 0.83 (p = 0.03)	2.9
<b>v, %</b>	81.9	38.1	6.4	12.6	25.0	13.4	
<i>U. s. spelaeus</i>							
<b>males</b>	95.8 ± 1.61	30.0 ± 0.91	29.8 ± 0.50	15.2 ± 0.27	25.3 ± 0.46	20.0*	
<b>females</b>	83.1 ± 1.37	27.2 ± 1.24	27.2 ± 1.24	12.8 ± 0.40	21.6 ± 0.44	18.0 ± 0.41	
<b>SSD</b>	7.1 ± 1.18 (p = 0.008)	n.s.	4.8 ± 1.38 (p = 0.02)	8.6 ± 1.73 (p = 0.008)	8.0 ± 1.36 (p = 0.008)	n.s.	6.5
<b>v, %</b>	87.5	–	54.6	33.2	73.9	–	
<i>U. s. ladinicus</i>							
<b>males</b>	81.8 ± 0.65	26.8 ± 0.90	29.4 ± 1.07	12.9 ± 0.33	22.2 ± 0.23	17.7 ± 0.41	
<b>females</b>	77.2 ± 1.09	25.0 ± 0.28	25.3 ± 0.57	12.0 ± 0.17	20.1 ± 0.36	16.9 ± 0.07	
<b>SSD</b>	2.9 ± 0.08 (p = 0.03)	n.s.	7.5 ± 2.23 (p = 0.03)	n.s.	n.s.	n.s.	4.7
<b>v, %</b>	75.5	–	79.0	–	–	–	
<i>U. s. eremus</i>							
<b>males</b>	92.1 ± 1.14	32.0 ± 0.65	34.9 ± 0.53	14.7 ± 0.35	25.3 ± 0.22	20.0 ± 0.80	
<b>females</b>	82.2 ± 1.15	27.0 ± 0.52	27.7 ± 0.44	12.5 ± 0.22	22.0 ± 0.32	17.6 ± 0.21	
<b>SSD</b>	5.6 ± 0.93 (p < 0.001)	8.3 ± 1.32 (p < 0.001)	11.5 ± 1.11 (p < 0.001)	8.2 ± 1.54 (p = 0.002)	6.9 ± 0.82 (p < 0.001)	6.3 ± 0.74 (p < 0.001)	7.8
<b>v, %</b>	78.3	77.2	91.5	73.3	87.4	87.9	
<i>U. k. ingressus</i>							
<b>males</b>	95.4 ± 0.73	32.9 ± 0.51	34.0 ± 1.17	15.0 ± 0.18	25.8 ± 0.30	21.0 ± 0.26	
<b>females</b>	86.0 ± 0.55	27.8 ± 0.60	28.3 ± 0.68	13.3 ± 0.20	22.6 ± 0.23	18.1 ± 0.13	
<b>SSD</b>	5.2 ± 0.50 (p < 0.001)	8.4 ± 1.30 (p = 0.003)	9.1 ± 2.19 (p = 0.01)	5.9 ± 0.95 (p < 0.001)	6.5 ± 0.79 (p < 0.001)	5.2 ± 0.77 (p < 0.001)	6.7
<b>v, %</b>	81.8	88.3	61.5	71.8	77.4	86.1	

Table 5. continued.

	SSD						ASSD
	GL	Bp	Dp	SD	Bd	Dd	
<i>U. k. kanivetz</i>							
<b>males</b>	89.1 ± 0.76	32.7 ± 0.39	37.4 ± 0.83	15.7 ± 0.42	30.0 ± 0.95	21.1 ± 0.83	
<b>females</b>	77.9 ± 0.94	27.0 ± 0.33	31.6 ± 0.49	12.7 ± 0.14	26.6 ± 0.43	19.3 ± 0.28	
<b>SSD</b>	6.7 ± 0.72 (p < 0.001)	9.6 ± 0.86 (p < 0.001)	8.5 ± 1.40 (p < 0.001)	10.3 ± 1.57 (p < 0.001)	6.0 ± 1.84 (p = 0.002)	4.2 ± 2.17 (p = 0.005)	7.6
<b>v, %</b>	77.0	87.6	77.4	84.7	75.4	33.9	
<i>U. arctos</i>							
<b>males</b>	92.5 ± 3.51	26.7 ± 1.25	29.1 ± 1.53	13.1 ± 0.58	21.4 ± 0.81	17.3 ± 0.62	
<b>females</b>	82.4 ± 2.80	22.6 ± 1.12	24.8 ± 1.45	11.0 ± 0.51	18.6 ± 0.63	14.8 ± 0.64	
<b>SSD</b>	5.7 ± 2.57 (p = 0.02)	8.3 ± 3.41 (p = 0.01)	n.s.	8.5 ± 3.21 (p = 0.02)	6.9 ± 2.56 (p = 0.01)	7.7 ± 2.78 (p = 0.002)	7.5
<b>v, %</b>	12.5	21.2	27.4	19.7	23.8	45.3	

max: 27.1% – 38.8%). *U. rossicus* (mean – 31.8%, min – max: 27.9% – 35.9%) and *U. savini* (31.9% and 29.8 %) also belong to this group, with high Index of plumpness (Text-fig. 7e, f, Tab. 6). It is the result of allometry, in which shortening of bone comes before its thinning in small cave bears. In other words, it is likely that the lower limit of the thickness (in absolute measuring units) of the metacarpal bones had been reached in small cave bears.

The second group includes only *U. arctos* and early *U. etruscus* with low Index (mean – 26.6%, min – max: 21.6% – 29.6%). The bones of these species are noticeably thin (“graceful”) in epiphyses and diaphysis. Thus, mtc V of Etruscan bears is differentiated from brown bears mostly in overall size.

Metacarpals of the cave bears are ranked according to their relative plumpness in the following order: mtc I ≤ mtc III ≤ mtc IV ≤ mtc II < mtc V. Among metacarpals, mtc V has the maximal relative plumpness (33.7%), and mtc I the minimal one (29.9%).

Within the group with high values of the Index, taxa may be ordered as follows, from the minimum to the maximum average plumpness (excluding sexual dimorphism effects): *U. k. praekudarensis* < *U. savini* < *U. k. ingressus* ≈ *U. s. spelaeus* ≈ *U. deningeri* < *U. s. ladinicus* ≈ *U. k. kudarensis* ≈ *U. s. eremus* < *U. rossicus* < *U. k. kanivetz*.

Variation of the Index of plumpness in metacarpals II–IV corresponds well to the variation of mtc V in Text-fig. 7e (also Supplement I), when all cave bears belong to the same group. On this background, the Index of mtc I has some peculiarities. Relative plumpness of bones in *U. rossicus* and *U. spelaeus* was more pronounced in females than in males (Text-fig. 7f), while the more typical opposite sexual correlation is observed in other species. Sexual dimorphism on Index of plumpness when mtc V in males is relatively more plump than in females was observed in *U. k. kanivetz* (Mann-Whitney U Test  $Z = 2.6$ ,  $p = 0.01$ ) and in *U. k. ingressus* ( $Z = 3.9$ ,  $p < 0.001$ ). In other cases, differences between males and females are not recognized. Sexual dimorphism was observed in all other metacarpals of *U. ingressus*, and in certain bones of *U. arctos*, *U. deningeri*, *U. k. kudarensis*, and *U. s. eremus* (Tab. 7).

### Metatarsal bones

Measurements of mtt V showed a pattern of correlation (Text-fig. 9) that was equal to the pattern described for mtc V. In addition, we note that a single mtt V of *U. etruscus* (most probably female) is near brown bears on the scatterplots. The same similarity between the two species held for most measurements of metacarpals and metatarsals. In the most cases, the points corresponding to brown bears and Etruscan bears lie approximately in line, and below the regression line of cave bears. However, metatarsals were found two deviations from this rule on the depth of the distal end and smallest breadth in medial part of the diaphysis of *U. etruscus* mtt II. It is not clear whether this is a purely random effect. The values of these parameters are close to mtc II of the cave bear regression line (i.e. the bone is relatively thickened in comparison with brown bears, taking into account the differences in bone size) (Supplement II).

Dimensions of the single metatarsal V of *U. savini* (probably male) are very close to females of *U. deningeri* and *U. spelaeus ladinicus*.

The estimations of morphological differences between taxa on the measures of mtt V are shown in Table 6. Males of *U. rossicus* differentiate well from Kudaro cave bears, from the taxon of *U. kanivetz*, *U. s. spelaeus* and from Deninger’s bears. *U. arctos* demonstrates a significant level of differentiation from *U. k. praekudarensis*, *U. k. kudarensis* and *U. kanivetz*. *U. k. kudarensis* males demonstrate statistically significant deviation from *U. kanivetz*, *U. s. ladinicus* and *U. arctos*. *U. k. kanivetz* differentiates from *U. k. ingressus* by GL and Bd (females only), *U. s. ladinicus*, and *U. s. eremus*. There are some specific aspects of morphological differentiation connected with sex. For example, *U. k. kudarensis* females differ from *U. deningeri* females by all measures, while males do not; *U. rossicus* males have more significant differences from other taxa than the females, and so on. Overall, in pairwise comparison there are 100 cases (18.5% from 540 pairs in the Tab. 8) of significant differences between taxa by measures of mtt V. Analogous value for mtc V is 104 cases (19%) (Tab. 6). Thus, both mtc V and mtt V bones show a relatively low degree of difference of the studied bears in pairwise comparisons. The

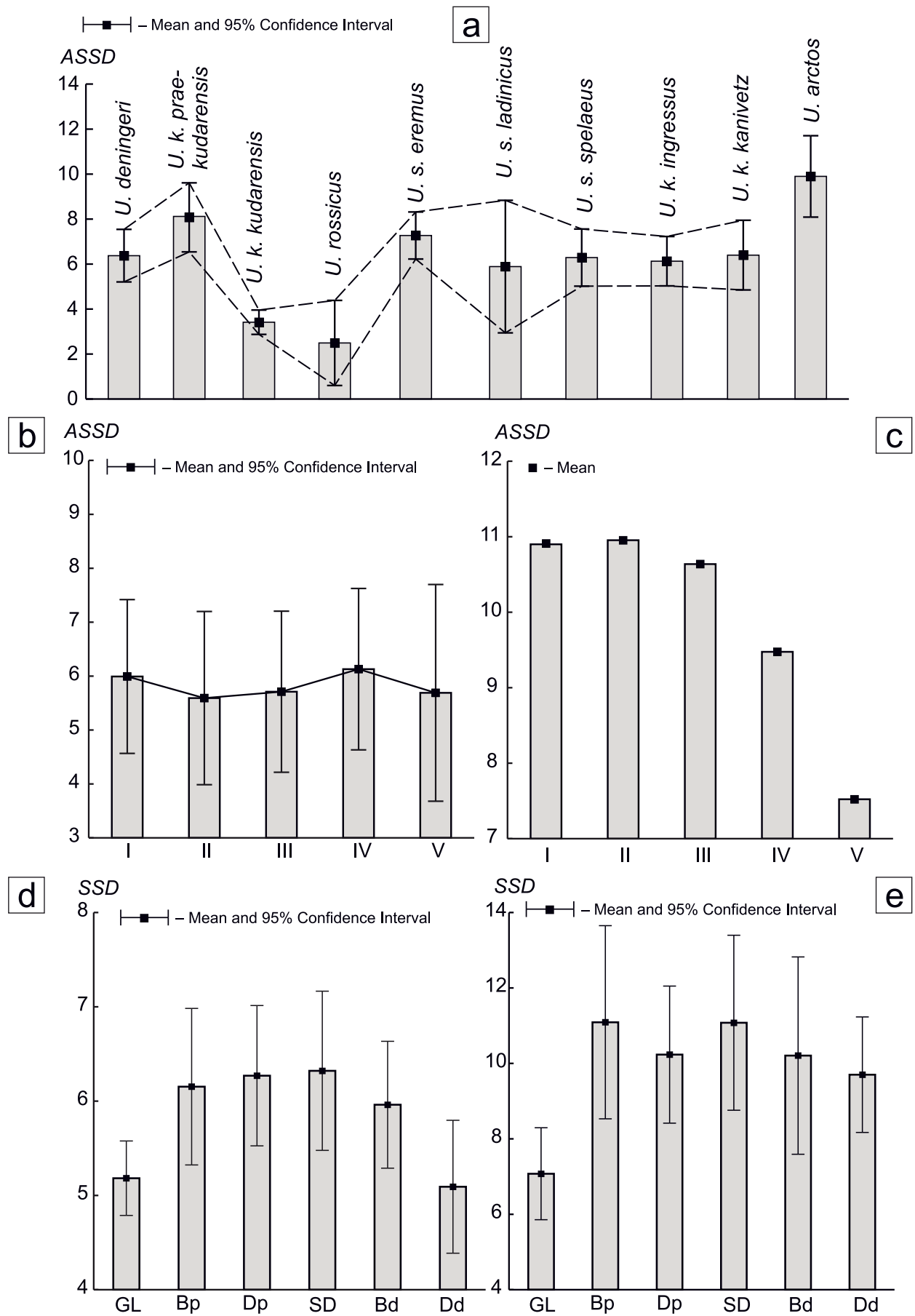

**Text-fig. 6.** Patterns of sexual size dimorphism (ASSD index) of metatarsal bones in cave bears and brown bears. a – mean values of index of six measures and five metatarsal bones; b, c – mean values of index of six measures and nine cave bear forms (b) and brown bear (c) for mtt I–V; d, e – level, mean values of index for measures (GL – Dd) in five metatarsal bones for cave bears (d) and brown bears (e).

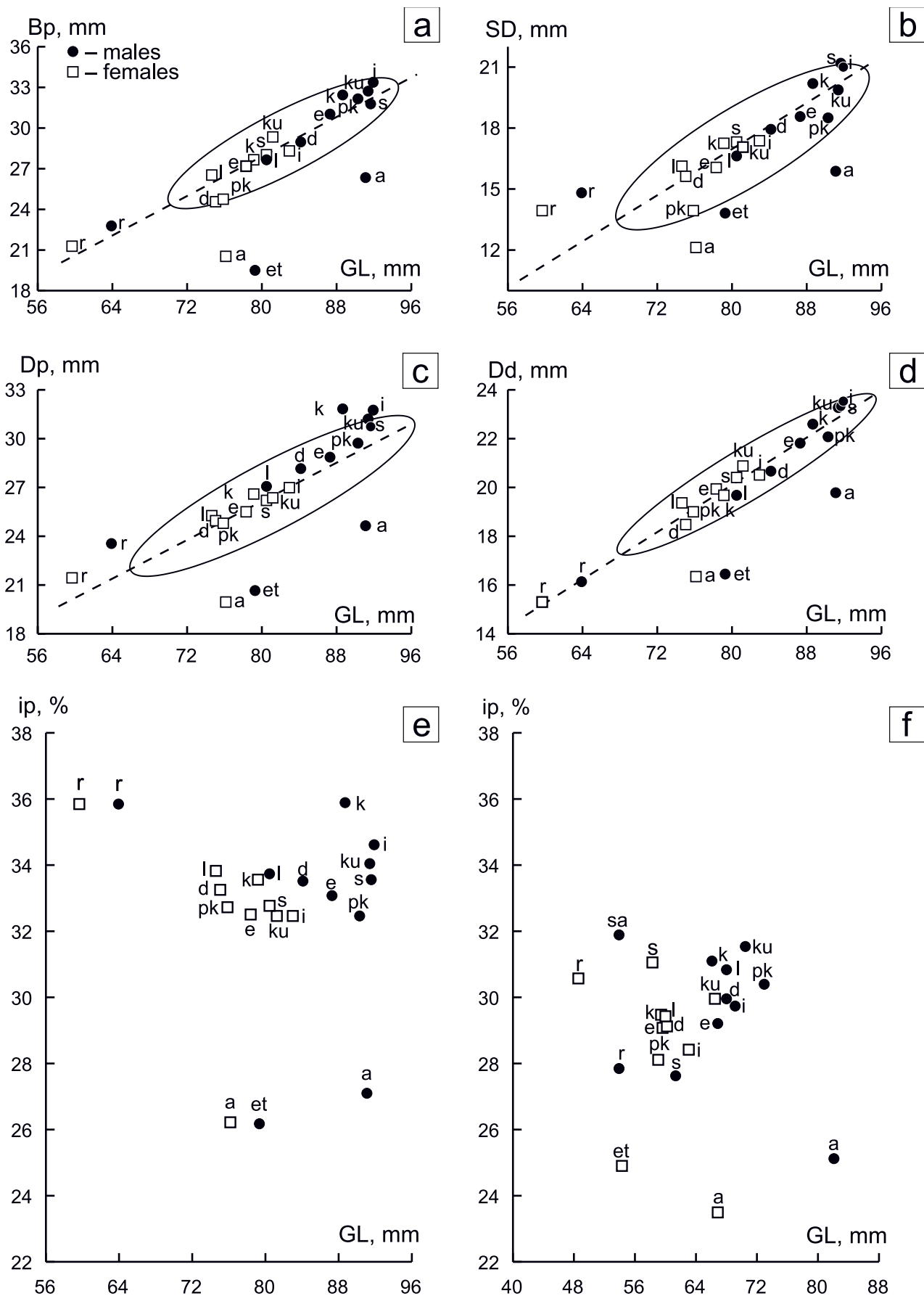

**Text-fig. 7.** a-c – scatterplots of mean length of mtc V and other measures (Bp – Dd); e, f – scatterplots of Index of plumpness (ip) and GL in mtc V (e) and mtc I (f). a – *U. arctos*, d – *U. deningeri*, e – *U. s. eremus*, et – *U. etruscus*, i – *U. k. ingressus*, k – *U. k. kanivetz*, ku – *U. k. kudarensis*, l – *U. s. ladnicus*, pk – *U. k. praekudarensis*, r – *U. rossicus*, s – *U. s. spelaeus*, and sa – *U. savini* (n = 1). Dashed lines are lines of regressions, and ellipses' horizontal and vertical projections onto axes are equal to sample mean (centroid)  $\pm$  highest value – lowest value  $\times 0.95$ .

Table 6. Mann-Whitney U test z' values (males – above and females – under diagonal) for the measures (GL – Dd) of mtc V. Statistically significant values ( $p < 0.05$ ) underlined.

Taxa	1	2	3	4	5	6	7	8	9	10	
<b>GL</b>											
<i>U. deningeri</i>	1		1.75	1.90	<u>4.65</u>	3.01	<u>4.79</u>	1.44	0.73	0.74	2.93
<i>U. rossicus</i>	2	2.35		2.84	<u>5.23</u>	<u>3.97</u>	<u>5.36</u>	2.69	1.94	0.41	<u>4.00</u>
<i>U. k. praekudarensis</i>	3	0.05	1.01		0.12	0.32	0.30	0.85	1.12	2.01	0.30
<i>U. k. kudarensis</i>	4	<u>3.32</u>	<u>4.69</u>	1.05		0.35	0.49	1.70	1.89	2.89	0.91
<i>U. s. spelaeus</i>	5	2.20	<u>3.62</u>	0.95	0.10		0.10	1.48	1.72	2.64	0.86
<i>U. k. ingressus</i>	6	<u>5.00</u>	<u>5.90</u>	1.47	1.20	0.94		1.94	2.09	3.03	1.23
<i>U. k. kanivetz</i>	7	2.26	<u>3.90</u>	0.70	0.97	0.61	2.25		0.42	1.58	0.90
<i>U. s. eremus</i>	8	1.78	<u>3.56</u>	0.53	1.46	0.95	2.82	0.48		1.13	1.22
<i>U. s. ladanicus</i>	9	0.41	1.12	0.26	2.19	1.84	2.93	1.62	1.35		2.31
<i>U. arctos</i>	10	0.68	2.74	0.17	2.47	1.68	<u>3.91</u>	1.48	1.02	0.76	
<b>Bp</b>											
<i>U. deningeri</i>	1		1.93	2.13	<u>4.69</u>	1.67	<u>4.67</u>	2.92	1.20	0.59	1.30
<i>U. rossicus</i>	2	1.99		3.26	<u>5.53</u>	2.92	<u>5.60</u>	<u>4.12</u>	2.50	0.67	0.80
<i>U. k. praekudarensis</i>	3	0.05	0.95		0.18	0.49	0.77	0.10	0.85	2.02	2.89
<i>U. k. kudarensis</i>	4	<u>3.81</u>	<u>5.08</u>	1.78		0.92	1.18	0.09	1.43	2.76	<u>5.81</u>
<i>U. s. spelaeus</i>	5	2.19	<u>3.33</u>	1.43	0.18		1.49	0.69	0.38	1.66	2.51
<i>U. k. ingressus</i>	6	<u>3.50</u>	<u>4.77</u>	1.76	0.03	0.19		0.85	1.95	3.13	<u>5.65</u>
<i>U. k. kanivetz</i>	7	2.98	<u>4.36</u>	1.45	0.63	0.24	0.61		1.11	2.37	<u>3.84</u>
<i>U. s. eremus</i>	8	2.81	<u>4.24</u>	1.33	0.93	0.42	0.89	0.27		1.33	2.05
<i>U. s. ladanicus</i>	9	1.05	2.16	0.75	1.03	0.72	1.02	0.64	0.49		0.15
<i>U. arctos</i>	10	2.62	0.30	1.14	<u>6.01</u>	<u>3.72</u>	<u>5.56</u>	<u>5.16</u>	<u>5.08</u>	2.44	
<b>Dp</b>											
<i>U. deningeri</i>	1		1.61	2.87	<u>4.29</u>	2.01	<u>4.74</u>	<u>3.58</u>	1.81	0.03	1.24
<i>U. rossicus</i>	2	2.22		<u>3.69</u>	<u>4.61</u>	2.97	<u>5.12</u>	<u>4.29</u>	2.76	1.00	0.59
<i>U. k. praekudarensis</i>	3	0.00	1.10		0.48	0.70	0.56	0.31	0.72	1.92	<u>3.65</u>
<i>U. k. kudarensis</i>	4	2.87	<u>4.53</u>	1.27		0.46	1.67	0.99	0.49	1.95	<u>5.28</u>
<i>U. s. spelaeus</i>	5	1.39	2.84	0.83	0.49		1.40	1.05	0.06	1.36	2.83
<i>U. k. ingressus</i>	6	<u>3.41</u>	<u>4.89</u>	1.67	0.86	1.08		0.23	1.37	2.59	<u>5.60</u>
<i>U. k. kanivetz</i>	7	2.23	<u>3.95</u>	1.03	0.47	0.16	1.25		1.06	2.26	<u>4.39</u>
<i>U. s. eremus</i>	8	2.60	<u>4.27</u>	1.18	0.17	0.37	0.99	0.30		1.27	2.58
<i>U. s. ladanicus</i>	9	0.52	1.79	0.35	1.00	0.51	1.47	0.72	0.90		0.66
<i>U. arctos</i>	10	2.75	0.54	1.41	<u>4.97</u>	3.23	<u>5.30</u>	<u>4.40</u>	<u>4.72</u>	2.14	
<b>SD</b>											
<i>U. deningeri</i>	1		1.94	0.77	<u>3.58</u>	<u>3.40</u>	<u>5.43</u>	2.67	0.37	0.79	1.78
<i>U. rossicus</i>	2	2.05		2.24	<u>4.69</u>	<u>4.43</u>	<u>6.04</u>	<u>3.89</u>	1.76	0.48	0.50
<i>U. k. praekudarensis</i>	3	1.14	0.04		1.52	2.34	2.91	1.52	0.26	1.21	2.08
<i>U. k. kudarensis</i>	4	2.40	<u>3.88</u>	2.18		1.63	2.78	0.46	1.64	2.43	<u>5.49</u>
<i>U. s. spelaeus</i>	5	2.13	<u>3.36</u>	2.28	0.54		0.35	1.03	2.41	3.01	<u>4.51</u>
<i>U. k. ingressus</i>	6	<u>3.38</u>	<u>4.66</u>	2.55	0.79	0.04		1.06	2.84	<u>3.38</u>	<u>7.13</u>
<i>U. k. kanivetz</i>	7	2.79	<u>4.16</u>	2.39	0.50	0.18	0.23		1.65	2.39	<u>3.99</u>
<i>U. s. eremus</i>	8	0.80	2.57	1.48	1.45	1.53	2.28	1.87		0.93	1.54
<i>U. s. ladanicus</i>	9	0.50	1.68	1.26	0.76	1.03	1.19	1.03	0.06		0.18
<i>U. arctos</i>	10	<u>3.67</u>	1.01	0.52	<u>5.71</u>	<u>4.46</u>	<u>6.75</u>	<u>5.93</u>	<u>4.14</u>	2.45	

Table 6. continued.

Taxa	1	2	3	4	5	6	7	8	9	10	
<b>Bd</b>											
<i>U. deningeri</i>	1		1.71	1.18	<u>4.36</u>	1.90	<u>4.92</u>	<u>3.27</u>	0.20	0.39	1.74
<i>U. rossicus</i>	2	2.63		2.24	<u>4.97</u>	2.98	<u>5.42</u>	<u>4.20</u>	1.44	0.70	0.30
<i>U. k. praekudarensis</i>	3	0.30	0.78		1.01	0.37	1.43	1.19	0.82	1.17	2.22
<i>U. k. kudarensis</i>	4	1.35	<u>3.46</u>	0.76		0.65	1.04	0.53	2.29	2.39	<u>6.14</u>
<i>U. s. spelaeus</i>	5	0.89	2.61	0.71	0.02		1.16	0.90	1.31	1.61	3.09
<i>U. k. ingressus</i>	6	2.78	<u>4.59</u>	1.16	1.12	0.72		0.07	2.73	2.74	<u>6.61</u>
<i>U. k. kanivetz</i>	7	1.86	<u>3.86</u>	0.92	0.43	0.27	0.68		2.24	2.40	<u>4.54</u>
<i>U. s. eremus</i>	8	0.62	2.96	0.50	0.71	0.49	1.95	1.16		0.47	1.35
<i>U. s. ladinicus</i>	9	0.07	1.73	0.31	0.67	0.58	1.35	0.94	0.26		0.55
<i>U. arctos</i>	10	<u>4.02</u>	0.46	1.01	<u>4.84</u>	<u>3.28</u>	<u>6.48</u>	<u>5.38</u>	<u>4.29</u>	2.22	
<b>Dd</b>											
<i>U. deningeri</i>	1		1.67	1.20	<u>4.84</u>	1.91	<u>5.18</u>	2.05	0.47	0.58	0.73
<i>U. rossicus</i>	2	2.18		2.24	<u>4.58</u>	2.70	<u>4.89</u>	2.98	1.64	0.65	1.12
<i>U. k. praekudarensis</i>	3	0.12	1.01		1.26	0.88	1.63	0.39	0.57	1.34	1.62
<i>U. k. kudarensis</i>	4	<u>3.86</u>	<u>4.93</u>	1.22		0.15	0.91	1.01	2.03	2.82	<u>5.16</u>
<i>U. s. spelaeus</i>	5	2.39	<u>3.60</u>	1.05	0.16		0.15	0.64	1.34	1.95	2.22
<i>U. k. ingressus</i>	6	3.21	<u>4.42</u>	1.09	0.27	0.04		1.48	2.38	3.12	<u>5.49</u>
<i>U. k. kanivetz</i>	7	2.23	<u>3.71</u>	0.64	1.52	0.90	1.13		1.03	1.84	2.51
<i>U. s. eremus</i>	8	2.82	<u>4.16</u>	0.80	1.14	0.62	0.77	0.44		0.81	0.91
<i>U. s. ladinicus</i>	9	0.86	2.14	0.35	1.34	1.01	1.12	0.40	0.67		0.17
<i>U. arctos</i>	10	1.42	0.77	0.65	<u>4.45</u>	3.11	<u>3.91</u>	3.12	<u>3.60</u>	1.64	

other metacarpal and metatarsal bones show a similar level of differences between taxa (Supplement I and II). In most cases, differences between forms of bears are not statistically significant, especially within the cave bears group.

The correlation patterns of measures of mtc V and mtt V have some differences, which have been observed in males and females synchronously (Text-fig. 8b). On this background, in all cases the lengths of bones (GL) correlated less with measurements of their thickness (Bp – Dd) than they correlated among themselves. Therefore, GL shows some independent variation from other measures. An analogous situation holds for all other metacarpals and metatarsals (Supplement I and II).

In the value of Index of plumpness (Text-fig. 9e, Tab. 7), bears form two or three groups (only for mtt V).

The first case (Text-fig. 9f) is the same as described above for metacarpals. Cave bears form a compact group, and *U. rossicus* and *U. savini* have a relatively high Index of plumpness within it (Text-fig. 9e, f). *U. arctos* and *U. etruscus* are clearly separate from the cave bears group, with low values of Index.

Metatarsal V in *U. kanivetz* has an extremely high Index (about 34%, Text-fig. 9e). It is difficult to give a reasonable explanation of this fact. We can only note that the other metatarsals of this taxon do not stand out from the same bones of other cave bears (Text-fig. 9f). In addition, we note the relatively high value of Index (28.3%) has already been mentioned above: mtt II of *U. etruscus*.

Metatarsals of cave bears are ranked according to their relative plumpness in another sequence besides metacarpals:

mtt IV ≤ mtt III ≤ mtt V < mtt II < mtt I. Metatarsal I (31.7%) and mtt II (29.9%) have maximal relative plumpness on average, and mtt IV minimal value (27.6%).

Taxa are ordered from the minimum to the maximum average plumpness as follows: *U. s. ladinicus* ≈ *U. k. ingressus* < *U. s. spelaeus* ≈ *U. deningeri* ≈ *U. s. eremus* ≈ *U. k. praekudarensis* < *U. rossicus* ≈ *U. k. kudarensis* < *U. k. kanivetz*.

Sexual dimorphism on Index of plumpness was observed in *U. rossicus*, *U. deningeri* and *U. k. kudarensis* (Tab. 7). It is possible that this form of morphological variability is also present in *U. savini*, but we have not enough data to test this hypothesis.

## Multivariate model of morphospace

### Metacarpal bones

The excellent correlation between bone measurements and data on the scatterplots in Text-figs 7 and 9 allow us to hope that the multivariate model with small dimensions will enable us to provide information about morphological variability of each bone in a compact form within morphospaces. In order to eliminate the impact of sexual dimorphism on the results, models were constructed for males and females separately.

For the joint male cave bears and brown bears, the dimensionality of the both size and shape morphospaces of mtc V were 2 (Tab. 9). This means that only two linear independent factors are responsible for the variability (formally, the variance) of all six measurements (GL



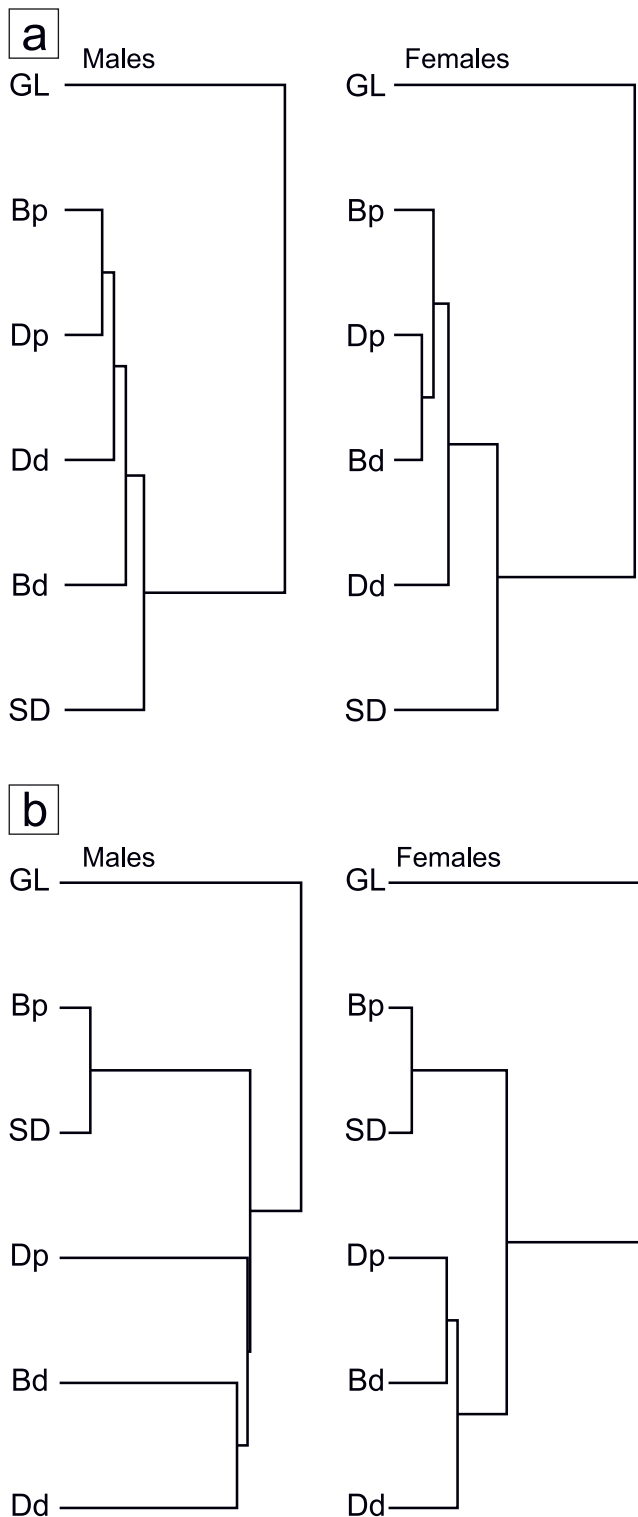

**Text-fig. 8. Relationships between measures of mtc V (a) and mtt V (b) in males and females (single linkage method, metric - Pearson correlation).**

- Dd). High coefficients of determination of the linear multiple regression models with morphospace dimensions as independent variables, and measures of metacarpal as dependent variables show that all meaningful information about variance is contained in variation of dimensions of the model.

In the size morphospace including *U. arctos*, the first dimension (E1) reflects variations of all measures to the

same extent (Tab. 9). In another words, the first dimension demonstrates high positive correlations with all of them, and describes a “general size” of the bone. The second dimension (E2) positively correlated with GL, Dd, and less with Bp. Hence, the variance of GL, Dd, and Bp includes two components that are independent of each other. Two dimensions of shape morphospace do not show correlations with measures (an exception – smallest breadth in medial part of the diaphysis, SD). The absence of correlations of K1 and K2 with measures and dimensions E1 and E2 points to isometric transformations of bone predominance, or to a low effect of allometry. The first dimension of the shape morphospace positively correlates with Index of plumpness ( $r = 0.71$ ). In addition, the Index negatively correlates with dimension E2 ( $r = -0.59$ ), which points to dependence on it from the component of variation of GL, which is independent of the bone size.

In the variant of the size morphospace without brown bears, the dimensionality collapsed to a single axis (E), which correlated well with all measures and dimension E1 from the first model ( $r = 0.99$ ). Dimensionality of the shape morphospace did not change in this case, but interpretations of K1 and K2 were a little changed; they do not show correlation with size characters of mtc V, as they did in the above-described shape morphospace. Dimension K1 correlates with E2 of size morphospace ( $r = 0.75$ ). Dimension K2 correlates at least with Dd ( $r = 0.5$ ; Tab. 9), indicating that some allometry pattern exists. K1 correlates with Index of plumpness and with the first dimension of the previous shape morphospace model. However, the correlation coefficients are not as high as we might expect. The dimension K2 correlates well with the corresponding dimension of the previous model.

In general, the presence or absence in sample specimens of brown bears does not lead to qualitative changes in the structure of multivariate models. This result reflects the existence of the general pattern of morphological variability of mtc V that is common to both brown and cave bears, which also follows from Text-figs 7 and 9.

The main effect (relative variance components in Tab. 9) of taxonomy was observed in the size morphospace (E1 (81.7%), E2 (55.5%)). The cause of this effect in the main is strong morphological differentiation between brown bears, Etruscan bears and *U. rossicus* from the group of big cave bears. Dimension K1 also contributes to morphological differentiation between these taxa, but to a lesser extent. In cases of models when *U. arctos* were absent, taxonomic differentiation was reflected in size of the bone (dimension E).

In addition, we tested the multivariate models, including eight taxa of only big cave bears (without *U. rossicus*). We wanted to find out whether there is a specific signal of morphological differentiation within cave bears, which has not been identified against the background of the powerful signal about the divergence of small and big cave bears in previous models. For males, the size morphospace has one dimension, and relative variance of the taxonomic component was 55%; i.e. it was significantly lower than in the model without *U. arctos* (Tab. 9). The shape morphospace has four dimensions, but the taxonomic components were not over 22%. The main pattern of morphological differentiation was

**Table 7. Index of plumpness (ip) of metacarpal and metatarsal bones. Statistical significant values of sexual dimorphism ( $p < 0.05$ ) according to Mann-Whitney U test underlined.**

Sex	Metacarpal bones					Metatarsal bones				
	mtc I	mtc II	mtc III	mtc IV	mtc V	mtt I	mtt II	mtt III	mtt IV	mtt V
<i>U. etruscus</i>										
males	24.9	–	–	–	26.2	–	–	23.3	22.8	–
females	–	–	24.1	–	–	–	28.3	–	23.4	23.2
<i>U. arctos</i>										
males	25.1	25.7	24.9	25.3	27.1	<u>26.4</u>	24.2	23.2	23.5	23.2
females	<u>23.5</u>	24.5	23.8	24.4	26.3	<u>23.8</u>	22.9	22.3	21.7	<u>22.7</u>
<i>U. savini</i>										
males	31.9	–	–	–	–	–	–	–	–	29.3
females	–	29.8	–	–	–	–	–	–	–	18.3
<i>U. rossicus</i>										
males	27.9	32.1	32.0	31.7	33.5	<u>33.4</u>	29.2	27.4	27.2	27.9
females	30.6	31.2	31.0	32.2	35.9	<u>31.0</u>	31.2	28.4	27.8	29.5
<i>U. deningeri</i>										
males	30.0	31.8	<u>30.6</u>	31.0	33.5	<u>32.6</u>	29.4	27.6	27.6	27.4
females	29.1	31.4	<u>29.5</u>	31.6	33.3	<u>30.4</u>	29.4	27.4	27.4	27.5
<i>U. k. praekudarensis</i>										
males	30.4	32.4	30.2	30.9	32.4	31.8	30.6	27.9	27.9	28.4
females	28.1	31.5	28.9	28.9	32.7	32.4	29.2	27.3	27.0	26.1
<i>U. k. kudarensis</i>										
males	<u>31.5</u>	32.2	30.9	31.2	34.0	<u>31.6</u>	31.1	27.7	28.2	27.6
females	<u>30.0</u>	31.8	30.0	31.1	32.5	<u>32.5</u>	31.2	28.0	28.4	28.2
<i>U. s. spelaeus</i>										
males	27.6	31.3	30.3	31.3	33.6	32.3	29.5	28.4	27.3	26.5
females	31.1	32.2	30.4	31.0	32.8	31.9	29.2	27.2	27.0	26.0
<i>U. s. eremus</i>										
males	29.2	<u>33.9</u>	31.8	<u>32.3</u>	33.1	31.8	30.5	27.8	27.9	27.5
females	29.1	<u>31.7</u>	31.1	<u>30.8</u>	32.5	30.1	29.2	27.7	27.2	26.8
<i>U. s. ladinicus</i>										
males	30.8	31.5	30.6	31.6	33.7		31.2	29.2	27.6	27.1
females	29.5	31.4	29.9	31.9	33.8		30.3	27.5	26.8	26.1
<i>U. k. kanivetz</i>										
males	31.1	33.9	30.5	32.5	<u>35.9</u>	31.6	29.8	27.6	28.6	33.7
females	29.4	33.0	30.6	32.2	<u>33.6</u>	31.6	29.7	27.9	27.5	34.1
<i>U. k. ingressus</i>										
males	<u>29.7</u>	<u>32.3</u>	<u>31.5</u>	<u>33.1</u>	<u>34.6</u>	31.5	29.9	28.6	27.8	26.9
females	28.4	<u>31.1</u>	28.8	<u>29.7</u>	<u>32.4</u>	30.5	28.4	27.2	26.8	26.3

partitioning of *U. deningeri* with *U. s. ladinicus* from the other taxa on the size of mtc V. *U. kanivetz kanivetz*, *U. k. ingressus*, *U. kudarensis kudarensis* and *U. spelaeus* took the closest positions (in decreasing order) in the morphospaces. This picture of morphological differentiation, as will be shown below, is equivalent to the ones that are reproduced in models that are more general. Therefore, it is most likely there are no additional, hidden factors of morphological differentiation in the group of large cave bears that we could have overlooked.

Graphical analysis of the models confirms that the main pattern of morphological variation of mtc V includes mainly

size variation. Variation in shape of bone, if it exists, has a subordinate role. On the scatterplot (Text-fig. 9a, b), relations between different taxa of bears are shown.

At first, along dimension E1 that positively correlates with bone size, *U. etruscus* and *U. rossicus* are partitioned from other large bears. Etruscan bears and *U. rossicus* differ by the shape of mtc V along dimension K1 (Text-fig. 10b). *U. etruscus* and small cave bears differ from each other by mtc V size along dimension E2 (Text-fig. 10a). Brown bears occupy a relatively isolated range in both morphological spaces. The metacarpals V of these species are similar in

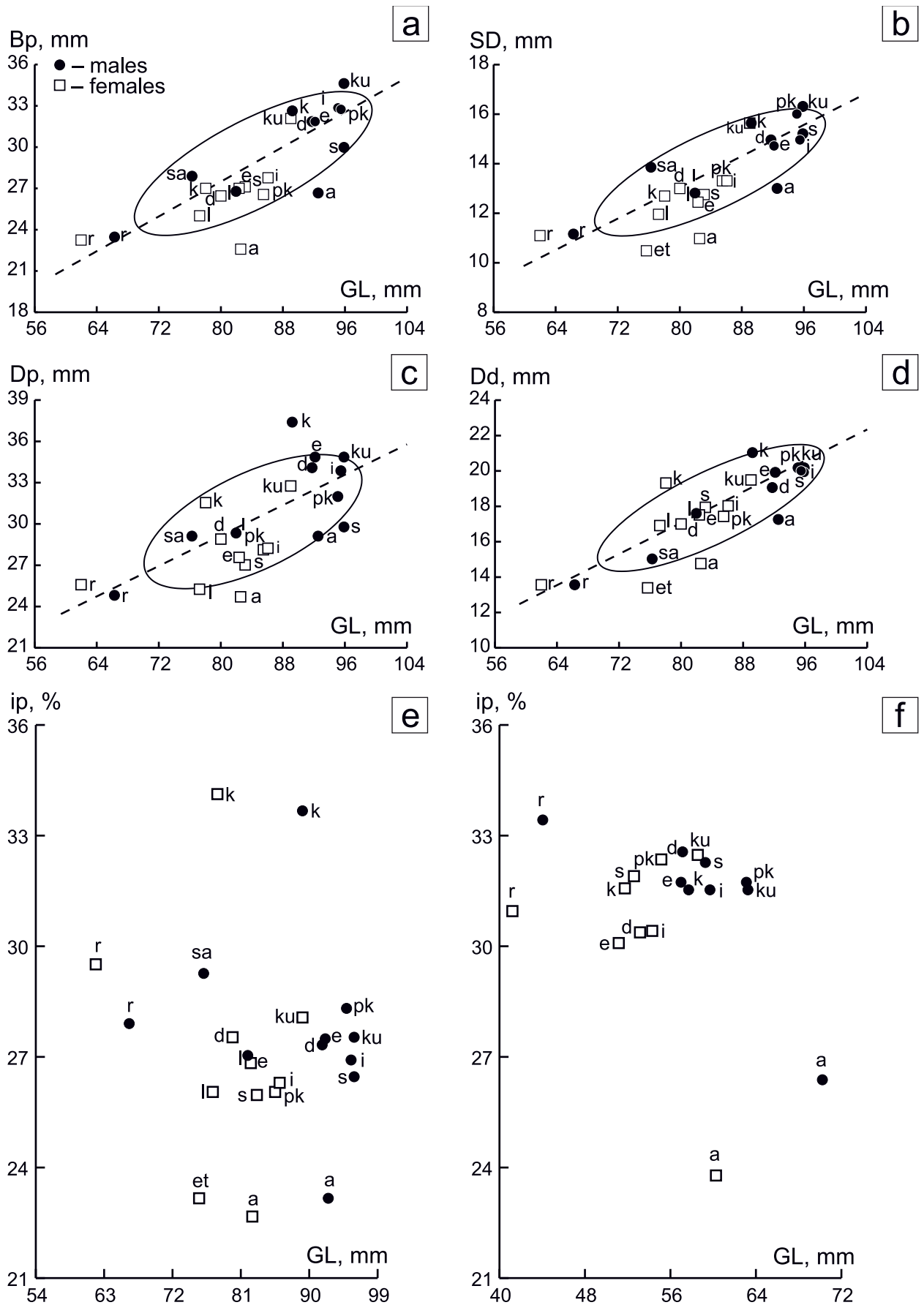

Text-fig. 9. a-c – scatterplots of mean length of mtt V and other measures (Bp – Dd); e, f – scatterplots of Index plumpness (ip) and GL in mtt V (e) and mtc I (f). a – *U. arctos*, d – *U. deningeri*, e – *U. s. eremus*, et – *U. etruscus*, i – *U. k. ingressus*, k – *U. k. kanivetz*, ku – *U. k. kudarensis*, l – *U. s. ladinicus*, pk – *U. k. praekudarensis*, r – *U. rossicus*, s – *U. s. spelaeus*, sa – *U. savini*. Dashed lines are lines of regressions, and ellipses' horizontal and vertical projections onto axes are equal to sample mean (centroid)  $\pm$  highest value – lowest value  $\times$  0.95.

Table 8. Mann-Whitney U test z' values (males – above and females – under diagonal) for the measures (GL – Dd) of mtt V. Statistically significant values ( $p < 0.05$ ) underlined.

Taxa	1	2	3	4	5	6	7	8	9	10	
<b>GL</b>											
<i>U. deningeri</i>	1		3.22	1.34	2.18	1.57	1.71	1.28	0.12	1.95	0.03
<i>U. rossicus</i>	2	2.63		4.74	6.23	4.36	5.47	2.06	3.09	0.43	3.19
<i>U. k. praekudarensis</i>	3	2.32	3.88		0.66	0.47	0.25	2.75	1.47	3.00	1.37
<i>U. k. kudarensis</i>	4	5.34	6.15	1.15		0.02	0.45	3.92	2.33	3.67	2.22
<i>U. s. spelaeus</i>	5	1.48	3.19	0.66	1.97		0.30	2.71	1.67	3.04	1.59
<i>U. k. ingressus</i>	6	4.05	5.26	0.25	1.35	1.08		3.29	1.85	3.32	1.74
<i>U. k. kanivetz</i>	7	0.75	2.16	2.78	6.06	1.93	4.79		1.15	1.06	1.25
<i>U. s. eremus</i>	8	1.36	3.33	1.15	3.03	0.39	1.92	1.95		1.86	0.09
<i>U. s. ladinicus</i>	9	1.02	1.01	2.53	4.09	1.91	3.30	0.61	1.80		1.93
<i>U. arctos</i>	10	0.80	3.01	1.65	3.91	0.86	2.73	1.45	0.56	1.45	
<b>Bp</b>											
<i>U. deningeri</i>	1		3.10	0.68	2.67	1.10	0.63	0.58	0.03	1.41	2.09
<i>U. rossicus</i>	2	1.56		3.92	6.51	1.24	3.44	3.75	3.07	0.38	0.93
<i>U. k. praekudarensis</i>	3	0.06	1.36		2.00	1.63	0.04	0.09	0.71	1.81	2.84
<i>U. k. kudarensis</i>	4	5.18	4.16	3.15		3.05	1.57	2.05	2.71	2.83	5.12
<i>U. s. spelaeus</i>	5	0.36	1.57	0.23	2.85		1.53	1.55	1.08	0.51	0.51
<i>U. k. ingressus</i>	6	1.10	2.09	0.80	2.34	0.55		0.12	0.66	1.75	2.52
<i>U. k. kanivetz</i>	7	0.65	1.90	0.34	4.75	0.04	0.69		0.61	1.75	2.70
<i>U. s. eremus</i>	8	0.65	1.85	0.40	3.52	0.13	0.50	0.14		1.40	2.06
<i>U. s. ladinicus</i>	9	1.15	0.44	0.98	4.09	1.20	1.77	1.53	1.49		0.17
<i>U. arctos</i>	10	2.62	0.01	1.85	7.14	2.13	2.94	3.27	2.82	0.57	
<b>Dp</b>											
<i>U. deningeri</i>	1		3.97	1.24	0.52	2.16	0.08	1.83	0.53	2.02	2.20
<i>U. rossicus</i>	2	1.51		2.97	5.56	1.22	3.68	5.95	4.52	0.93	1.61
<i>U. k. praekudarensis</i>	3	0.35	1.03		2.17	1.21	1.20	3.22	1.80	1.18	1.13
<i>U. k. kudarensis</i>	4	3.96	3.41	2.72		2.95	0.35	1.78	0.15	2.61	3.20
<i>U. s. spelaeus</i>	5	1.15	0.49	0.62	3.52		2.08	3.78	2.62	0.12	0.20
<i>U. k. ingressus</i>	6	0.44	1.02	0.05	2.99	0.60		1.57	0.40	1.97	2.09
<i>U. k. kanivetz</i>	7	2.91	2.90	2.08	1.09	2.88	2.31		1.29	3.42	4.03
<i>U. s. eremus</i>	8	1.01	0.83	0.38	4.09	0.34	0.35	3.27		2.42	2.72
<i>U. s. ladinicus</i>	9	2.13	0.30	1.46	4.28	0.87	1.47	3.71	1.30		0.30
<i>U. arctos</i>	10	2.38	0.02	1.37	5.35	0.66	1.39	4.57	1.21	0.36	
<b>SD</b>											
<i>U. deningeri</i>	1		3.26	1.77	2.46	0.34	0.06	0.92	0.59	1.83	1.84
<i>U. rossicus</i>	2	2.17		5.53	6.84	3.15	3.85	4.39	2.65	0.54	1.34
<i>U. k. praekudarensis</i>	3	0.36	2.11		0.53	1.12	2.04	0.84	2.43	3.22	3.82
<i>U. k. kudarensis</i>	4	4.84	4.44	2.70		1.58	3.02	1.44	3.19	3.72	4.77
<i>U. s. spelaeus</i>	5	0.46	1.51	0.64	3.29		0.33	0.44	0.85	1.96	1.94
<i>U. k. ingressus</i>	6	0.86	2.56	0.22	3.60	0.97		1.01	0.73	2.02	2.17
<i>U. k. kanivetz</i>	7	0.81	1.79	0.86	5.59	0.01	1.60		1.54	2.56	2.85
<i>U. s. eremus</i>	8	1.16	1.36	1.15	4.84	0.38	1.78	0.54		1.39	1.25
<i>U. s. ladinicus</i>	9	1.83	0.45	1.78	4.40	1.13	2.27	1.40	0.93		0.44
<i>U. arctos</i>	10	3.45	0.23	2.72	7.43	1.81	3.97	2.75	1.77	0.34	

Table 8. continued.

Taxa	1	2	3	4	5	6	7	8	9	10	
<b>Bd</b>											
<i>U. deningeri</i>	1		3.11	1.60	1.76	0.12	0.84	3.08	0.15	1.51	2.18
<i>U. rossicus</i>	2	2.62		5.01	5.74	2.79	4.47	6.49	3.26	0.53	0.83
<i>U. k. praekudarensis</i>	3	0.22	1.89		0.07	1.24	0.93	1.62	1.44	2.60	3.92
<i>U. k. kudarensis</i>	4	3.35	4.73	2.45		1.31	1.05	1.94	1.59	2.70	4.41
<i>U. s. spelaeus</i>	5	0.49	1.57	0.24	2.57		0.57	2.51	0.01	1.49	2.01
<i>U. k. ingressus</i>	6	0.79	3.04	0.72	2.42	0.96		2.65	0.68	2.12	3.32
<i>U. k. kanivetz</i>	7	5.06	5.77	3.38	1.15	3.43	3.86		2.93	3.58	5.36
<i>U. s. eremus</i>	8	0.04	2.27	0.16	2.70	0.41	0.65	3.88		1.61	2.33
<i>U. s. ladinicus</i>	9	1.53	0.57	1.12	3.39	0.87	1.93	4.20	1.37		0.02
<i>U. arctos</i>	10	3.04	0.31	1.90	5.66	1.51	3.52	7.21	2.43	0.37	
<b>Dd</b>											
<i>U. deningeri</i>	1		2.77	2.19	1.84	0.49	1.46	2.85	0.99	1.12	1.21
<i>U. rossicus</i>	2	1.67		5.31	5.31	1.65	4.55	5.69	3.78	0.94	1.37
<i>U. k. praekudarensis</i>	3	0.53	1.79		0.68	0.37	0.82	0.93	1.11	2.77	3.36
<i>U. k. kudarensis</i>	4	4.78	4.10	2.75		0.16	0.26	1.62	0.64	2.51	3.13
<i>U. s. spelaeus</i>	5	1.06	2.08	0.51	1.78		0.08	0.73	0.07	1.05	1.03
<i>U. k. ingressus</i>	6	1.94	2.62	0.81	2.56	0.12		1.67	0.37	2.24	2.67
<i>U. k. kanivetz</i>	7	5.21	4.14	2.79	0.15	1.75	2.66		1.87	3.28	3.90
<i>U. s. eremus</i>	8	0.63	1.91	0.01	3.27	0.57	0.98	3.39		1.87	2.14
<i>U. s. ladinicus</i>	9	0.38	0.97	0.67	2.85	1.05	1.37	2.85	0.71		0.15
<i>U. arctos</i>	10	1.74	0.51	1.75	5.34	2.08	3.12	5.60	1.99	0.67	

shape, naturally, but Etruscan bears are distinguished from *U. arctos* by bone size.

All the spelaeoid bears, including Deninger's bears have greatly overlapping ranges in the modeled morphospaces. *U. deningeri* and *U. s. ladinicus* are smaller than others, and are close to *U. rossicus* and *U. arctos* along dimension E1. All other cave bears form a common cloud in the morphospace. The gray ellipse on Text-fig. 10a shows the 95% range of *U. k. kudarensis* sample. This range practically overlaps all other ranges belonging to cave bears.

In the shape morphospace, Etruscan and brown bears differ from spelaeoid bears, and *U. rossicus* is clearly separated from them along dimension K1 (Text-fig. 10b). The sample range of Deninger's bears overlaps most other ranges of cave bears.

This study shows that it is impossible to divide the sample of large cave bears into species based on morphological parameters of mtc V bones only. Note that the same result follows from analysis of other metacarpal bones (Supplement I).

**Table 9. Description of modeled morphological spaces for males of cave bears and brown bears mtc V. Correlation coefficients among measures and dimensions of two morphospace models (E, E1 – E2, K1 – K2);  $r^2$  – coefficients of determination in linear multiple regression models.**

Measures	Morphospaces with <i>U. arctos</i>					Morphospaces without <i>U. arctos</i>			
	Size morphospace		Shape morphospace		$r^2$	Size morphospace	Shape morphospace		$r^2$
	E1	E2	K1	K2			E	K1	
GL	0.90	0.60	-0.34	0.15	0.86	0.92	-0.39	0.43	0.86
Bp	0.95	0.47	-0.09	0.25	0.92	0.95	-0.12	0.35	0.91
Dp	0.91	0.38	0.01	0.00	0.92	0.90	-0.15	0.10	0.87
SD	0.90	-0.03	0.28	0.45	0.96	0.88	0.24	0.35	0.92
Bd	0.96	0.25	0.09	0.29	0.95	0.95	0.05	0.30	0.94
Dd	0.96	0.51	-0.21	0.31	0.96	0.96	-0.20	0.50	0.95
ip	0.39	-0.59	0.71	0.07	0.81	0.36	0.55	-0.21	0.58
	<b>Relative variance (%) of dimensions associated with taxonomical composition</b>								
	81.7	55.5	53.9	17.8		84.8	21.3	28.7	

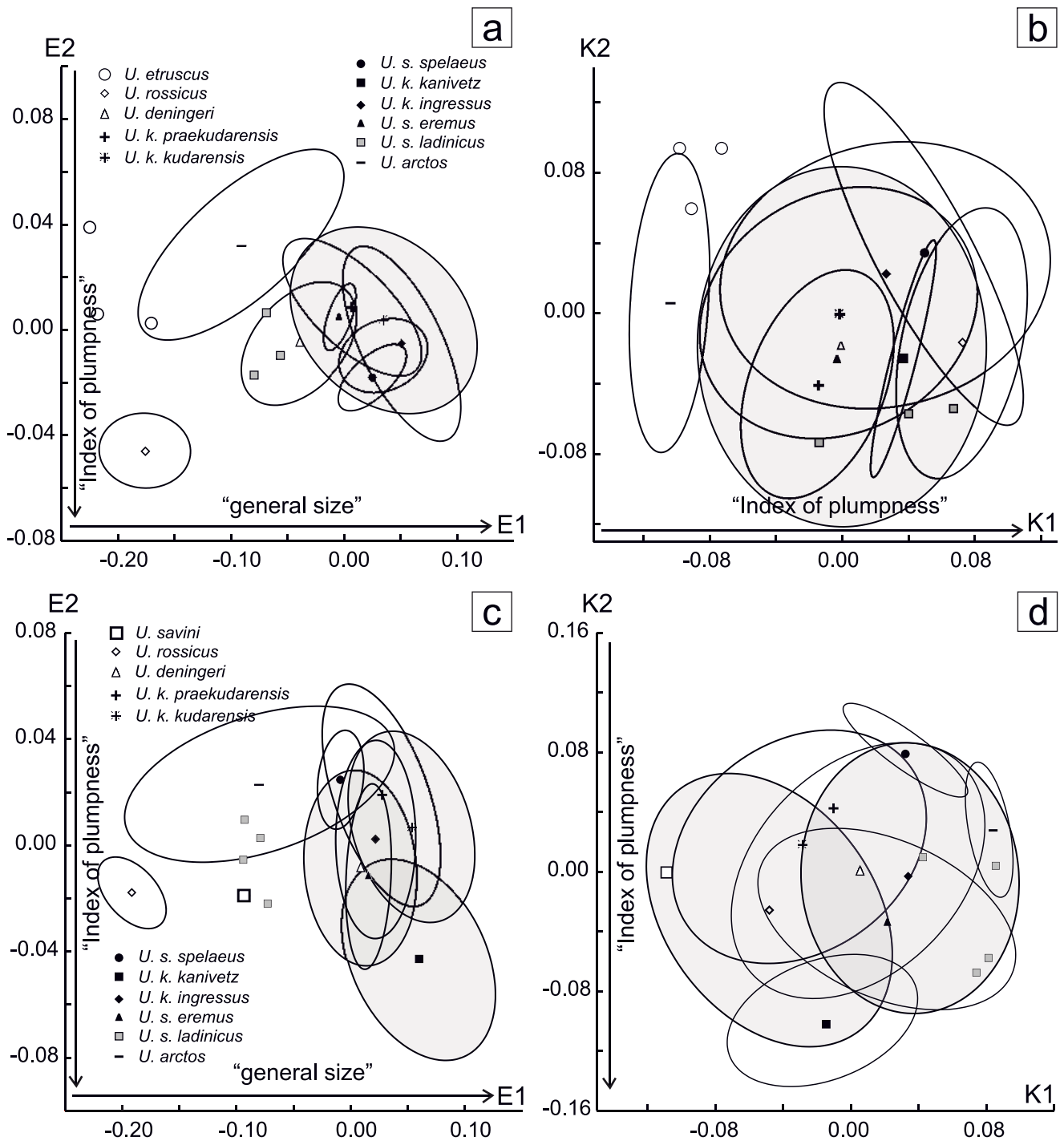

**Text-fig. 10.** Size (a, c) and shape (b, d) morphospaces reproduced variation of mtc V (a, b) and mtt V (c, d) in males (sample centroids are marked). Ellipses' horizontal and vertical projections onto axes are equal to sample mean (centroid)  $\pm$  highest value – lowest value  $\times 0.95$ . Gray ellipses belong to *U. k. kudarensis* (a), *U. deningeri* (b), *U. deningeri*, *U. k. praekudarensis*, *U. k. kanivetz* (c), and *U. rossicus*, *U. k. praekudarensis*, *U. k. ingressus* (d).

The relatively low morphological differentiation between most taxa is well illustrated by UPGMA classifications of their sample centroids in morphospaces (Text-fig. 11). Deninger's bears are placed in the cluster that includes spelaeoid bears. Metacarpal V of male cave bears from Conturines Cave (*U. s. ladinicus*) is relatively close to Deninger's bears in overall size, which is reflected in UPGMA and additive trees. The next morphologically narrow group includes four taxa of cave bears (*U. s. spelaeus*, *U. kanivetz ingressus*, *U. kanivetz kanivetz* and

*U. kudarensis kudarensis*), which belong to different genetic lineages. In all cases, the main groups or morphological clusters include unevenly-aged (evolutionarily) taxa. It is necessary to pay attention to the relatively isolated position of *U. etruscus* with *U. arctos* and special position of small cave bears (*U. rossicus*) in relation to other spelaeoid bears. The analogous classifications of centroids of female samples (Text-fig. 11) confirm a separate status of brown bears and small cave bears. At the same time, classifications of large cave

**Table 10. Dimensionalities (E, K) of modeled morphological spaces for males (m) and females (f) of cave bear and brown bear mtc I–V bones. v, % – relative variance of dimension E1 associated with taxonomical composition of samples; r<sup>2</sup> – average coefficients of determination of six measures in linear multiple regression models.**

Bone	Morphospaces with <i>U. arctos</i>								Morphospaces without <i>U. arctos</i>							
	Size morpho-space, E		Shape morpho-space, K		r <sup>2</sup>		v, %		Size morpho-space, E		Shape morpho-space, K		r <sup>2</sup>		v, %	
	m	f	m	f	m	f	m	f	m	f	m	f	m	f	m	f
mtc I	2	2	2	2	0.83	0.90	70	69	2	1	2	2	0.85	0.85	77	74
mtc II	2	2	1	2	0.88	0.94	80	85	2	1	2	2	0.91	0.91	84	86
mtc III	1	2	3	2	0.88	0.91	75	75	1	1	3	4	0.89	0.93	77	71
mtc IV	2	2	2	2	0.93	0.93	81	81	1	2	1	2	0.89	0.92	84	75
mtc V	2	2	2	2	0.93	0.92	82	77	1	2	2	2	0.91	0.88	85	68

bear females are significantly different from classification of males. Both male and female classification instability is a sign of a relatively weak morphological differentiation of taxa on the parameters of mtc V.

These results were gathered from other metacarpals (Supplement I). Dimensions of models of morphospaces for other metacarpal bones ranged generally from 1 to 2 (Tab. 10). In one case of a female's mtc III, dimension of shape morphospace reached 4. Structures of the morphological spaces are generally similar for all bones, and correspond to the size and shape morphospaces of mtc V. The taxa are most differentiated by sizes of bones, so we focus on the first dimension of size morphospaces. The relative variance of dimension E1 associated with taxonomical composition of the sample varies from 70% (male, mtc I) to 85% – 86% (female, mtc II). However, we have seen that this high percent of variance mainly reflects the morphological differentiation between the triad of *U. rossicus*, *U. arctos* and *U. deningeri* against all other cave bears.

The consensus Bayes tree on Text-fig. 12a is based on 1,000 bootstrap repeats of trees constructed for sample centroids from size and shape morphospaces of mtc I, mtc III, and mtc V belonging to males; all samples include several bones of Etruscan bears. According to this morphological classification, differentiation of Etruscan bears, small cave bears, brown bears and Deninger's bears have good statistical supports. All other taxa of spelaeoid bears are very close to each other, and their differentiations have low supports. Analogous trees constructed for centroids of all metacarpals (*U. etruscus* and *U. savini* were excluded) are shown in Text-fig. 12b–d. The trees have different topologies, except for strong supported differentiation of *U. arctos* and *U. rossicus* from large cave bears. For the sample of males, the small *U. s. ladinicus* is included in the branch with small cave bears, but in females, this taxon is placed between *U. deningeri* and medium-sized *U. s. eremus*. In addition, among females, *U. k. praekudarensis* occupies an isolated position, closer to Deninger's bears, which seems to be one of the results of strong sexual dimorphism in the first taxon.

Finally, the consensus tree in Text-fig. 12d shows the partition of male and female jointly. In this case, with high support, brown bears, small cave bears, and Deninger's bears differ. In addition to these species, *U. s. ladinicus* and

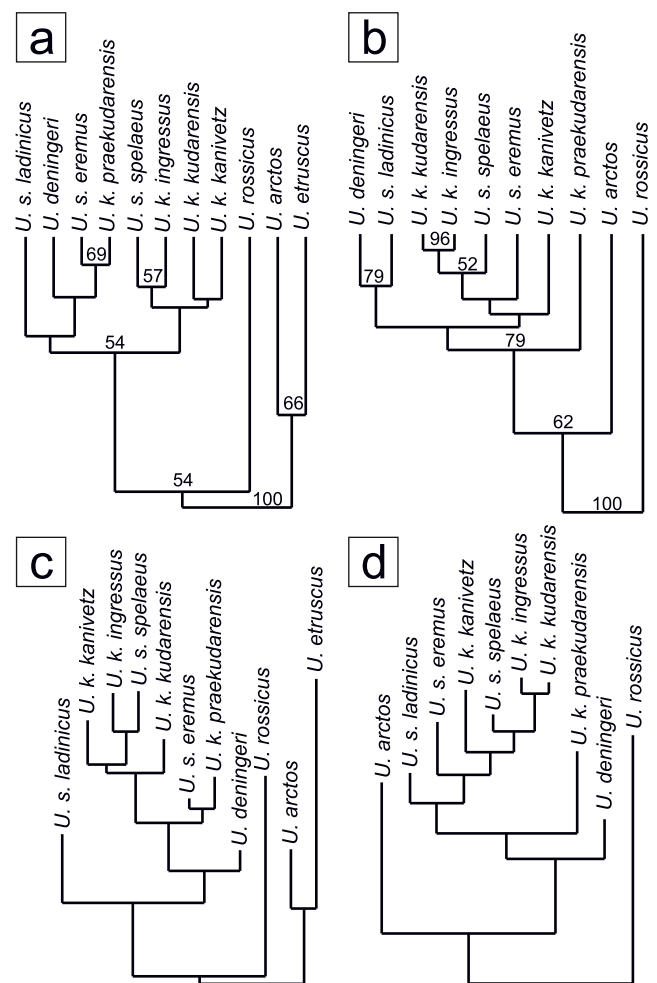

**Text-fig. 11. Classifications of centroids of bear samples in morphospaces (a, c – males, b, d – females). a, b – UPGMA dendrograms (cophenetic correlations – 0.88, 0.95); c, d – Sattath-Tversky (Sattath and Tversky 1977) additive trees. All classifications based on coordinates of joint samples of centroids of mtc V in size and shape morphospaces (Text-fig. 10); numbers near nodes – bootstrap (1000 repeats) supports >50%.**

*U. k. kanivetz* differ morphologically from other cave bears, with relatively high supports, and two subspecies of Kudaro cave bear are noticeably differentiated.

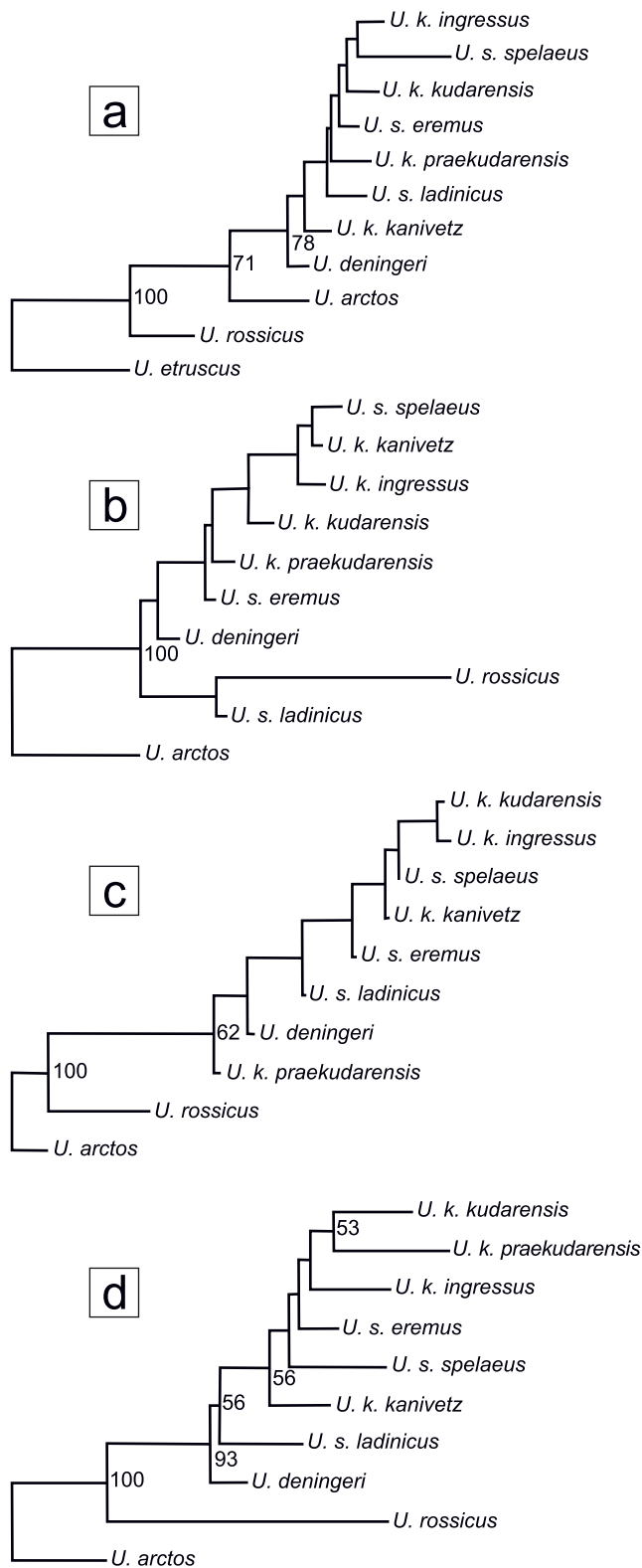

**Text-fig. 12. Consensus Bayes trees (UPGMA method, Euclidian distance) of centroids of samples in size and shape morphospaces. a – males, mtc I, III, and V; b – males, mtc I – V; c – females, mtc I – V; d – males and females, mtc I – V. Numbers near nodes – bootstrap (1000 repeats) supports >50%.**

### Metatarsal bones

For the joint male samples of cave bears and brown bears, the dimensions in both size and shape morphospaces

of metatarsal V were 2 (Tab. 11). High coefficients of determination of linear multiple regression models with morphospace dimensions as independent variables and measures of mtt V as dependent variables show that all meaningful information of bone's variation is represented in the dimensions. Measures GL and Dp have two independent components of size variability. Moreover, in this case, measurement Dp is negatively correlated with the second dimension, and Dd correlates with the first dimension only. The first dimension of shape morphospace does not show significant correlation with measures. Isometric variation is predominant in this case, too. Index of plumpness shows correlation with the second size and shape dimensions.

Relative variances associated with taxonomic composition of the samples were high for dimension E1 (83%), and noticeably low (48%–41%) for other dimensions of the models.

The second variant of models, which excludes the sample of *U. arctos*, has dimensionality 2 (size morphospace) and 3 (shape morphospace) (Tab. 11). Structure of the size morphospace is equally described above. In the shape morphospace, relatively high correlations between GL, Dd and Bp with dimensions K2 and K3 reflect some allometry contribution to mtt V variability in cave bears. The highest percentage of variance (~90%) associated with the taxonomy partition was observed in the first dimension of size morphospace. The main differences between taxa within spelaeoid bears should manifest primarily in the size of mtt V, while shape of the bone probably has more monotonic or stochastic variation.

Both models of morphospaces without *U. arctos*, *U. etruscus*, *U. rossicus*, and *U. savini* had two dimensions. Relative taxonomic variances were 54% and 50% for dimensions E1, E2, and 45% and 25% for K1, K2. It is interesting that axis E1 is not correlated with GL, and so does not represent a size variation in this case, but it correlates with other measurements of mtt V, and hence length of the bone varies independently from measures of its width (except partially depth of the proximal end, Dp). The dimension of the shape morphospace K1 well correlates with GL and Dp, and K2 with Bp and SD, which points to potential existence of two independent allometry patterns within big cave bear group. Indeed, the Index of plumpness correlates with E1 and E2 alike ( $r = 0.56-0.59$ ), but with opposite signs. The Index of plumpness also correlates with K1 ( $r = 0.6$ ), and more weakly with K2 ( $r = 0.36$ ) dimensions.

On the scatterplot illustrating the general model of size morphospace (Text-fig. 10c), *U. arctos* and small cave bears (*U. rossicus*, *U. savini* and *U. s. ladinicus*) are partitioned from the other bears along dimension E1, which positively correlates with bone size. *U. k. kanivetz* differentiates from other big cave bears along dimension E2, because the mtt V of this species is unusually plump. From that time, most big cave bears have greatly overlapping ranges in the morphospaces. In the shape morphospace, all bears form a relatively compact cloud (Text-fig. 10d). Similar results were obtained for other metatarsal bones (Supplement II).

Versions of the models that do not include *U. arctos*, *U. etruscus*, *U. rossicus* and *U. savini* show similar patterns of taxa separation in the morphospaces. Meanwhile, some specific points were observed for the shape morphospace



**Table 11.** Description of modeled morphological spaces for males of cave bears and brown bears mtt V. Correlation coefficients among measures and dimensions of two morphospace models (E1 – E2, K1 – K3);  $r^2$  – coefficients of determination in linear multiple regression models.

Measures	Morphospaces with <i>U. arctos</i>					Morphospaces without <i>U. arctos</i>					
	Size morphospace		Shape morphospace		$r^2$	Size morphospace		Shape morphospace			$r^2$
	E1	E2	K1	K2		E1	E2	K1	K2	K3	
<b>GL</b>	0.85	0.42	-0.26	0.34	0.91	0.87	0.37	0.34	0.48	0.19	0.92
<b>Bp</b>	0.93	0.19	0.15	0.12	0.89	0.93	0.11	0.26	0.21	0.42	0.94
<b>Dp</b>	0.83	-0.42	0.06	-0.43	0.92	0.81	-0.49	-0.35	0.05	0.24	0.95
<b>SD</b>	0.89	0.32	0.28	0.21	0.92	0.89	0.21	0.36	-0.02	0.10	0.93
<b>Bd</b>	0.91	-0.06	0.06	-0.12	0.84	0.91	-0.16	0.00	0.09	-0.06	0.90
<b>Dd</b>	0.91	0.07	-0.19	-0.04	0.89	0.91	-0.01	0.06	0.43	-0.01	0.92
<b>ip</b>	0.31	-0.59	0.36	-0.57	0.63	0.26	-0.66	-0.42	-0.43	-0.36	0.76
<b>Relative variance (%) of dimensions associated with taxonomical composition</b>											
	83.3	48.7	41.3	41.7		89.7	47.7	36.8	40.8	30.4	

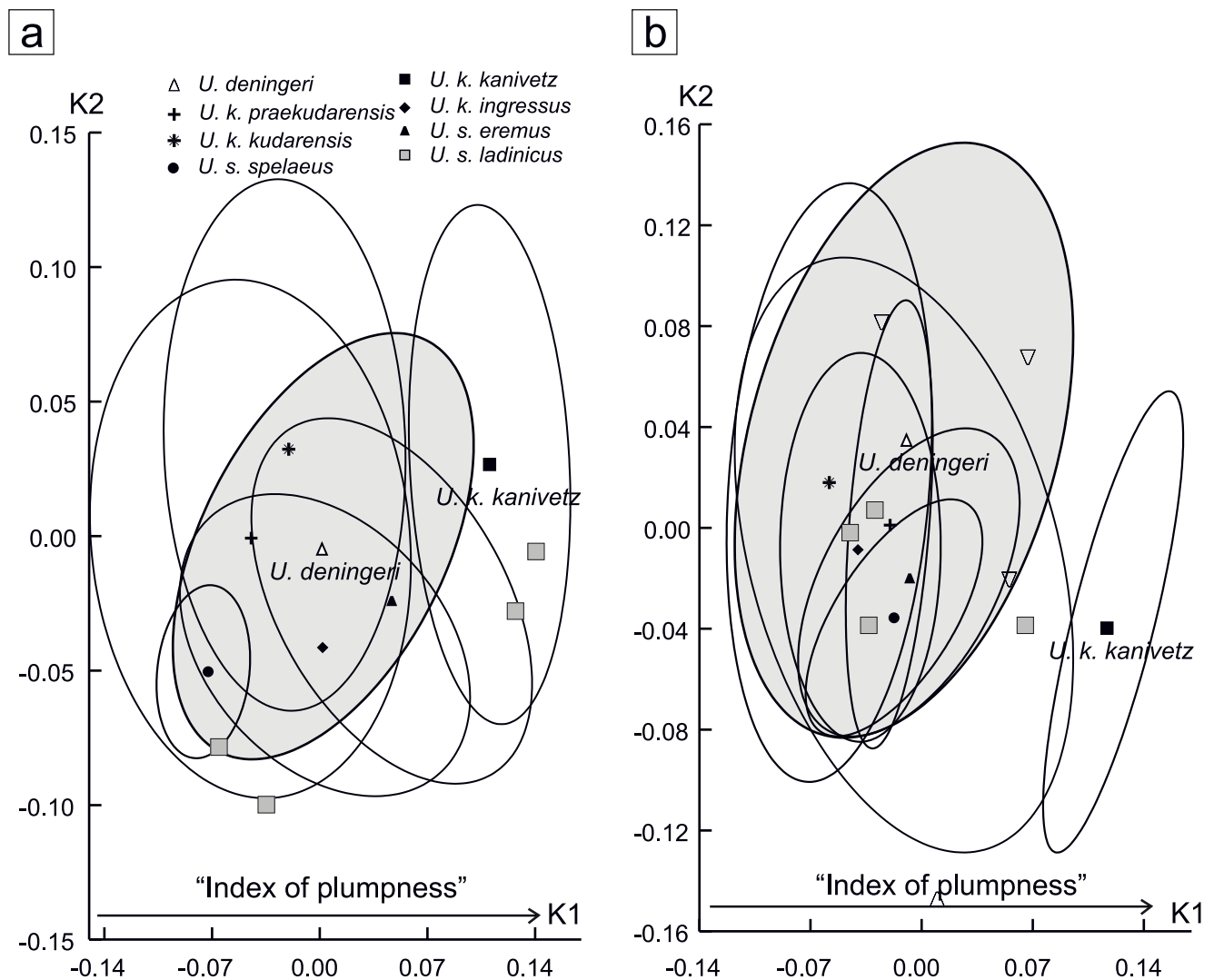

**Text-fig. 13.** Shape morphospaces reproduced variation of mtt V in males (a) and females (b) when *U. arctos*, *U. etruscus*, *U. rossicus* and *U. savini* were excluded (sample centroids are marked, except centroid of *U. s. ladanicus*). Ellipses' horizontal and vertical projections onto axes are equal to sample mean (centroid)  $\pm$  highest value – lowest value  $\times$  0.95.

**Table 12. Dimensionalities (E, K) of modeled morphological spaces for males (m) and females (f) of cave bear and brown bear mtt I–V bones. v, % – relative variance of dimension E1 associated with taxonomic composition of sample; r<sup>2</sup> – average coefficients of determination of six measures in linear multiple regression models.**

Bone	Morphospaces with <i>U. arctos</i>								Morphospaces without <i>U. arctos</i>							
	Size morpho-space, E		Shape morpho-space, K		r <sup>2</sup>		v, %		Size morpho-space, E		Shape morpho-space, K		r <sup>2</sup>		v, %	
	m	f	m	f	m	f	m	f	m	f	m	f	m	f	m	f
mtt I	2	2	2	3	0.81	0.91	73	85	2	2	3	2	0.88	0.91	83	86
mtt II	2	2	2	2	0.92	0.91	83	73	2	2	2	2	0.94	0.89	88	71
mtt III	1	1	2	2	0.88	0.87	79	81	1	2	2	2	0.88	0.89	88	76
mtt IV	1	1	2	2	0.90	0.88	89	83	1	1	2	2	0.91	0.87	92	80
mtt V	2	2	2	2	0.89	0.90	83	69	2	1	3	2	0.93	0.85	90	74

(Text-fig. 13). For both males and females of big cave bears, *U. k. kanivetz* differentiates from other taxa along dimension K1, which correlates with the Index of plumpness. Other

taxa form a more compact group in the morphospace, and all centroids fall into the range of Deninger's bears. There are no other significant hidden factors of morphological differentiation of cave bears that were not described in the general multivariate models of full sets of taxa.

The UPGMA and additive trees (Text-fig. 14) illustrated differentiation of males and females in morphospaces of mtt V. *U. etruscus*, *U. arctos* and *U. rossicus* (with *U. savini*) differentiate from other bears. Deninger's bears are members of a spelaeoid cluster. In comparison with mtc V, the classifications reflect a relatively low level of morphological differentiation within big spelaeoid bears and impacts of sexual dimorphism on the results.

Parameters of other modeled morphospaces are summarized in Tab. 12. Dimensionalities vary from 1 to 3, but in most cases they were 1 or 2. Relative variance (in percentage) of dimension E1 associated with taxonomical composition varies among models from 69 (female, mtt V, morphospace with *U. arctos*) to 92 (male, mtt IV, morphospace without *U. arctos*). The main differentiation is between *U. rossicus*, *U. arctos* and all other cave bears.

The consensus Bayes trees in Text-fig. 13 are generalizations of relations between taxa based on metatarsal bones in males and females. Etruscan bears, small cave bears (*U. rossicus*) and brown bears separate from the others. In males, brown bears combine with *U. deningeri* (Text-fig. 13a). In the final consensus tree (Text-fig. 13c), which shows the partition of male and female jointly (Etruscan bears excluded), strong morphological differentiation is supported for *U. arctos*, *U. rossicus*, *U. k. kanivetz*, *U. k. ingressus*, *U. s. ladinicus* and *U. s. eremus*.

The trees in Text-figs 11, 12, 14 and 15 most likely do not reflect the phylogenetic structure within cave bears. Sub-clusters contain various morphological forms having evidently different evolutionary history. It is enough to note here that two subspecies of Kudaro cave bears are often put in different sub-clusters, as well as *U. k. kanivetz* and *U. k. ingressus*. All classifications reflect only morphology of the bones, first, variability of their size and, second, variability in their shape.

#### Problematic specimens

We had five to ten bones that were not assigned to a particular taxon (Tab. 13). According to the results of

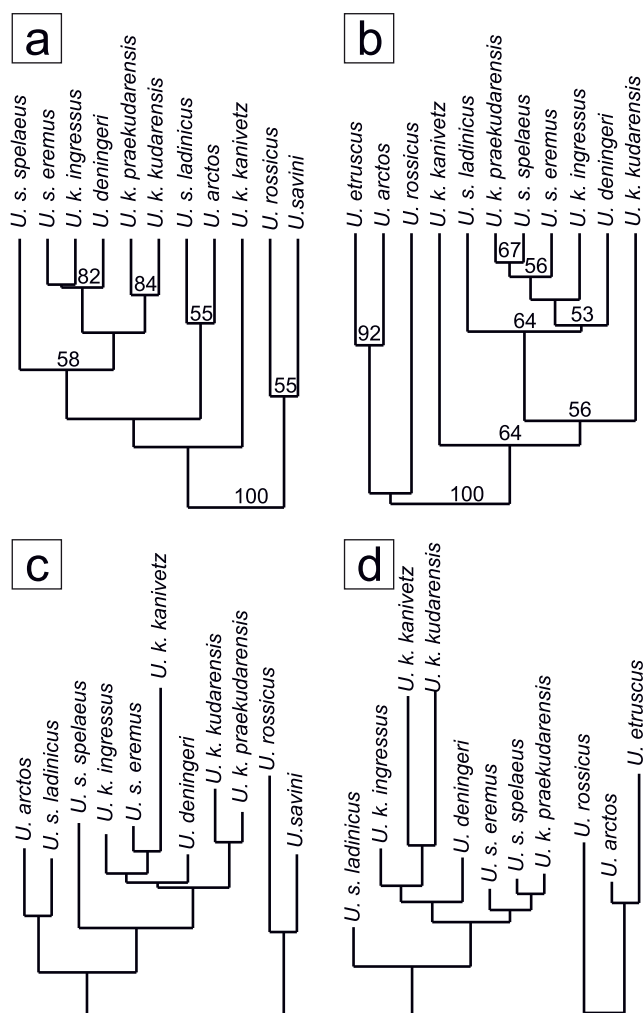

**Text-fig. 14. Classifications of centroids of bear samples in morphospaces (a, c – males, b, d – females). a, b – UPGMA dendrograms (cophenetic correlations – 0.89, 0.85); c, d – Sattath-Tversky (Sattath and Tversky 1977) additive trees. All classifications based on coordinates of joint samples of centroids of mtt V in size and shape morphospaces. Numbers near nodes – bootstrap (1000 repeats) supports >50%.**

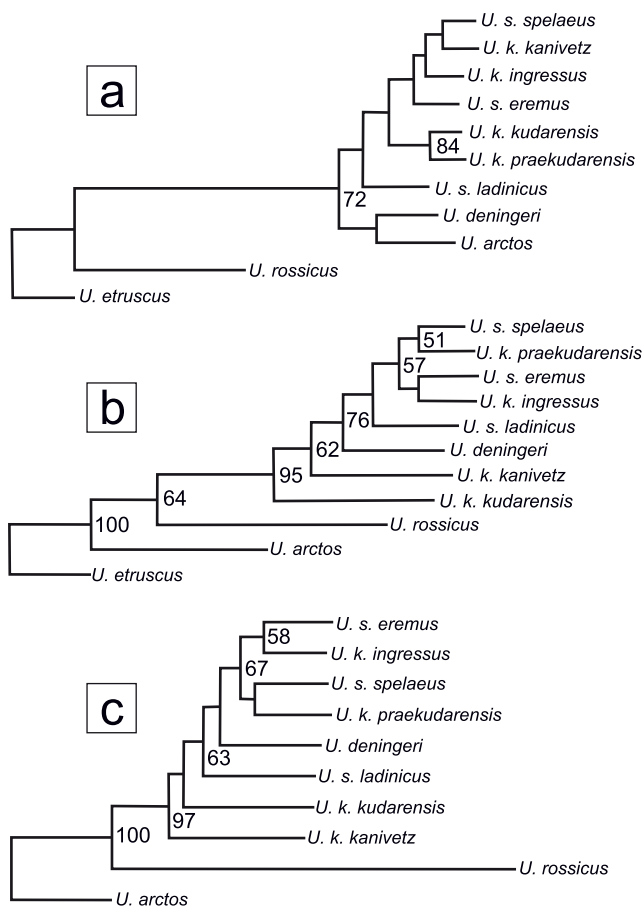

**Text-fig. 15. Consensus Bayes trees of centroids of bear samples in morphospaces. a – males, mtt III, IVs; b – female, mtt II, IV, and V; c – males and females together (mtt II – V). Numbers near nodes – bootstrap (1000 repeats) supports > 50%.**

multivariate analysis, set forth in section “Multivariate model of morphospace”, if a researcher has information about size of metapodia only, it is possible to confidently assign membership of the specimen to one of three groups: spelaeoid, *U. rossicus* and arctoid bears.

For more accurate identification, a researcher will need additional information about the geological age of a site or layer, results of an independent determination of taxa (in a given locality) using teeth and so on. The sites from Table 13 have different ages, from ~1.3 Ma BP to ~30 cal Kyr BP. In each case, we used information about the possible finding of one or two species of bear in a specific locality, which, together with information on the age, greatly simplifies the problem.

We used the Index of plumpness, because it is the least dependent on animal gender and bone length for presentation of the results. In Text-fig. 16a–d, the ellipses are ranges of *U. arctos* (low values of Index) and *U. deningeri* (high values of Index), which identify the main ranges of Index of plumpness and GL values for the arctoid and spelaeoid group respectively. Note that in construction of these ellipses, we excluded all problematic specimens/localities with ambiguous identification, mentioned in Table 13.

Using graphics presented in Text-fig. 16, we determined among others, that in the samples Deutsch-Altenburg 49

(~1.2–1.3 Ma BP), Deutsch-Altenburg 4B (~1.0–1.1 Ma BP) (Rabeder et al. 2010) and Deutsch-Altenburg 1 (~500–400 Kyr BP) (Nagel and Rabdere 1997, Rabeder et al. 2010), bones of the both deningeroid lineage and arctoid group representatives (Text-fig. 16a–d) are present; the specimen from probably the Late Biharian (~800 Kyr BP) Lažánky near Tišnov locality (Musil 1974) belonged to arctoid group (Text-fig. 16b). The position of the sample from Early Biharian (~1.1–1.0 Ma BP) Holštejn locality (Musil 1966; Fejfar and Horáček 1990) is not clear: mtc I (Text-fig. 16a) belongs to the deningeroid lineage of bears, but mtc IV (Text-fig. 16b) is placed between that and arctoid bears.

The bones from the Caune de l’Arago belong to Deninger’s bears and brown bears (both species were identified from this site (Moigne et al. 2006)). The remains from Kent’s (Kents) Cavern belong to *U. deningeri* (Text-fig. 16d) and *U. arctos* (Text-fig. 16a), from the Middle and Late Pleistocene layers (Higham et al. 2006, McFarlane et al. 2011).

In addition, we tested a small sample (ten bones; Tab. 13) from the multi-layered Acheulean cave site Sel’-Ungur, situated near Fergana Valley in Kyrgyzstan (Central Asia) (Vishnyatsky 1999), which was not included in statistical analysis. Age of the remains is not clear: Early to, most probably, Middle Pleistocene (Velichko et al. 1991). The bears from this site, characterizing by large cheek teeth, shortened metacarpal and metatarsal bones (Baryshnikov and Batyrov 1994), were described as subspecies *U. deningeri batyrovi* (Baryshnikov 2007). In Text-fig. 16b, c and d, the tested bones (abbreviation SU) fall into *U. deningeri* range, and in one case, near the edge of this range. Variability within the samples from the Sel’-Ungur Cave is within the variability of European populations of Deninger’s bears.

Finally, the above-mentioned difficulty in the identification of taxa within the group of big cave bears is illustrated in Text-fig. 16a. The mtc I from Grotte du Renne (Arcy-sur-Cure, ARC on the Text-fig. 16) apparently fall into the deningeroid group, and only additional knowledge about the Late Pleistocene age of the site (Baryshnikov and David 2000) and its geographical position (Yonne department, central France) allow us to identify this bone as most probably belonging to *U. s. spelaeus*.

The range of the deningeroid group includes all or most of the variation of the Index of other big cave bear taxa (Text-fig. 16e). Note that the range for small cave bears (*U. rossicus*) is below Deninger’s bears range, and ranges of *U. k. kudarensis* and *U. kanivetz ingressus*, which are higher, extend visibly out of the Deninger’s bears range (example for mtc V on Text-fig. 16e). This differentiation within the spelaeoid group mainly reflects disparity in bone sizes, whereas the Index of plumpness does not vary so significantly.

The relationships described between arctoid and spelaeoid groups depend on specific bones. Differentiation between them, for example, is more pronounced in mtc V then in mtt V (Text-fig. 16e, f). The last bone has a specific unintelligible feature in *U. k. kanivetz* (see section “Multivariate model of morphospace – Metatarsal bones”) that deviates from the other bears.

In conclusion, it is once again emphasized that identification of species from mixed samples poses significant

**Table 13. List of problematic specimens, tested in Section “Results – Problematic specimens”. Sample from Sel’-Ungur locality was not included in statistical processing.**

Locality	Country	Approximate age	Name of bone	Speculative identification
Süßenborn	Germany	? MIS 17 or MIS 16, ~0.70 or 0.65 Ma BP (Kahlke 1969, Bassinot et al. 1994)	mtc I, mtc III, mtc IV, mtc V, mtt V	<i>U. deningeri</i>
Einhornhöhle	Germany	“Cromerian complex”, ~0.85–0.50 Ma BP (Athen 2007)	mtt V	<i>U. deningeri</i>
Deutsch-Altenburg 1	Austria	Middle Pleistocene, ~0.45 Ma BP (Nagel and Rabeder 1997, Rabeder et al. 2010)	mtc I (2 specimens), mtc III, mtc IV, mtc V (2 specimens), mtt I, mtt II	<i>U. deningeri</i> (mtc I, mtc III, mtc IV, mtc V, mtt I, mtt II), <i>U. arctos</i> (mtc V)
Deutsch-Altenburg 4B	Austria	1.1–1.0 Ma (Rabeder et al. 2010)	mtc IV, mtc V, mtt III, mtt IV, mtt V	“deningeroid” lineage bear (mtc IV, mtc V, mtt III, mtt IV), arctoid group bears (? <i>U. arctos</i> ) (mtt V)
Deutsch-Altenburg 49	Austria	1.3–1.2 Ma (Rabeder et al. 2010)	mtt V	“deningeroid” lineage bear or bear of arctoid group
Holštejn	Czech Republic	zone B of Early Biharian (Fejfar and Horáček 1990), ~1.1–1.0 Ma	mtc I, mtc IV, mtt IV	“deningeroid” lineage bear
Lažánky near Tišnov	Czech Republic	Late Biharian (Musil 1974)	mtc IV	<i>U. arctos</i>
Grotte du Renne at Arcy-sur-Cure	France	MIS 3 (Baryshnikov and David 2000)	mtc I	<i>U. s. spelaeus</i>
Caune de l’Arago	France	MIS 16 – MIS 14 (Lumley et al. 1984)	mtc II (2 specimens), mtc III, mtc V, mtt IV	<i>U. deningeri</i> (mtc II, mtt IV), <i>U. arctos</i> (mtc II, mtc III, mtc V)
Kent’s (Kents) Cavern	United Kingdom	MIS 3 – MIS 2 (Higham et al. 2006); MIS 12 – MIS 11 (breccia) (McFarlane et al. 2011)	mtc I, mtc II (2 specimens), mtc III (2 specimens), mtt III, mtt V	<i>U. deningeri</i> (mtc III, mtt III, mtt V), <i>U. arctos</i> (mtc I, mtc II, mtc III)
Bol’shoy Glukhoy Grotto	Russia	MIS 5 – MIS 4 (Kosintsev et al. 2016)	mtc V, mtc IV (2 specimens)	<i>U. kanivetz</i> , <i>U. arctos</i> (mtc V)
Medvezhiya Cave	Russia	MIS 4 – MIS 3 (Kosintsev et al. 2016)	mtc IV (3 specimens)	<i>U. k. kanivetz</i>
Bol’shaya Vorontsovskaya cave	Russia	MIS 3, Late Pleistocene: according to preservation and coloration of the fossil bones	mtc IV	<i>U. arctos</i>
Sel’-Ungur	Kyrgyzstan	approximately 1.5 Ma, or much younger – Late Middle Pleistocene age (Velichko et al. 1991, Vishnyatsky 1999)	mtc IV (3 specimens), mtc V, mtt I, mtt III, mtt IV (2 specimens), mtt V (2 specimens)	<i>U. deningeri batyrovi</i>

difficulties in the absence of additional information; for example, trying to separate the bones of *U. s. eremus* and *U. k. ingressus* in Herdengel Cave, Austria (Döppes et al. 2016). In addition, it must be borne in mind that some specimens fall completely outside of ranges (arctoid or spelaeoid groups), because of high individual variability in cave bears metapodia. Such deviating individuals need special attention, if there is a possibility of mixed samples from the site.

## Discussion

### Sources of the morphological variability and disparity

#### *Sexual size dimorphism*

The full variance of any variable or measure, as is generally known, includes at least several components, namely 1) random variation, 2) factorial (non-random)

variations and effects on the variation from combinations of different factors, and 3) random error of measurement. In the case of multivariate model, such as morphospace, there are independent linear dimensions that contain the main part of variance of initial measures of the bones. The rest of the model variance includes a random component of variance (unexplained variance) in relation to the concrete model. We tested the quality of multivariate models with the help of multivariate linear regression models, where the initial measure was a dependent variable and dimensions of morphospaces were independent ones. Then, as the result of the test, we received evidence that the models described 70% – 90% of the initial variance of the measures in same-sex samples (Tabs 10, 12). Independent variances of dimensions provide the opportunity to effectively use variance components analysis (Searle et al. 1992) for estimation of the effects of potential factors, such as taxonomic composition of a sample, and sexual size dimorphism (all factors were

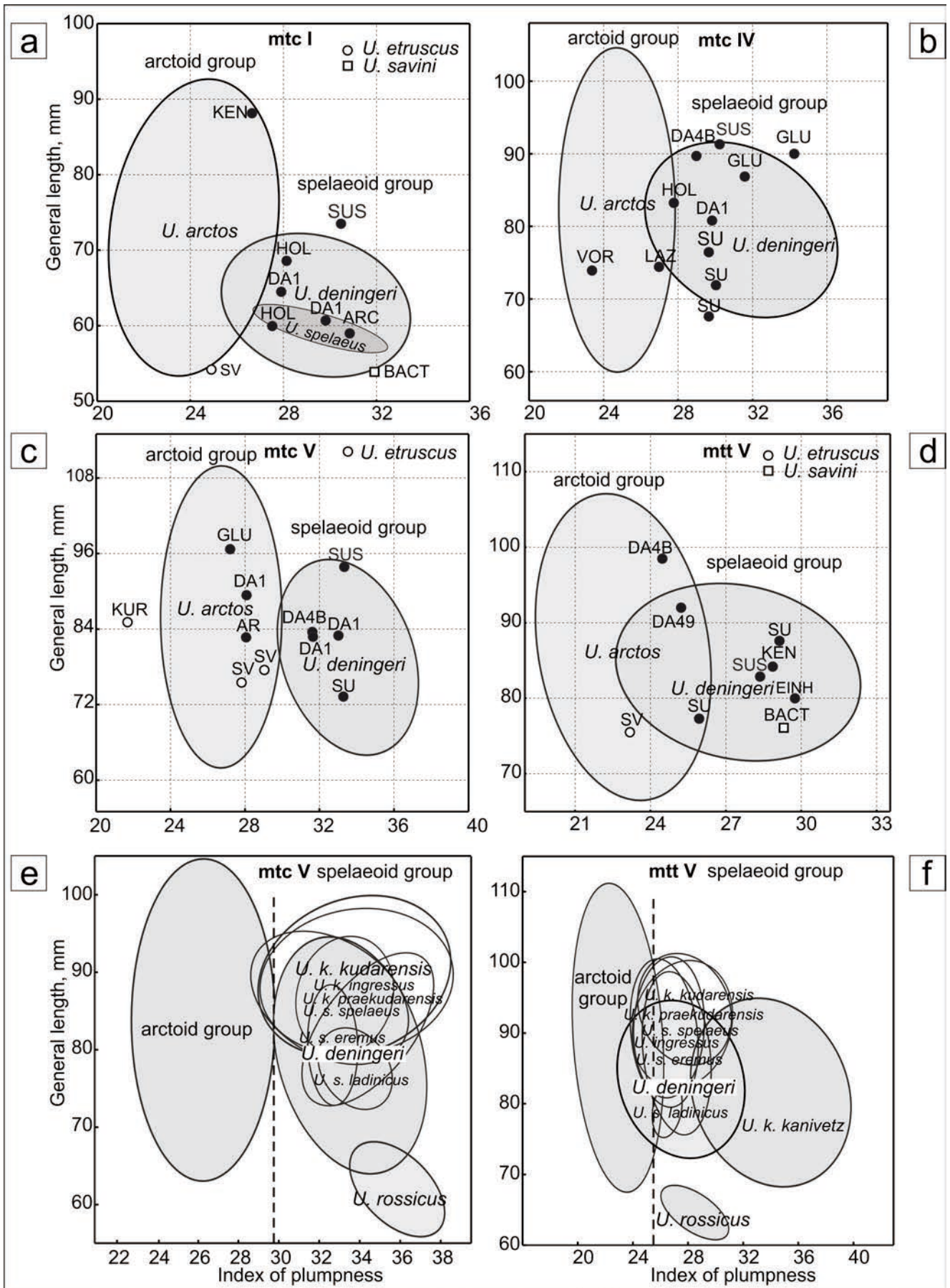

Text-fig. 16. a–d – examples of solving task on metapodial bones identifications from Table 13; e, f – ranges of arctoid and spelaeoid bears separated by Index of plumpness for mtc V and mtt V. Abbreviations of localities in text, Section “Materials and methods”.

interpreted as random in MANOVA, Type III model). Relationships of both these factors can be investigated in the framework of analogous multivariate models for joint male and female samples presented in Supplement I and II materials.

Table 14 contains information on relative components of variance that is associated with SSD and taxonomic compositions of samples for the morphospaces, which excluded *U. arctos*. Variances of the first dimension of size morphospaces are 44% (average of mtc I–V) and 38% (average mtt I–V), explained by the effect of sexual dimorphism. Effects of interspecific differentiation on variations in bone size are about 42% (mtc I–V) and 49% (mtt I–V). Low effects of interaction between tested factors were observed. Variance of the first dimension of the shape morphospace is practically independent from both factors (mtc I, mtt II, mtt III), effects of factor taxon are 23% – 57% (mtc II–V) and 35% – 52% (mtt I, mtt IV, mtt V), and effects of SSD factor – 29% (mtc V), and 35% (mtt V) (Tab. 14). In agreement with our main results presented above, sexual dimorphism and interspecific variability in many cases do not belong among factors that impact shape variation in metacarpals and metatarsals.

We can conclude that contribution of sexual dimorphism to bone size is close to a contribution associated with morphological disparity between bears belonging to different taxa, and hence the impacts of SSD on a result of any morphometric analysis of both metacarpals and metatarsals must be taken into consideration (Grandal-d’Anglade 1993).

Sexual dimorphism in cave bears has been studied by various authors (Kurtén 1955, Grandal-d’Anglade 1993, 2001, Jambrešić and Paunović 2002, Withalm 2004, Grandal-d’Anglade and López-González 2005, Toškan 2006, Robu 2016), but most studies focused on one or

a limited number of sites, and did not take into account the difference between geographical populations. SSD is detected for all investigated elements of the skeleton (skull, including teeth, and postcranial bones), but is not equal. In general, SSD of adult animals is more pronounced in size of canines, skull, mandible, and lengths of the limb bones. SSD varies significantly among different geographical samples (Grandal-d’Anglade 2001, Grandal-d’Anglade and López-González 2005).

According to our data (Baryshnikov and Puzachenko 2011), ASSD indexes for cave bear skulls were 3.4 (*U. rossicus*), 4.7 (*U. k. kanivetz*), 6.0 (*U. k. ingressus*), 4.8 (*U. s. eremus*), 6.7 (*U. s. spelaeus*) and 6.4 (*U. deningeri*). We did not detect well-marked correlation between sexual dimorphism in metapodia and skull, with the exception of small cave bears, *U. rossicus*, which has a low ASSD. Values of ASSD in brown bear skulls (two subspecies tested separately) were 7.7 (*U. arctos yesoensis* LYDEKKER, 1897) and 4.7 (*U. a. piscator* PUCHERAN, 1855). This reflects the potentially large variability of sexual dimorphism at the intraspecific level in bears.

According to presented data, sexual dimorphism of bear metapodia is higher than the sexual dimorphism of the skull, in general. The ASSD index for the both metacarpal and metatarsal bones in spelaeoid bears can vary widely, but does not exceed values typical for brown bears. On average, SSD in brown bears was higher, but at the intraspecific level in cave bears, the index is higher in many cases than that of brown bears.

The disparity between males and females, on average, is manifested more in metacarpal bones. This conclusion follows from the results presented in Section “Results – Sexual size dimorphism”, and from data in Table 14. In the cave bear group, among metacarpals, sexual dimorphism is higher in mtc I, mtc II and mtc V than in mtc II and mtc IV

**Table 14. Components of variance (%) of dimensions (E1, E2 and K1 – K3) of modeled morphological spaces, which associated with taxonomic composition (taxon) and size sexual dimorphism (SSD) in the samples, which do not include *U. arctos*. Statistically significant values ( $p < 0.05$ ) underlined.**

Components of variance	Bone	Dimension of model					Bone	Dimension of model				
		E1	E2	K1	K2	K3		E1	E2	K1	K2	K3
Taxon	mtc I	<u>32</u>		0	11		mtt I	<u>50</u>	<u>36</u>	<u>52</u>	<u>18</u>	11
SSD		<u>50</u>		1	<u>4</u>			<u>36</u>	3	0	5	0
taxon and SSD		5		7	0			3	8	2	6	2
Taxon	mtc II	<u>51</u>	<u>46</u>	<u>57</u>	8		mtt II	<u>51</u>	1	10	<u>19</u>	
SSD		<u>36</u>	4	0	0			<u>33</u>	3	0	0	
taxon and SSD		3	3	3	5			4	3	5	0	
Taxon	mtc III	<u>31</u>	<u>32</u>	<u>24</u>	<u>40</u>	1	mtt III	<u>42</u>		9	<u>18</u>	
SSD		<u>55</u>	0	8	8	0		<u>42</u>		5	1	
taxon and SSD		2	5	12	0	<u>17</u>		4		3	0	
Taxon	mtc IV	<u>53</u>	<u>25</u>	<u>23</u>	9		mtt IV	<u>54</u>	<u>29</u>	<u>35</u>	<u>33</u>	
SSD		<u>33</u>	0	5	9			<u>33</u>	4	2	0	
taxon and SSD		1	20	8	8			3	0	1	3	
Taxon	mtc V	<u>42</u>	<u>37</u>	<u>29</u>	7		mtt V	<u>48</u>	<u>58</u>	<u>50</u>	<u>43</u>	
SSD		<u>45</u>	2	0	<u>22</u>			<u>35</u>	0	0	3	
taxon and SSD		2	0	9	0			7	0	3	0	

(Text-fig. 4b, Tab. 14), but at the same time, all metatarsals have about the same level of sexual dimorphism (Text-fig. 6b, Tab. 13). The disparities between different metacarpals and metatarsals in brown bears are even more pronounced. In this case, mtc II has significantly higher ASSD than other bones, and among metatarsals, mtt V has a significantly lower value of ASSD (Text-figs 4c, 6c). The origin and nature of this phenomenon is unclear; we can only assume that specific features of ontogenetic growth of different bones somehow cause it.

Sexual size dimorphism is a typical phenomenon of carnivores, but when sexual dimorphism is discussed, it must be remembered that this parameter is not a strong species-specific constant. It has already been pointed out that different subspecies of brown bears have different levels of sexual dimorphism of the skull and cheek teeth (Baryshnikov et al. 2003, Baryshnikov and Puzachenko 2011). Among mustelids (Mustelidae), for example, significant spatial variations in degree of SSD were found in all studied species (Reichstein 1957, Zyll de Jong 1992, Lynch et al. 1996, Abramov and Baryshnikov 2000, Abramov and Puzachenko 2009, Abramov et al. 2016).

Not enough information is available about change of degree of sexual dimorphism in an ecological time scale. We can mention here the Powell and King study (1997), showing that dimorphism in stoat (*Mustela erminea* LINNAEUS, 1758) differs among demographic cohorts, and is positively depended on food abundance. Another example (Baryshnikov and Puzachenko 2012) described a potential temporal variation of sexual dimorphism of skull in Eurasian otters (*Lutra lutra* LINNAEUS, 1758), because it is positively highly correlated with temperature ( $r = 0.76$ ) and precipitation ( $r = 0.68$ ) of January, i.e. with the ecological conditions during the most difficult period of otters' annual living cycle. Since variations in size of different carnivores in ecological time scales have been observed (Yom-Tov et al. 2003, 2006, 2007, 2013, Monakhov 2014), there is no reason to exclude such a possibility for cave bear populations in the past.

Here we give one example illustrating the possibility of change in sexual dimorphism within one palaeopopulation of *U. k. kudarensis* from the Akhstyrskaya Cave (North-West Caucasus). In the lower Mousterian layers, dated approximately MIS 8 – MIS 5 (Baryshnikov 2012), SSD of the smallest breadth in the medial part of the diaphysis (SD) is 2.1, while in the upper Mousterian layer (MIS 3, about 40 cal Kyr BP) (Churchill and Smith 2000) it is 3.1, and in the Upper Palaeolithic layer (MIS 3 – MIS 2, 30–22 cal Kyr BP) (Baryshnikov 2012) it is 4.2. All numbers are small and typical for this cave bear, but the sample size is also small, and Text-fig. 17a illustrates the likely possibility of size sexual dimorphism variation only.

Withalm (2001) concluded that it is not possible to determine sex in a cave bear population only by means of metapodials, due to inhomogeneous results. His conclusion is true without doubt for result of univariate analysis, in relation to single measurements of metapodial bone when a distribution of measure, for example GL, usually is not bimodal. However, the use of many measurements within the framework of multivariate analysis makes it possible to order "observations" and obtain bimodal distributions of

generalized variables, such as the first principal component in PCA (Toškan 2006). Athen (2009) demonstrated high accuracy (errors <8%) sex identification by measuring different metapodial bones in samples of recent brown bears, using discriminant analysis. In our study, we used multivariate nonparametric dichotomous cluster analysis (Puzachenko et al. 2004), which is useful for small samples also (for samples containing dozens of bones, K-means clusters analysis can be used equally well). The results of initial clustering were then corrected using discriminant analysis. Testing this approach on a sample of brown bears with known sex gave satisfactory results. Nevertheless, it must be understood that splitting a sample into two morphological classes (presumably males and females) obtained in this way will never be certain. Potential errors can exceed ten percent, depending on what metapodial bone is investigated.

#### *Spatial and temporal variation*

The last study of ancient mtDNA (Fortes et al. 2016) shows that each of some closely situated caves (North Spain) almost exclusively contains a unique lineage of closely related haplotypes, and so suggests extreme fidelity of *U. spelaeus* to their birth site, at least in females (homing behavior). These data correspond to results of the study of strontium isotope ratios ( $^{87}\text{Sr}/^{86}\text{Sr}$ ) in *U. spelaeus* dentin and enamel (Ábelová 2006) that suggests limited movement of bears during their lifetime. This feature of behavior, which can lead to constrains of gene flow, and other environmental factors (height above sea level of habitat, orography, climate evolution), as well as evolutionary trends may act as a factors of high individual and group morphological variability of cave bears in different sites (Jambrešić and Paunović 2002, Athen et al. 2005, Carlis et al. 2005, Santi and Rossi 2005, Toškan 2006, Rabeder et al. 2008, Toškan and Bona 2012, Krajcarz et al. 2016, Robu 2016, and others).

Investigation of spatial and temporal intraspecific variations in cave bears is a special problem, which is not the main target of this study. However, as an illustration of potentially high reversible or ambiguous morphological variability of cave bears, three examples will be considered.

The whisker plots in Text-fig. 17b shows mean values of length (GL) and SD of mtt I in *U. k. kudarensis* of uneven-aged layers of Akhstyrskaya, Kudaro 3 and Kudaro 1 caves. Sizes of bones in the Lower Mousterian layers are smaller than in the Upper Mousterian, while in Upper Paleolithic layers, these bones decrease in size. This is true for both male and female SD. The measure GL in males during that same time probably did not undergo changes between the Upper Mousterian and Upper Paleolithic time. In the last case, we have not enough data to analyze this adequately.

In the second example, we present variation of length of mtt III and IV in *U. deningeri* s. l. from several localities. In Text-fig. 17c and 17d, the oldest locality is Deutsch-Altenburg 4B (DA4B) (1.1–1.0 Ma BP; Rabeder et al. 2010), the youngest is Kent's Cavern (~0.50–0.37 Ma BP, breccia level; McFarlane et al. 2011); Einhornhöhle ("Cromerian complex", ~0.85–0.50 Ma BP; Athen 2007), Caune de l'Arago (AR) (~0.67–0.53 Ma BP; Lumley et al. 1984), Mosbach 2 (~0.62–0.48 Ma BP; Maul et al.

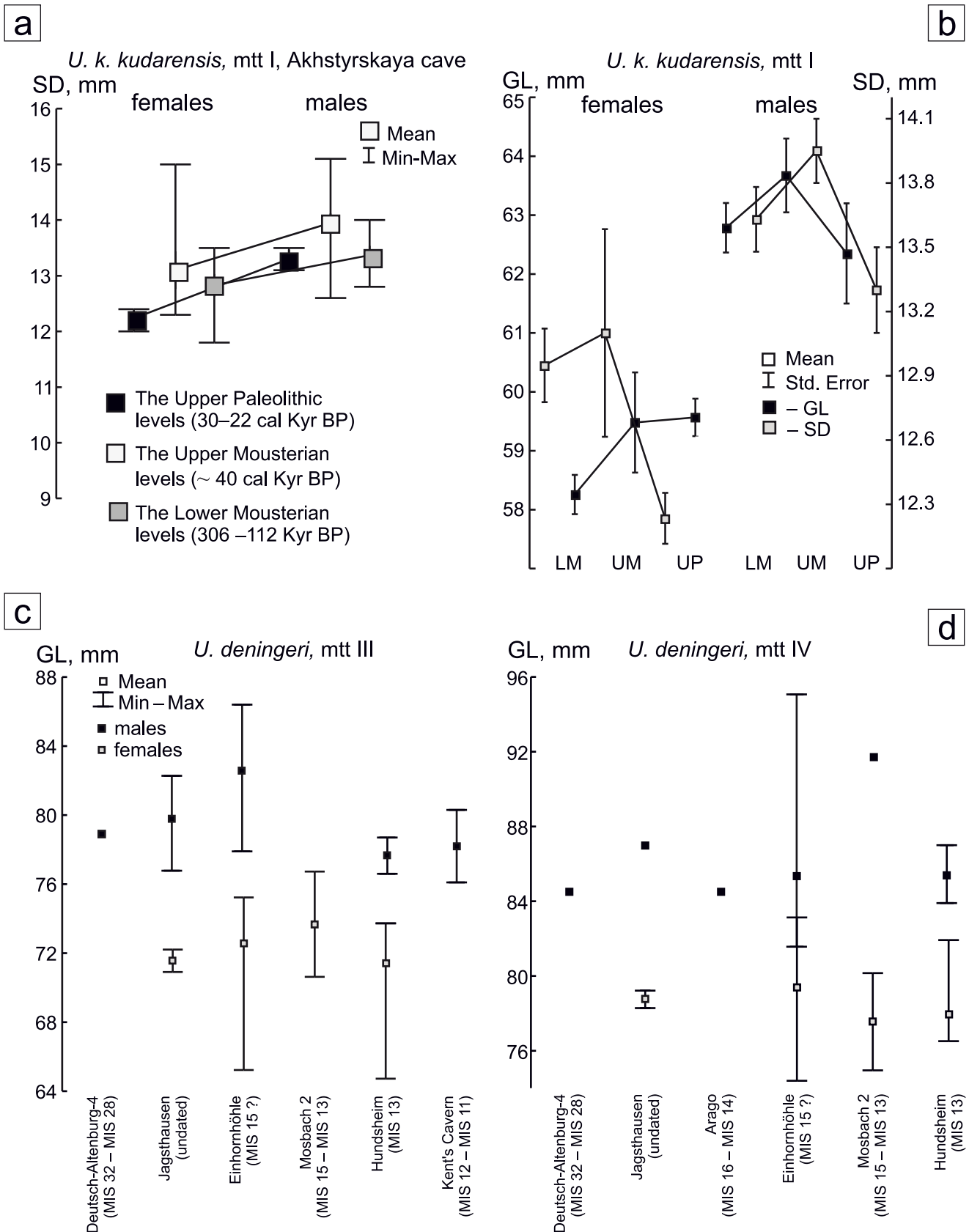

Text-fig. 17. a – sexual size dimorphism of mtt I on smallest breadth in medial part of diaphysis (SD) in *U. k. kudarensis* from different layers of Akhstyrskaya Cave; b – temporal variation of length (GL) and SD of mtt I in *U. k. kudarensis* from different layers of Akhstyrskaya Cave, Kudaro 3 and Kudaro 1 caves (LM – Lower Mousterian, UM – Upper Mousterian, UP – Upper Paleolithic layers); c, d – variation of GL of *U. deningeri* mtt III and IV from different sites (Kahlke 1961, Lumley et al. 1984, Keller 1994, Maul et al. 2000, Falguères et al. 2004, Rosendahl et al. 2005, Athen 2006, Lundberg and McFarlane 2007, Döppes et al. 2008, Mlíkovský 2009, McFarlane et al. 2011, Rabeder et al. 2010, Kahlke et al. 2011).



2000), Hundsheim (~0.50 Ma BP, MNQ 22; Mlíkovský 2009), and Jagsthausen Cave (may be Middle Pleistocene, Early Toringian) is undated. In cases where we had a relatively large amount of data (Hundsheim and especially Einhornhöhle), a large spread of values was observed in male and female groups. According to this, there are no any evolutionary trends in general size of the bones. The range of GL of mtt III and IV from Einhornhöhle for both sexes overlaps all other ranges from our *U. deningeri* sample. In this case, it is possible that samples of Deninger's bears were some contaminated by *U. spelaeus* bones, because both species were observed in this cave (Athen and Pfreundtner 2005, Athen 2006).

The last example (Text-fig. 18) shows variation of mtt III in cave bears belonging to the Late Pleistocene *kanivetz=ingressus* haplogroup (Nagel et al. 2005, Tsoukala et al. 2006, Toškan 2007, Baca et al. 2012, Withalm 2014, Robu 2016), from ten localities. These localities range from Poland and Greece in the west, to the Volga River and Ural Region in the east. In the west part of the palaeorange (*U. k. ingressus*), there is no appreciable difference between the sites. Within Ural cave bears (*U. k. kanivetz*), we also cannot identify any location specifically. It may be that cave bears from the Ural Mountains were somewhat smaller than western ones, but the overlap between them on mtt III size

is very significant. We used published data (see references above) on the length of mtt III for comparison from Loutra Arideas Bear Cave (Greece), Urșilor Cave (Romania), Križna jama, Divje babe I (Slovenia), and Nerubajskoe (Ukraine). Unfortunately, since the authors did not divide the samples into males and females, it is impossible to assess the real scale of variability (except Divje babe I, sample Db-A, MIS 3 (Toškan 2007)) (Text-fig. 18). Nevertheless, in all localities the average lengths of mtt III fall within the range of variation estimated by our samples, except Divje babe I, where an extremely low value (min = 66.1 mm) was observed (not shown on the figure). It is most likely that this bone does not show a significant spatial (geographical) pattern. It is possible, however, that metatarsal bones of bears from Eastern Europe (southern Ukraine, Volga River region) really were larger, or SSD was more pronounced in these geographic populations than in Southern and Central Europe regions.

The present examples on one hand again demonstrate high individual morphological variability of bones under investigation that we have shown above on multivariate analysis results. On the other hand, these examples once again point up the necessity to separate a sample set into male and female subsamples before a meaningful statistical analysis can be conducted.

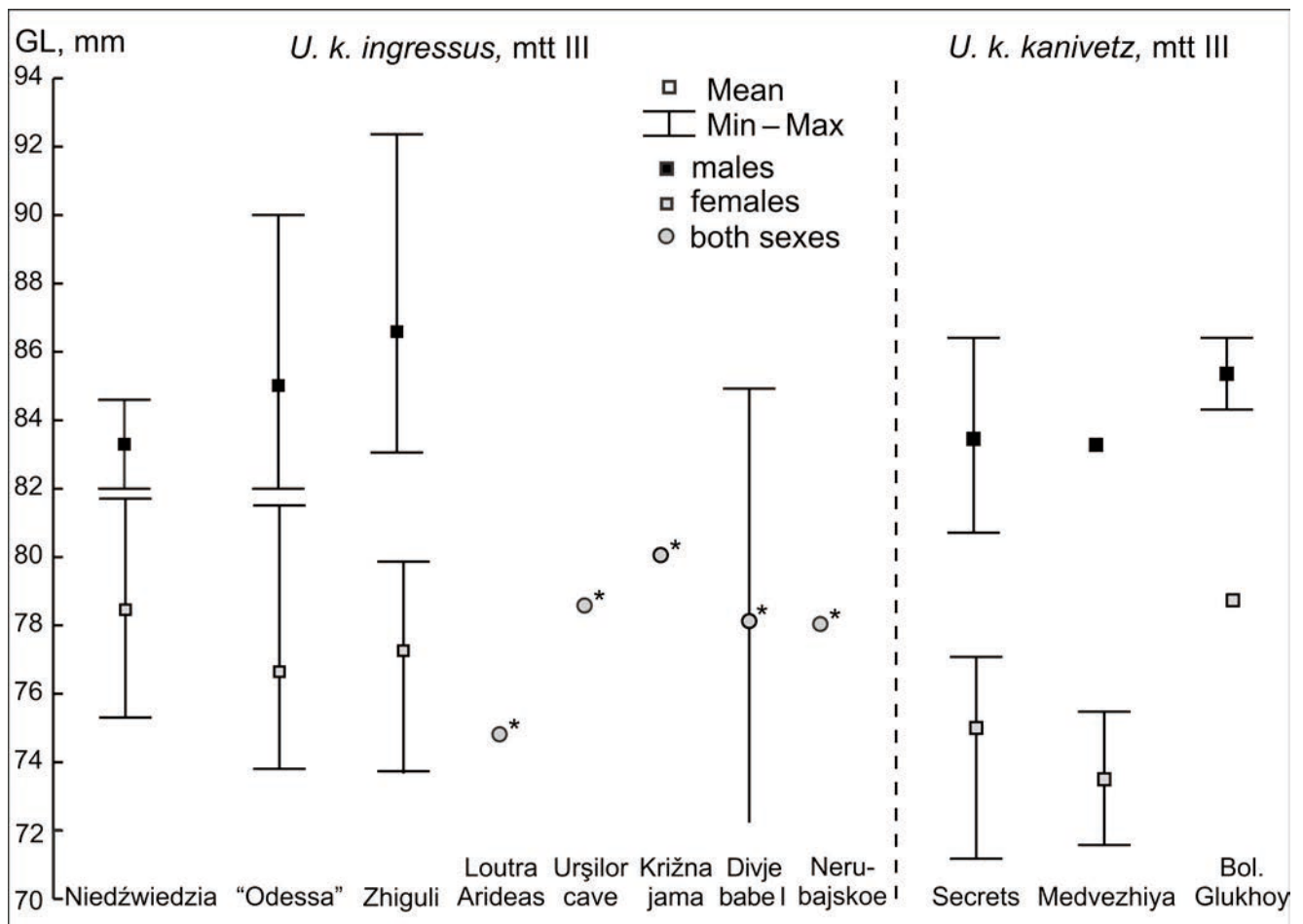

Text-fig. 18. Length of mtt III in *U. k. kanivetz* and *U. k. ingressus* from different European sites. "Odessa" – Nerubajskoe and Karantinnaya Balka. \* – data were taken from literature: Loutra Arideas Bear Cave (Tsoukala et al. 2006), Urșilor Cave (Robu 2016), Križna jama (Withalm 2014), Divje babe I (Toškan 2007; Db-A sample), Nerubajskoe (Nagel et al. 2005).

## Morphological differentiation of bears on metacarpal and metatarsal bones

Univariate analysis (Section “Results – Univariate analysis”, Supplement I and II) showed few measurements of metapodial bones for which we can assume “statistically significant” morphological distinctions across chronospecies within the group of large cave bears. We cannot argue that the measurements selected in the present study will “work” for samples yielded from specific paleontological sites. Moreover, it is possible that in each case, there will be detected particular measurement or combinations of measurements/indexes that “statistically significantly” divide a sample into, for example, subsamples of *U. deningeri* and *U. spelaeus* bones (Leney 2000, Athen 2007). Multivariate analysis (Section “Results – Multivariate model of morphospace”, Supplement I and II) also showed ambiguous relationships between big cave bear taxa dependent on sex and metapodial bones. Thus, results of morphometric analysis will obviously depend on the peculiarities of the particular sample, the number of localities included in the study, their geographical locations, and geological ages against the general background of the continuous spatial/temporal morphological variability in the chronospecies from the big cave bears group.

Based on data presented in Sections “Results – Univariate analysis” and “Results – Multivariate model of morphospace” (Text-figs 7, 9, 10, 12, 13 and 15), it can be assumed that taxa are more differentiated on parameters of metacarpal bones, and they are more similar to each other on parameters of metatarsal bones. Since the main collision here is differentiation between arctoid and spelaeoid bears, we can test this hypothesis quantitatively using canonical discriminant analysis. The group of arctoid bears includes two chronospecies – *U. arctos* and *U. etruscus*, and the group of spelaeoid group includes all other taxa. We use the Squared Mahalanobis distance as measure of morphological similarities/dissimilarities, and the coordinates of morphospaces (E and K) as independent variables in the discriminant analysis. Results of the tests for males and

females are shown separately in Table 15. As may be seen, on average two groups of bears had better differentiation precisely by metacarpal parameters. The disparities between the arctoid and spelaeoid groups on the first and second metacarpals and first metatarsal are noticeably stronger. In addition, there is a tendency towards sexual dimorphism, in that differentiation between males is less pronounced than between females.

Variation in size and shape of paws bones is associated with adaptations for locomotion of bears. The foot mainly implements function of jogging (when running) or function of support (when climbing or moving on hind limbs), while the forepaw is a polyfunctional organ, used when running, foraging, attacking, defending and so on. Probably the difference between the relatively gracile arctoid and massive spelaeoid fore limbs, and especially forepaws reflect the differences in their diets, agility, mobility, resistance to physical (static or dynamic) exercise, and in ways of life overall (Leney 2000, Petronio et al. 2003).

Limb loading depends on the body mass of animal and environmental conditions. According to Jambrešić and Paunović (2002), movement of cave bears was similar to the semi-plantigrade locomotion of brown bears, but with somewhat more expressed plantigrade on the hind limbs. Hind limbs proportions are largely uniform across mammals in comparison with the high degree of variability in forelimb proportions, which is dependent on adaptations (Schmidt and Fischer 2009). Therefore, from an evolutionary perspective, morphology of hind paws in bears is probably more conservative, while forepaw anatomy varies greatly, depending on specific adaptations to local environmental conditions (Jambrešić and Paunović 2002, Rabeder et al. 2010, Toškan and Bona 2012).

Our analysis showed that metatarsal bones of all studied arctoid and spelaeoid bears are closer structurally to each other than metacarpal bones, as result of common adaptation to terrestrial lifestyle. The metacarpals, at the same time, show clear differences between arctoid and spelaeoid taxa, which is manifested especially in bone thickness/plumpness.

**Table 15. Squared Mahalanobis distances ( $D_M$ ) between centroids of arctoid and spelaeoid bear samples according to discriminant analysis.**

Sample	Sex	$D_M$	Sample	Sex	$D_M$
mtc I	males	20.7	mtt I	males	14.8
	females	20.2		females	29.5
mtc II	males	19.9	mtt II	males	6.9
	females	22.5		females	14.6
mtc III	males	10.0	mtt III	males	2.2
	females	10.1		females	7.1
mtc IV	males	12.0	mtt IV	males	1.1
	females	15.9		females	6.6
mtc V	males	15.9	mtt V	males	5.0
	females	19.1		females	16.4
<b>Average</b>		16.6	<b>Average</b>		10.4
males		15.7	males		6.0
females		17.5	females		14.8

This last feature likely reflects high loading on the bone in cave bears, and on more specialized fore limbs especially, in comparison with brown bears. Perhaps that paw of cave bears (mainly herbivores) was more specialized for digging underground bulbs and rhizomes (Mattson 1998). This nutrient diet allowed cave bears to exist in temperate latitudes and accumulate fat reserves they needed for long-term winter hibernation.

### Notes on evolution of spelaeoid bears

Our study reveals that sizes and shapes of metacarpal and metatarsal bones are not associated with taxonomical or evolutionary position of cave bears; in other words, we failed to discern a phylogenetic signal. Therefore, we restrict ourselves by superposition of the obtained data on metapodia of cave bears and brown bears onto their phylogenetic tree and onto the geological scale.

The ancestor of both cave bears and brown bears is regarded to be *U. etruscus* from the Early Pleistocene of Europe, Asia, and Northern Africa (Kurtén 1968, Baryshnikov 2007). Mazza and Rustioni (1992) suggest that cave bears did not originate from the later *U. etruscus* characterized by specialized dentition, but from the earlier *U. arctos*. However, this hypothesis conflicts with cladistical analysis of morphological characters (Baryshnikov 2007), as well as with results of studying ancient cave bear mtDNA (Hofreiter et al. 2002, Valdiosera et al. 2006, Dabney et al. 2013, Baca et al. 2014). Mitochondrial phylogeny assumes that divergence of cave bears from brown bears occurred nearly 1.2 Ma BP (Loreille et al. 2001), or maybe considerably earlier, 3.57 – 2.1 (mean is 2.75) Ma BP (Krause et al. 2008). The first data approximately coincides with a time of existence of the last Etruscan bears, whose Asian populations could give rise to cave bears. If the last estimate of divergence time is correct, the ancestor of cave bears and brown bears might be an early *U. etruscus*, but we do not have such old finds of bears that belong to the cave bear lineage.

The present study uncovered morphometric similarity of metacarpal and metatarsal bones of early *U. etruscus* with those of *U. arctos*, as well as their pronounced sexual dimorphism in size. Brown bears had presumably inherited locomotor adaptations from Etruscan bears, and their metapodial bones underwent very slight changes in the course of evolution, only increasing their size. The early history of *U. arctos* is known only fragmentarily. Rabeder et al. (2010) referred all earliest European arctoid-like bears to *U. suessenbornensis* SOERGEL, 1926 (Süßenborn group), and included into this taxon materials from the localities of Süßenborn and Deutsch Altenburg 4B, 49. In our sample from Deutsch Altenburg 4B, both arctoid bears (one bone) and deningeroid group bears (four bones) were found. The single bone (mtt V) from the older Deutsch-Altenburg 49 belonged to a bear of deningeroid lineage. In the younger Süßenborn locality, we identified only *U. deningeri* (five bones). Our data provides grounds to assume the existence of large cave bears (deningeroid lineage) in Europe since the time of the Early Pleistocene (pre-Jaramillo, older than 1 Ma).

Our results do not fully agree with the results from Rabeder et al. (2010). This may be due to differences in

materials and methods of data analysis. First, we used the Index of plumpness according to Withalm (2001), which exhibits a lower level of SSD and has no allometric pattern (practically independent from GL, Text-fig. 7e, f), in comparison with direct measurements of bone, such as its length and thickness of diaphysis. Second, we investigated only metapodial bones, while the conclusions of Rabeder et al. (2010) were based on data about variability in teeth, mandible bone, and phalanges. Here we should not exclude the possibility of different evolution rates in various elements of the skeleton and dentition when interpreting the data. Finally, it should be emphasized that the results may depend on which sample or samples were used as standards for the spelaeoid or arctoid bears in a particular study.

Based on our results, we believe that the Index of plumpness is useful to discriminate between arctoid s. l., including *U. etruscus*, and spelaeoid s. l. bears in mixed samples, or from different localities, with varying errors depending on the specific metapodial bones (the best results were observed for mtc V in our study). In general, we did not find a “smooth transition” in the shape of metapodial bones between arctoid and spelaeoid bears. Therefore, it is possible that the thickening of metapodials with the weight of the skeleton on the whole, which is one of the characteristics of cave bears, occurred early in the divergence of both evolutionary lineages (at the end of the Pliocene?) during a relatively short time interval.

Among three major genetic lineages of cave bears (spelaeus, kanivetz=ingressus, and kudarensis haplogroups), the one which leads to *U. kudarensis* diverged earliest (Stiller et al. 2014). The time of its splitting from the *U. spelaeus* s. l. lineage is ascertained to be the interval from 0.814 to 0.274 Ma BP (Knapp et al. 2009), but most probably, this event occurred still earlier. Phylogenetic analysis, which used data of ancient mtDNA extracted from a Middle Pleistocene cave bear (*U. deningeri*) bone excavated at Sima de los Huesos in the Sierra de Atapuerca, Spain, revealed a basal position of *U. kudarensis* with regards to all cave bears, including *U. deningeri* (Dabney et al. 2013). Therefore, it seems logical to suggest that *U. kudarensis* could have preserved a plesiomorphic state of the shape of manus and pes among examined cave bear taxa. However, we found no significant distinct morphometric differences of metacarpal and metatarsal bones between representatives of examined genetic groups, which imply a stability of their structures in the history of the cave bear group. Basic adaptations of cave bears to locomotion and foraging obviously formed very rapidly at the earliest stages of their evolution (another striking example of fast evolutionary changes is demonstrated by the polar bear, *U. maritimus*). Having been separated from the early Etruscan-like bears (like the bear from Kuruksay locality with the extremely thin metapodials, Text-fig. 16c), they created a new life-form occupying a peculiar ecological niche of northern phytophagous bears, which has no current analogues.

Small cave bears *U. rossicus* are well differentiated from large cave bears by the shape of their metapodial bones. A similarity of this taxon with *U. savini* is observed. However, it is still unclear whether this similarity is associated with the small size of these bears, or whether it can be explained by their phylogenetic relationship and similar lifestyle.

Our study affiliates *U. savini* with bears grouped near or within the *U. deningeri* morphological range (Text-fig. 16a, d), which confirms the analogous hypothesis stated previously (García 2003, Grandal-d'Anglade and López-González 2004; Rabeder et al. 2010). The earliest findings of *U. rossicus* have been recorded in localities dated to the second half of the Middle Pleistocene of Europe and Siberia (Baryshnikov and Foronova 2001), which testifies to its relatively early phylogenetic splitting within the spelaeoid lineage.

Concerning the evolution of large cave bears from the spelaeus and kanivetz=ingressus haplogroups, it is worth noting that there is a pronounced morphometric difference between geographically separated populations of bears from Urals and Eastern and Central Europe. Presumably, this difference can be explained by a different history of bears in these two regions. Having originated in the eastern regions of their distributional range, bears from this haplogroup began to disperse westwards, preserving more primitive cranial features in Urals (Baryshnikov and Puzachenko 2011). During their expansion in cold epochs of the Late Pleistocene, these bears pressed representatives of *U. spelaeus* to the western regions of Europe and to highlands of the Alps. This hypothesis has been formulated by us during the analysis of craniometrical variability of cave bears (Baryshnikov and Puzachenko 2011).

According to the data by Baca et al. (2014), *U. k. ingressus* from Niedźwiedzia Cave in Poland is genetically closely related to animals from Urals (Bol'shoy Glukhoy grotto, Medvezihaya Cave, Serpievskaya Cave) and next, to the Slovenia (Divje babe). In the Sudetes, these bears presumably appeared at MIS 5a to the beginning of MIS 4. In other regions of Eastern Europe, the kanivetz=ingressus haplotype displays a noticeably later time of appearance (MIS 3); meanwhile, early dating (>52 Kyr BP) has been recorded for *U. k. ingressus* from the environs of Odessa (Nerubajskoe) (Pacher and Stuart 2009). It can be hypothesized that there were several waves of occupation of Eastern Europe by this taxon in the Late Pleistocene: in different time and from different regions.

## Conclusion

In this study, we used the material that characterizes a morphological variability in metapodial bones of different genetic groups of cave bears on large temporal and geographic scales. Univariate and multivariate analyses showed significant individual and group (SSD) variability with fuzzy and unstable morphological differences within subgroup of large cave bears, including *U. deningeri* s. l. (*U. savini* included), *U. spelaeus* s. str., *U. kanivetz* (= *ingressus*) and *U. kudarensis*. Therefore, we could not get morphological classifications with clear phylogenetic signals, and that would be isomorphic to the classifications obtained earlier by ancient mitochondrial DNA.

This general conclusion does not exclude that the picture of morphological differentiation between, for example, *U. deningeri* s. l., *U. spelaeus* s. str., can be made more clear if the scale of the study is changed, that is, in cases where samples from a single site or from several geographically

closely located sites are analyzed or when their deposits are similar in age.

Small cave bears, *U. rossicus*, on this background, are morphologically well distinguished by size from other spelaeoid bears. Herewith, the shape of metapodial bones in this species has all the key character features of big cave bears.

In accordance with the result of our morphometric study of metapodia, the cave bear lineage tree (or more realistically, bush) includes *U. deningeri* s. l., *U. rossicus*, *U. kudarensis*, *U. spelaeus* s. l. (included are all subspecies of *U. spelaeus* s. str. and *U. kanivetz* (= *ingressus*)).

The second general conclusion of our study is that a relatively compact group of cave bears is morphologically contrasted with a less homogeneous arctoid group, which in this study includes only *U. etruscus* and *U. arctos* s. l. Morphological data do not contradict the phylogenetic hypothesis of their relationships as ancestor-descendant. These data do not allow proposing the same relationships between the late *U. etruscus* and *U. deningeri* s. l., that partly supports the assumption by Mazza and Rustioni (1992) based on features of dentition. In addition, it is obvious enough that early variants of brown bear lineage inheriting signs of late *U. etruscus* cannot be ancestors of cave bears. Therefore, and taking into account the results of genetic reconstructions of the divergence time between arctoid and spelaeoid lineages, we are obliged to assume origin of the latter from early Etruscan-like bears that inhabited, most probably, Northern Asia. In that case, early Kudaro-like bears are likely the basal taxon for all cave bears. Probably, further rapid splitting of the spelaeoid lineage into Asian and European parts led to separation of eastern cave bears (*U. kudarensis* s. l.) from western cave bears of deningeroid lineage.

## Acknowledgements

The authors thank Prof. V. P. Lioubine, Dr. S. Kulakov and Dr. N. Garutt (St. Petersburg), Dr. E. Mashchenko (Moscow), Dr. T. Krakhmalnaya and Dr. D. Ivanov (Kiev), Dr. P. A. Tleuberdina and Dr. G. Nazimbetova (Almaty), Prof. B. Batyrov (Samarkand), Prof. A. Lister and late Dr. A. Currant (London), Dr. V. Eisenmann and Dr. F. David (Paris), late Prof. C. Guerin (Lyon), Prof. C. Petronio (Roma), Dr. W.-D. Heinrich (Berlin), Prof. R.-D. Kahlke (Weimar), Prof. R. Ziegler (Stuttgart), Dr. H. Lutz and Mr. T. Engel (Mainz), Dr. A. Broschinski (Hannover), Prof. G. Rabeder, Dr. M. Pacher and Dr. U. Göhlich (Vienna), late Dr. A. Forsten and Prof. M. Fortelius (Helsinki), Dr. J. Wagner (Prague), Dr. M. Galetová (Brno), Prof. A. Nadachowski (Krakow) for providing access to collections. Julia Shemyakina (St. Petersburg) helped in studying Kudaro cave bear limb bones. Svetlana Baryshnikova (St. Petersburg) assisted us in work with the manuscript. We are especially grateful to the reviewers: Dr. Jan Wagner (Prague) and Dr. Borut Toškan (Ljubljana).

The study was fulfilled within a framework of the Federal theme of the Theriology laboratory of Zoological Institute RAS no. AAAA-A17-117022810195-3 "Phylogeny, morphology and systematics of placental mammals" (GB),

and was financially supported by the Russian Foundation for Basic Research: GB (grant No. 16-04-00399-a) and AP (grant No. 13-05-0056-a); and (AP) the state scientific theme of Institute of Geography RAS no. 69.2 “The mammalian fauna of the boreal and subarctic regions of northern Eurasia during the Late Pleistocene and Holocene: taxonomic composition, diversity, and evolution”.

## References

- Ábelová, M. (2006): Migration pattern inferred from *Ursus spelaeus* Rosenmüller tooth from Tmavá skala cave (Slovak Republic) using strontium isotope analyses. – Scientific Annals, School of Geology Aristotle University of Thessaloniki (AUTH), Special volume 98: 123–126.
- Abramov, A. V., Baryshnikov, G. F. (2000): Geographic variation and intraspecific taxonomy of weasel *Mustela nivalis* (Carnivora, Mustelidae). – Zoosystematica Rossica, 8: 365–402.
- Abramov, A. V., Puzachenko, A. Yu. (2009): Spatial variation of sexual dimorphism in the Siberian weasel *Mustela sibirica* (Mustelidae, Carnivora). – Russian Journal of Theriology, 8(1): 17–28.
- Abramov, A. V., Puzachenko, A. Yu. (2012): Species co-existence and morphological divergence in West Siberian mustelids (Carnivora, Mustelidae). – Mammal Study, 37: 255–259.  
<https://doi.org/10.3106/041.037.0310>
- Abramov, A. V., Puzachenko, A. Yu., Tumanov, I. L. (2016): Morphological differentiation of the skull in two closely-related mustelid species (Carnivora: Mustelidae). – Zoological Studies, 55: 1 (23 pp.).  
<https://doi.org/10.6620/ZS.2016.55-01>
- Abramov, A. V., Puzachenko, A. Yu., Wiig, Ø. (2009): Cranial variation in the European badger *Meles meles* (Carnivora, Mustelidae) in Scandinavia. – Zoological Journal of the Linnean Society, 157: 433–450.  
<https://doi.org/10.1111/j.1096-3642.2009.00507.x>
- Athen, K. (2006): Biostatistical investigation of long bones and metapodial bones of *Ursus spelaeus* and *Ursus deningeri*. – Scientific Annals, School of Geology Aristotle University of Thessaloniki (AUTH), Special volume 98: 159–162.
- Athen, K. (2007): Biometrische Untersuchungen des Stylopodiums, Zygopodiums und Metapodiums pleistozäner Ursiden im Hinblick auf die Evolution des Höhlenbären und die Klassifizierung des Fundmaterials Einhornhöhle/Harz; Dissertation. – MS, Geowissenschaftliche Fakultät der Eberhard-Karls-Universität Tübingen, Tübingen, Germany, 79 pp + Appendix. (copy available free on-line)
- Athen, K. (2009): Statistische Analyse an Metapodien des rezenten *Ursus arctos* zur Geschlechterdifferenzierung. – BioArchaeologica, 5: 35–44.
- Athen, K., Frömke, C., Germonpré, M. (2005): Analysis of postcranial elements of cave bear material (*Ursus spelaeus*) from Goyet (Candz/Belgium). – Bulletin de l’Institut royal des sciences naturelles de Belgique, Série Sciences de la terre, 75: 267–283.
- Athen, K., Pfitzschner, H.-U. (2005): Biometrical analysis of postcranial elements of fossil ursids from Einhornhöhle, Germany. – Abhandlung, Naturhistorische Gesellschaft Nürnberg e.V., 45: 35–42.
- Baca, M., Mackiewicz, P., Stankovic, A., Popović, D., Stefaniak, K., Czarnogórska, K., Nadachowski, A., Gąsiorowski M., Hercman, H., Węgleński, P. (2014): Ancient DNA and dating of cave bear remains from Niedźwiedzia Cave suggest early appearance of *Ursus ingressus* in Sudetes. – Quaternary International, 339–340: 217–223.  
<https://doi.org/10.1016/j.quaint.2013.08.033>
- Baca, M., Stankovic, A., Stefaniak, K., Marciszak, A., Hofreiter, M., Nadachowski, A., Węgleński, P., Mackiewicz, P. (2012): Genetic analyses of cave bear specimens from Niedźwiedzia Cave, Sudetes, Poland. – Palaeontologia Electronica, 15: 2.21A (16 pp.).
- Baryshnikov, G. (2006): Morphometrical variability of cheek teeth of cave bears. – Scientific Annals, School of Geology Aristotle University of Thessaloniki (AUTH), Special volume 98: 81–102.
- Baryshnikov, G. (2007): Semeystvo Medvezh’i (Carnivora, Ursidae) [Bears Family (Carnivora, Ursidae)] (Fauna Rossii i sopredel’nykh stran, N. S., no. 147 [Fauna of Russia and Neighboring Countries, N. S., no. 147]). – Nauka, St. Petersburg, 541 pp. (in Russian)
- Baryshnikov, G. F. (2012): Obzor iskopaeemykh ostatkov pozvonochnykh iz pleystotsenovykh sloev Akhshtyrskoy peshchery (Severo-zapadnyy Kavkaz) [A review of fossil vertebrate remains from Pleistocene layers of Akhshtyrskaya Cave (North-West Caucasus)]. – Proceedings of the Zoological Institute of the Russian Academy of Sciences, 316(2): 93–138. (in Russian with English summary)
- Baryshnikov, G. F., Batyrov, B. K. (1994): Srednepleystotsenovye khishchnye mlekopitayushchie (Carnivora, Mammalia) Sredney Azii [Middle Pleistocene carnivorous mammals (Carnivora, Mammalia) from Central Asia]. – Proceedings of Zoological Institute of the Russian Academy of Sciences, 256: 3–43. (in Russian with English summary)
- Baryshnikov, G., David, F. D. (2000): Les ours des cavernes à Arcy-sur-Cure (Yonne, France) – *Ursus (Spelearctos) spelaeus* Rosenmüller et Heinroth, 1794. – Quaternaire, 11(1): 65–79.  
<https://doi.org/10.3406/quate.2000.1656>
- Baryshnikov, G., Foronova, I. (2001): Pleistocene small cave bear (*Ursus rossicus*) from the South Siberia, Russia. – Cadernos Laboratorio Xeolóxico de Laxe, 26: 373–398.
- Baryshnikov, G. F., Germonpré, M., Sablin, M. (2003): Sexual dimorphism and morphometric variability of cheek teeth of the cave bear (*Ursus spelaeus*). – Belgian Journal of Zoology, 133(2): 111–119.
- Baryshnikov, G. F., Puzachenko, A. Yu. (2011): Craniometrical variability of cave bears (Carnivora, Ursidae). – Quaternary International, 245: 350–368.  
<https://doi.org/10.1016/j.quaint.2011.02.035>
- Baryshnikov, G. F., Puzachenko, A. Yu. (2012): Kraniometricheskaya izmenchivost’ rechnoy vydry (*Lutra lutra*: Carnivora: Mustelidae) v severnoy Evrazii [Cranio-metrical variability of the Eurasian otter (*Lutra lutra*: Carnivora: Mustelidae) from the Northern Eurasia]. – Proceedings of the Zoological Institute of the Russian

- Academy of Sciences, 316: 203–222. (in Russian, with English summary)
- Bassinot, F. C., Labeyrie, L. D., Vincent, E., Quidelleur, X., Shackleton, N. J., Lancelot, Y. (1994): The astronomical theory of climate and the age of the Brunhes-Matuyama magnetic reversal. – *Earth and Planetary Science Letters*, 126: 91–108.  
[https://doi.org/10.1016/0012-821X\(94\)90244-5](https://doi.org/10.1016/0012-821X(94)90244-5)
- Carlis, A. de, Alluvione, E., Fonte, A., Rossi, M., Santi, G. (2005): Morphometry of the *Ursus spelaeus* remains from Valstrona (northern Italy). – *Geo.Alp*, 2: 115–126.
- Churchill, S., Smith, F. H. (2000): Makers of the earliest Auriignacian of Europe. – *Yearbook of Physical Anthropology* (Hoboken), 43: 61–115.  
[https://doi.org/10.1002/1096-8644\(2000\)43:31+<61::AID-AJPA4>3.0.CO;2-3](https://doi.org/10.1002/1096-8644(2000)43:31+<61::AID-AJPA4>3.0.CO;2-3)
- Dabney, J., Knapp, M., Glocke, I., Gansauge, M.-T., Weihmann, A., Nickel, B., Valdiosera, C., García, N., Pääbo, S., Arsuaga, J.-L., Meyer, M. (2013): Complete mitochondrial genome sequence of a Middle Pleistocene cave bear reconstructed from ultrashort DNA fragments. – *Proceedings of the National Academy of Sciences of the United States of America*, 110(39): 15758–15763.  
<https://doi.org/10.1073/pnas.1314445110>
- Davison, M. L., Jones, L. E. (eds) (1983): Special issue: multidimensional scaling and its applications. – *Applied Psychological Measurement*, 7: 373–514.  
<https://doi.org/10.1177/014662168300700401>
- Dempster, A. P., Laird, N. M., Rubin, D. B. (1977): Maximum likelihood from incomplete data via the EM algorithm. – *Journal of the Royal Statistical Society, Series B*, 39: 1–38.
- Döppes, D., Kempe, S., Rosendahl, W. (2008): Dated palaeontological cave sites of Central Europe from late Middle Pleistocene to early Upper Pleistocene (OIS 5 to OIS 8). – *Quaternary International*, 187: 97–104.  
<https://doi.org/10.1016/j.quaint.2007.03.023>
- Döppes, D., Pacher, M., Rabeder, G., Lindauer, S., Freidrich, R., Kromer, B., Rosendahl, W. (2016): Unexpected! New AMS dating from Austrian cave bear sites. – *Cranium*, 33: 26–30.
- Falguères, C., Yokoyama, Y., Shen, G., Bischoff, J. L., Ku, T. L., de Lumley, H. (2004): New U-series dates at the Caune de l’Arago, France. – *Journal of Archaeological Science*, 31: 941–952.  
<https://doi.org/10.1016/j.jas.2003.12.008>
- Fejfar, O., Horáček, I. (1990): Review of fossil arvicolids (Mammalia, Rodentia) of the Pliocene and Quaternary in Czechoslovakia. – In: Fejfar, O., Heinrich, W.-D. (eds), *International Symposium Evolution, Phylogeny and Biostratigraphy of Arvicolids (Rodentia, Mammalia)*. Geological Survey, Prague, pp. 125–132.
- Fortes, G. G., Grandal-d’Anglade, A., Kolbe, B., Fernandes, D., Meleg, I. N., García-Vázquez, A., Pinto-Llona, A. C., Constantin, S., de Torres, T. J., Ortiz, J. E., Frischauf, C., Rabeder, G., Hofreiter, M., Barlow, A. (2016): Ancient DNA reveals differences in behaviour and sociality between brown bears and extinct cave bears. – *Molecular Ecology*, 25: 4907–4918.  
<https://doi.org/10.1111/mec.13800>
- García, N. G. (2003): Osos y otros carnívoros de la Sierra de Atapuerca [Bear and other predators from Sierra de Atapuerca]. – *Fundación Oso de Asturias, Oviedo*, 575 pp. (in Spanish)
- Grandal-d’Anglade, A. (1993): Sexual dimorphism and interpopulational variability in the lower carnassial of the cave bear, *Ursus spelaeus* Ros-Hein. – *Cadernos Laboratorio Xeolóxico de Laxe*, 18: 231–239.
- Grandal-d’Anglade, A. (2001): A review of the cave bear sex dimorphism. – *Cadernos Laboratorio Xeolóxico de Laxe*, 26: 399–405.
- Grandal-d’Anglade, A., López-González, F. (2004): A study of the evolution of the Pleistocene cave bear by morphometric analysis of the lower carnassial. – *Oryctos*, 5: 83–94.
- Grandal-d’Anglade, A., López-González, F. (2005): Sexual dimorphism and ontogenetic variation in the skull of the cave bear (*Ursus spelaeus* Rosenmüller) of the European Upper Pleistocene. – *Geobios*, 38: 325–337.  
<https://doi.org/10.1016/j.geobios.2003.12.001>
- Hammer, Ø., Harper, D. A. T., Ryan, P. D. (2001): PAST: Paleontological Statistics Software Package for Education and Data Analysis. – *Palaeontologia Electronica*, 4(1): 1–9.
- Higham, T. F. G., Jacobi, R. M., Ramsey, C. B. (2006): AMS radiocarbon dating of ancient bone using ultrafiltration. – *Radiocarbon*, 48(2): 179–195.  
<https://doi.org/10.1017/S0033822200066388>
- Hofreiter, M., Capelli, C., Krings, M., Waits, L., Conard, N., Münzel, S., Rabeder, G., Nagel, D., Paunović, M., Jambrešić, G., Meyer, S., Weiss, G., Pääbo, S. (2002): Ancient DNA Analyses Reveal High Mitochondrial DNA Sequence Diversity and Parallel Morphological Evolution of Late Pleistocene Cave Bears. – *Molecular Biology and Evolution*, 19(8): 1244–1250.  
<https://doi.org/10.1093/oxfordjournals.molbev.a004185>
- Jambrešić, G., Paunović, M. (2002): Osteometry, variability, biomechanics and locomotion pattern of the cave bear limb bones from Croatian localities. – *Geologia Croatica*, 55(1): 1–10.
- Kahlke, H.-D. (1961): Revision der Säugetierfaunen der klassischen deutschen Pleistozän-Fundstellen von Süßenborn, Mosbach und Taubach. – *Geologie*, 10(4/5): 493–532.
- Kahlke, H.-D. (1969): Das Pleistozän von Süßenborn. – *Paläontologische Abhandlungen, Abt. A*, 3(3/4): 367–788.
- Kahlke, R.-D., García, N., Kostopoulos, D. S., Lacombe, F., Lister, A. M., Mazza, P. P. A., Spassov, N., Titov, V. V. (2011): Western Palaearctic palaeoenvironmental conditions during the Early and early Middle Pleistocene inferred from large mammal communities, and implications for hominin dispersal in Europe. – *Quaternary Science Reviews*, 30: 1368–1395.  
<https://doi.org/10.1016/j.quascirev.2010.07.020>
- Keller, T. (1994): Die eiszeitlichen Mosbach-Sande bei Wiesbaden. Alt- und mittelpleistozäne Säugetierfunde aus Ablagerungen des Ur-Maines. – *Paläontologische Denkmäler in Hessen*, 3: 1–15.
- Kendall, M. G. (1975): *Rank Correlation Methods* (4th ed.). – Charles Griffin and Co., Ltd, London, 272 pp.

- Knapp, M., Rohland, N., Weinstock, J., Baryshnikov, G., Sher, A., Nagel, D., Rabeder, G., Pinhasi, R., Schmitt, H., Hoffreiter, M. (2009): First DNA sequences of Asian cave bear fossils reveal deep divergences and complex phylogeographic patterns. – *Molecular Ecology*, 18(6): 1225–1238.  
<https://doi.org/10.1111/j.1365-294X.2009.04088.x>
- Kosintsev, P. A., Gasilin, V. V., Gimranov, D. O., Bachura, O. P. (2016): Carnivores (Mammalia, Carnivora) of the Urals in the Late Pleistocene and Holocene. – *Quaternary International*, 420: 145–155.  
<https://doi.org/10.1016/j.quaint.2015.10.089>
- Krajcarz, M., Pacher, M., Krajcarz, M. T., Laughlan, L., Rabeder, G., Sabol, M., Wojtal, P., Bocherens, H. (2016): Isotopic variability of cave bears ( $\delta^{15}\text{N}$ ,  $\delta^{13}\text{C}$ ) across Europe during MIS 3. – *Quaternary Science Reviews*, 131: 51–72.  
<https://doi.org/10.1016/j.quascirev.2015.10.028>
- Krause, J., Unger, T., Noçon, A., Malaspinas, A.-S., Kolokotronis, S.-O., Stiller, M., Soibelzon, L., Spriggs, H., Dear, P. H., Briggs, A. W., Bray, S. C. E., O'Brien, S. J., Rabeder, G., Matheus, P., Cooper, A., Slatkin, M., Pääbo, S., Hofreiter, M. (2008): Mitochondrial genomes reveal an explosive radiation of extinct and extant bears near the Miocene-Pliocene boundary. – *BMC Evolutionary Biology*, 8: 220 (12 pp).  
<https://doi.org/10.1186/1471-2148-8-220>
- Kurtén, B. (1955): Sex dimorphism and size trends in the cave bear, *Ursus spelaeus* Rosenmüller and Heinroth. – *Acta Zoologica Fennica*, 90: 1–48.
- Kurtén, B. (1968): Pleistocene Mammals of Europe. – Weidenfeld and Nicolson, London, 317 pp.
- Loreille, O., Orlando, L., Patou-Mathis, M., Philippe, M., Taberlet, P., Hänni, C. (2001): Ancient DNA analysis reveals divergence of the cave bear, *Ursus spelaeus*, and brown bear, *Ursus arctos*, lineages. – *Current Biology*, 11(3): 200–203.  
[https://doi.org/10.1016/S0960-9822\(01\)00046-X](https://doi.org/10.1016/S0960-9822(01)00046-X)
- Leney, M. D. (2000): Bear Feet in the Pleistocene: Ecological heterogeneity in Croatian *Ursus* and its comparative and co-evolutionary implications. – *Wissenschaftliche Schriften des Neanderthal Museums*, 2: 54–67.
- Lumley, H. de, Fournier, A., Park, Y. C., Yokoyama, Y., Demouy, A. (1984): Stratigraphie du remplissage Pléistocène moyen de la caune de l'Arago à Tautavel. Etude de huit carottages effectués de 1981 à 1983. – *L'Anthropologie*, 88(1): 5–18.
- Lundberg, J., McFarlane, D. A. (2007): Pleistocene depositional history in a periglacial terrane: a 500 k.y. record from Kents Cavern, Devon, United Kingdom. – *Geosphere*, 3(4): 199–219.  
<https://doi.org/10.1130/GES00085.1>
- Lynch, J. M., Conroy, J. W. H., Kitchener, A. C., Jefferies, D. J., Hayden, T. J. (1996): Variation in cranial form and sexual dimorphism among five European populations of the otter *Lutra lutra*. – *Journal of Zoology*, 238(1): 81–96.  
<https://doi.org/10.1111/j.1469-7998.1996.tb05380.x>
- Mattson, D. J. (1998): Diet and morphology of extant and recently extinct northern bears. – *Ursus*, 10: 479–496.
- Maul, L. C., Rekovets, L., Heinrich, W., Keller, T., Storch, G. (2000): *Arvicola mosbachensis* (Schmidtgen 1911) of Mosbach 2: a basic sample for the early evolution of the genus and a reference for further biostratigraphical studies. – *Senckenbergiana lethaea*, 80(1): 129–147.  
<https://doi.org/10.1007/BF03043667>
- Mazza, P., Rustioni, M. (1992): Morphometric revision of the Eurasian species *Ursus etruscus* Cuvier. – *Palaeontographia Italica*, 79: 101–146.
- McFarlane, D. A., Sabol, M., Lundberg, J. (2011): A unique population of cave bears (Carnivora: Ursidae) from the Middle Pleistocene of Kents Cavern, England, based on dental morphometrics. – *Historical Biology*, 23: 131–137.  
<http://dx.doi.org/10.1080/08912963.2010.483730>
- Mlíkovský, J. (2009): Middle Pleistocene birds of Hundsheim, Austria. – *Journal of the National Museum (Prague), Natural History Series*, 177(7): 69–82.
- Moigne, A.-M., Palombo, M. R., Belda, V., Heriech-Briki, D., Kacimi, S., Lacombat, F., Lumley, M.-A. de, Moutoussamy, J., Rivals, F., Quilès, J., Testu, A. (2006): Les faunes de grands mammifères de la Caune de l'Arago (Tautavel) dans le cadre biochronologique des faunes du Pléistocène moyen italien. – *L'Anthropologie*, 110: 788–831.  
<https://doi.org/10.1016/j.anthro.2006.10.011>
- Monakhov, V. G. (2014): Size structure of the sable in the Lake Baikal Region: a decadal analysis over the last sixty years. – *Biology Bulletin*, 41(1): 47–54.  
<https://doi.org/10.1134/S1062359014010063>
- Münzel, S. C., Athen, K. (2009): Correlating genetic results with biometric analysis on metapodial bones. – *Slovenský kras/Acta Carsologica Slovaca*, 47(supplement 1): 47–56.
- Musil, R. (1966): Holštejn, eine neue altpleistozäne Lokalität in Mähren. – *Acta Musei Moraviae, Scientiae naturales*, 51: 133–168.
- Musil, R. (1974): Lažánky bei Tišnov – eine neue Fundstätte der Biharienfauna. – *Acta Musei Moraviae, Scientiae naturales*, 59: 87–93.
- Nagel, D., Pronin, K., Rabeder, G., Hofreiter, M., Huijjer, W., Kavcik, N., Urbanek, C., Withalm, G., Orlov, N. (2005): Nerubajskoe, a new cave bear site in the old Nordmann territory. – *Mitteilungen der Kommission für Quartärforschung der Österreichischen Akademie der Wissenschaften*, 14: 123–134.
- Nagel, D., Rabeder, G. (1997): Revision der mittelpleistozänen Großsäugerfauna aus Deutsch-Altenburg 1. – *Wissenschaftliche Mitteilungen aus dem Niederösterreichischen Landesmuseum*, 10: 231–249.
- Pacher, M., Stuart, A. J. (2009): Extinction chronology and palaeobiology of the cave bear (*Ursus spelaeus*). – *Boreas*, 38: 189–206.  
<https://doi.org/10.1111/j.1502-3885.2008.00071.x>
- Perrier, X., Flori, A., Bonnot, F. (2003): Data analysis methods. – In: Hamon, P., Seguin, M., Perrier, X., Glaszmann, J. C., (eds), *Genetic Diversity of Cultivated Tropical Plants*. Science Publishers, Montpellier, France, pp. 43–76.
- Petronio, C., Canzio, E., Stefano, G. (2003): Morphological and biometrical differences in the limb bones of *Ursus arctos* and *Ursus spelaeus* and phylogenetical considerations on the two species. – *Palaeontographica, Abt. A*, 269(4-6): 137–152.

- Pigott, T. D. (2001): A review of methods for missing data. – *Educational Research and Evaluation*, 7(4): 3533–383. <https://doi.org/10.1076/edre.7.4.353.8937>
- Powell, R. A., King, C. M. (1997): Variation in body size, sexual dimorphism and age-specific survival in stoats, *Mustela ermine* (Mammalia: Carnivora), with fluctuating food supplies. – *Biological Journal of the Linnean Society*, 62: 165–194. <https://doi.org/10.1111/j.1095-8312.1997.tb01621.x> <https://doi.org/10.1006/bijl.1996.0154>
- Puzachenko, Yu. G., Puzachenko, M. Yu., Kozlov, D. N., Aleshchenko, G. M. (2004). Soil structure analysis with the use of digital color images. – *Pochvovedeniye*, 2: 113–146. (in Russian)
- Rabeder, G. (1999). Die Evolution des Höhlenbären-Gebisses. – *Mitteilung der Kommission für Quartärforschung der Österreichischen Akademie der Wissenschaften*, 11: 1–102.
- Rabeder, G., Debeljak, I., Hofreiter, M., Withalm, G. (2008): Morphological responses of cave bears (*Ursus spelaeus* group) to high-alpine habitats. – *Die Höhle*, 59: 59–72.
- Rabeder, G., Pacher, M., Withalm, G. (2010): Early Pleistocene bear remains from Deutsch-Altenburg (Lower Austria). – *Mitteilungen der Kommission für Quartärforschung der Österreichischen Akademie der Wissenschaften*, 17: 1–135.
- Reichstein, H. (1957): Schädelvariabilität europäischer Mauswiesel (*Mustela nivalis* L.) und Hermeline (*Mustela erminea* L.) in Beziehung zu Verbreitung und Geschlecht. – *Zeitschrift für Säugetierkunde*, 22: 151–182.
- Robu, M. (2016): Age re-assessment of the cave bear assemblage from Urşilor Cave, north-western Romania. – *International Journal of Speleology*, 45(2): 123–133. <https://doi.org/10.5038/1827-806X.45.2.1947>
- Rosendahl, W., Döppes, D., Joger, U., Laskowski, R., López Correa, M., Nielbock, R., Wrede, V. (2005): New radiometric dating of different cave bear sites in Germany – results and interpretations. – *Bulletin de la Societe d'Histoire Naturelle de Toulouse*, 141: 39–46.
- Santi, G., Rossi, M. (2005): *Ursus spelaeus* from the Buco dell'Orso Cave (Laglio, Lombardy, north Italy): an evolutionary hypothesis. – *PalArch's Journal of Vertebrate Palaeontology*, 3(3): 20–29.
- Santi, G., Rossi, M. (2014): Metapodial bones of *Ursus gr. spelaeus* from selected caves of the North Italy. A biometrical study and evolutionary trend. – *Annales de Paleontologie*, 100: 237–256. <https://doi.org/10.1016/j.annpal.2014.01.003>
- Sattath, S., Tversky, A. (1977): Additive similarity trees. – *Psychometrika*, 42: 319–345. <https://doi.org/10.1007/BF02293654>
- Schmidt, M., Fischer, M. S. (2009): Morphological integration in mammalian limb proportions: dissociation between function and development. – *Evolution*, 63(3): 749–66. <https://doi.org/10.1111/j.1558-5646.2008.00583.x>
- Searle, S. R., Casella, G., McCulloch, C. E. (1992): Variance components. – Wiley, New York, 536 pp. <https://doi.org/10.1002/9780470316856>
- Sher, A. V., Weinstock, J., Baryshnikov, G. F., Davydov, S. P., Boeskorov, G. G., Zazhigin, V. S., Nikolsky, P. A. (2011): The first records of spelaeoid bears in Arctic Siberia. – *Quaternary Science Reviews*, 30(17-18): 2238–2249. <https://doi.org/10.1016/j.quascirev.2010.10.016>
- Stefansky, W. (1972): Rejecting outliers in factorial designs. – *Technometrics*, 14: 469–479. <https://doi.org/10.1080/00401706.1972.10488930>
- Stiller, M., Baryshnikov, G., Bocherens, H., Grandal d'Anglade, A., Hilpert, B., Münzel, S., Pinhasi, R., Rabeder, G., Rosendahl, W., Trinkaus, E., Hofreiter, M., Knapp, M. (2010): Withering Away – 25,000 years of genetic decline preceded cave bear extinction. – *Molecular Biology and Evolution*, 27(5): 975–978. <https://doi.org/10.1093/molbev/msq083>
- Stiller, M., Molak, M., Prost, S., Rabeder, G., Baryshnikov, G., Rosendahl, W., Münzel, S., Bocherens, H., Grandal-d'Anglade, A., Hilpert, B., Germonpré, M., Stasyk, O., Pinhasi, R., Tintori, A., Rohland, N., Mohandesan, E., Ho, S. Y. W., Hofreiter, M., Knapp, M. (2014): Mitochondrial DNA diversity and evolution of the Pleistocene cave bear complex. – *Quaternary International*, 339-340: 224–231. <https://doi.org/10.1016/j.quaint.2013.09.023>
- Toškan, B. (2006): Cave bear metapodials from Divje Babe I (Western Slovenia). – *Scientific Annals, School of Geology Aristotle University of Thessaloniki (AUTH)*, Special volume 98: 147–158.
- Toškan, B. (2007): Morphometric study of cave bear metapodials from Divje babe I. – In: Turk, I. (ed.), *Divje babe I. Upper Pleistocene Palaeolithic site in Slovenia. Part I: Geology and Palaeontology*. Opera Instituti archaeologici Sloveniae, 13: 397–433.
- Toškan, B., Bona F. (2012): Body size variability in cave bears from the Southern Alps. – In: De Grosse Mazzorin, J., Saccà, D., Tozzi, C. (eds), *Atti 6° Convegno Nazionale di Archeozoologia*. Associazione Italiana di Archeozoologia, Lecce, pp. 47–55.
- Tsoukala, E., Chatzopoulou, K., Rabeder, G., Pappa, S., Nagel, D., Withalm, G. (2006): Paleontological and stratigraphical research in Loutra Arideas Bear Cave (Almopia speleopark, Pella, Macedonia, Greece). *Scientific Annals, School of Geology Aristotle University of Thessaloniki (AUTH)*, Special volume 98: 41–67.
- Tsoukala, E., Grandal-d'Anglade, A. (2002): Système de mesures du squelette des Ursidés. – *Études et Recherches Archéologiques de l'Université de Liège (ERAUL)*, 100: 265–287.
- Valdiosera, C., García, N., Dalén, L., Smith, C., Kahlke, R.-D., Lidén, K., Angerbjörn, A., Arsuaga, J. L., Götherström, A. (2006): Typing single polymorphic nucleotides in mitochondrial DNA as a way to access middle Pleistocene DNA. – *Biology Letters*, 2: 601–603. <https://doi.org/10.1098/rsbl.2006.0515>
- Velichko, A. A., Arslanov, Kh. A., Gerasimova, S. A., Islamov, U. I., Kremenetski, K. V., Markova, A. K., Udartsev, V. P., Chikolini, N. I. (1991): Paleocology of the Acheulean cave site Sel-Ungur (Soviet Central Asia). – *Anthropologie*, 29(1-2): 9–15.
- Vereshchagin, N. K. (1973): Kraniologicheskaya kharakteristika sovremnykh i iskopaemykh medvedey [Cranio-metrical characteristic of recent and fossil bears]. – *Zoologi-*



- cheskiy zhurnal, 52(6): 920–930. (in Russian with English summary)
- Vishnyatsky, L. B. (1999): The Paleolithic of Central Asia. – *Journal of World Prehistory*, 13(1): 69–122. <https://doi.org/10.1023/A:1022538427684>
- Wagner, J. (2010): Pliocene to early Middle Pleistocene ursine bears in Europe: a taxonomic overview. – *Journal of the National Museum (Prague), Natural History Series*, 179(20): 197–215.
- Wagner, J., Čermák, S. (2012): Revision of the early Middle Pleistocene bears (Ursidae, Mammalia) of Central Europe, with special respect to possible co-occurrence of spelaeoid and arctoid lineages. – *Bulletin of Geosciences*, 87(3): 461–496. <https://doi.org/10.3140/bull.geosci.1354>
- Withalm, G. (2001): Die Evolution der Metapodien in der Höhlenbären-Gruppe (Ursidae, Mammalia). – *Beiträge zur Paläontologie*, 26: 169–249.
- Withalm, G. (2004): Analysis of the cave bear metapodial bones from Potočka zijalka (Slovenia). – *Mitteilungen der Kommission für Quartärforschung der Österreichischen Akademie der Wissenschaften*, 13: 149–160.
- Withalm, G. (2014): Analysis of the cave bear metapodial bones from Križna jama (Slovenia). – *Mitteilungen der Kommission für Quartärforschung der Österreichischen Akademie der Wissenschaften*, 21: 117–122.
- Yom-Tov, Y., Heggberget, T. M., Wiig, Ø., Yom-Tov, S. (2006): Body size changes among otters, *Lutra lutra*, in Norway: the possible effects of food availability and global warming. – *Oecologia*, 150(1): 155–60. <https://doi.org/10.1007/s00442-006-0499-8>
- Yom-Tov, Y., Yom-Tov, S., Baagøe, H. J. (2003): Increase of skull size in the red fox (*Vulpes vulpes*) and Eurasian badger (*Meles meles*) in Denmark during the twentieth century: an effect of improved diet?. – *Evolutionary Ecology Research*, 5: 1037–1048.
- Yom-Tov, Y., Yom-Tov, S., MacDonald, D., Yom-Tov, E. (2007): Population cycles and changes in body size of the lynx in Alaska. – *Oecologia*, 152(2): 239–244. <https://doi.org/10.1007/s00442-006-0653-3>
- Yom-Tov, Y., Yom-Tov, S., Zachos, F. E. (2013): Temporal and geographical variation in skull size of the red fox (*Vulpes vulpes*) and the Eurasian badger (*Meles meles*) in Austria. – *Biological Journal of the Linnean Society*, 108: 579–585. <https://doi.org/10.1111/j.1095-8312.2012.02028.x>
- Zyll de Jong, C. G. van (1992): A morphometric analysis of cranial variation in Holarctic weasels (*Mustela nivalis*). – *Zeitschrift für Säugetierkunde*, 57: 77–93.

## **Supplement I**

### **Additional materials to**

**Gennady F. Baryshnikov, Andrei Yu. Puzachenko**

### **Morphometrical analysis of metacarpal and metatarsal bones of cave bears (Carnivorarsidae)**

#### **Content**

METACARPAL BONE I (mtc I) .....	8
Males and females.....	8
Sexual size dimorphism.....	8
Univariate analysis .....	10
Multivariate analyses.....	14
Males .....	16
Females.....	18
METACARPAL BONE II (mtc II) .....	20
Males and females.....	20
Sexual dimorphism.....	20
Univariate statistic.....	22
Multivariate analysis .....	27
Males .....	29
Females.....	31
METACARPAL BONE III (mtc III).....	33
Males and females.....	33
Sexual dimorphism.....	33
Univariate analysis .....	35
Multivariate analysis .....	39
Males .....	41
Females.....	43
METACARPAL BONE IV (mtc IV) .....	45
Males and females.....	45
Sexual dimorphism.....	45
Univariate analysis .....	47
Multivariate analysis .....	51
Males .....	53
Females.....	55
METACARPAL BONE V (mtc V).....	57
Males and females.....	57

Sexual size dimorphism.....	57
Univariate analysis.....	59
Multivariate analyses.....	63
Males.....	65
Females.....	67

## List of Figures

Fig. S1. The scatterplots of measures (GL – Dd) of mtc I and their UPMGA classification: et – <i>U. etruscus</i> , a – <i>U. arctos</i> , r – <i>U. rossicus</i> , d – <i>U. deningeri</i> , pk – <i>U. k. praekudarensis</i> , ku – <i>U. k. kudarensis</i> , s – <i>U. s. spelaeus</i> , k – <i>U. k. kanivetz</i> , i – <i>U. k. ingressus</i> , e – <i>U. s. eremus</i> , l – <i>U. s. ladinicus</i> . .....	10
Fig. S2. The scatterplot of Index plumpness (ip) and GL of mtc I: et – <i>U. etruscus</i> , a – <i>U. arctos</i> , r – <i>U. rossicus</i> , sa – <i>U. savini</i> , d – <i>U. deningeri</i> , pk – <i>U. k. praekudarensis</i> , ku – <i>U. k. kudarensis</i> , s – <i>U. s. spelaeus</i> , k – <i>U. k. kanivetz</i> , i – <i>U. k. ingressus</i> , e – <i>U. s. eremus</i> , l – <i>U. s. ladinicus</i> . Point – males, square – females.....	12
Fig. S3. Scatterplot of the first dimensions of “size” (E1) and “shape” (K1) morphospaces reproduced variation of mtc I in males and females: A, C – models with <i>U. arctos</i> ; B – model without <i>U. arctos</i> ; C – “size” morphospace; D – NJ tree; E – UGMA dendrogram (cophenetic correlation – 0.92); F – Sattath-Tversky (Sattath, Tversky, 1977) additive tree. All classifications based on the coordinates of samples’ centroids in the “size” (E1, E2) and “shape” (K1, K2) morphospaces (numbers near the nodes - bootstrap (1000 repeats) supports in %). Ellipses’ horizontal and vertical projection onto the E1 (E2) and K1 axes are equal to the “sample mean” (centroid) ± “sample range” x 0.95.....	15
Fig. S4. Scatterplot of the first dimensions of “size” (E1) and “shape” (K1) morphospaces reproduced variation of mtc I in males: A, C – models with <i>U. arctos</i> ; B – model without <i>U. arctos</i> ; C – “size” morphospace; D – NJ tree; E – UGMA dendrogram (cophenetic correlation – 0.92); F – Sattath-Tversky (Sattath, Tversky, 1977) additive tree. All classifications based on the coordinates of samples’ centroids in the “size” (E1, E2) and “shape” (K1, K2) morphospaces (numbers near the nodes - bootstrap (1000 repeats) supports in %). Ellipses’ horizontal and vertical projection onto the E1 (E2) and K1 axes are equal to the “sample mean” (centroid) ± “sample range” x 0.95.....	17
Fig. S5. Scatterplot of the first dimensions of “size” (E1) and “shape” (K1) morphospaces reproduced variation of mtc I in females: A, C – models with <i>U. arctos</i> ; B – model without <i>U. arctos</i> ; C – “size” morphospace; D – NJ tree; E – UGMA dendrogram (cophenetic correlation – 0.95); F – Sattath-Tversky (Sattath, Tversky, 1977) additive tree. All classifications based on the coordinates of samples’ centroids in the “size” (E1, E2) and “shape” (K1, K2) morphospaces (numbers near the nodes - bootstrap (1000 repeats) supports in %). Ellipses’ horizontal and vertical projection onto the E1 (E2) and K1 axes are equal to the “sample mean” (centroid) ± “sample range” x 0.95.....	19
Fig. S6. The scatterplots of length of mtc II and the other measures (BP – DD) and relationships between measures of mtc II (single linkage, correlation distances used): et – <i>U. etruscus</i> , a – <i>U. arctos</i> , r – <i>U. rossicus</i> , d – <i>U. deningeri</i> , pk – <i>U. k. praekudarensis</i> , ku – <i>U. k. kudarensis</i> , s – <i>U. s. spelaeus</i> , k – <i>U. k. kanivetz</i> , i – <i>U. k. ingressus</i> , e – <i>U. s. eremus</i> , l – <i>U. s. ladinicus</i> . The dashed lines are lines of regressions and ellipses’ horizontal and vertical projections onto the axes are equal to the “sample mean ± “sample range” x 0.95.....	24
Fig. S7. The scatterplot of Index plumpness (ip) and GL of mtc II: a – <i>U. arctos</i> , r – <i>U. rossicus</i> , d – <i>U. deningeri</i> , pk – <i>U. k. praekudarensis</i> , ku – <i>U. k. kudarensis</i> , s – <i>U. s. spelaeus</i> , k – <i>U. k. kanivetz</i> , i – <i>U. k. kanivetz</i> , e – <i>U. s. eremus</i> , l – <i>U. s. ladinicus</i> . Point – males, square – females. ....	26

- Fig. S8. Scatterplot of the first dimensions of “size” (E1) and “shape” (K1) morphospaces reproduced variation of mtc II in males and females: A, C – models with *U. arctos*; B – model without *U. arctos*; C – “size” morphospace; D – NJ tree; E – UGMA dendrogram (cophenetic correlation – 0.89); F – Sattath-Tversky (Sattath, Tversky, 1977) additive tree. All classifications based on the coordinates of samples’ centroids in the “size” (E1, E2) and “shape” (K1, K2) morphospaces (numbers near the nodes - bootstrap (1000 repeats) supports in %). Ellipses’ horizontal and vertical projection onto the E1 (E2) and K1 axes are equal to the “sample mean” (centroid)  $\pm$  “sample range”  $\times$  0.95.....28
- Fig. S9. Scatterplot of the first dimensions of “size” (E1) and “shape” (K1) morphospaces reproduced variation of mtc II in males: A, C – models with *U. arctos*; B – model without *U. arctos*; C – “size” morphospace; D – NJ tree; E – UGMA dendrogram (cophenetic correlation – 0.88); F – Sattath-Tversky (Sattath, Tversky, 1977) additive tree. All classifications based on the coordinates of samples’ centroids in the “size” (E1, E2) and “shape” (K1, K2) morphospaces (numbers near the nodes - bootstrap (1000 repeats) supports in %). Ellipses’ horizontal and vertical projection onto the E1 (E2) and K1 axes are equal to the “sample mean” (centroid)  $\pm$  “sample range”  $\times$  0.95.....30
- Fig. S10. Scatterplot of the first dimensions of “size” (E1) and “shape” (K1) morphospaces reproduced variation of mtc II in females A, C – models with *U. arctos*; B – model without *U. arctos*; C – “size” morphospace; D – NJ tree; E – UGMA dendrogram (cophenetic correlation – 0.92); F – Sattath-Tversky (Sattath, Tversky, 1977) additive tree. All classifications based on the coordinates of samples’ centroids in the “size” (E1, E2) and “shape” (K1, K2) morphospaces (numbers near the nodes - bootstrap (1000 repeats) supports in %). Ellipses’ horizontal and vertical projection onto the E1 (E2) and K1 axes are equal to the “sample mean”(centroid)  $\pm$  “sample range”  $\times$  0.95.....32
- Fig. S11. The scatterplots of length of mtc III and the other measures (Bp – Dd) and Relationships between measures of mtc II (single linkage, correlation distances used): et – *U. etruscus*, a – *U. arctos*, r – *U. rossicus*, d – *U. deningeri*, pk – *U. k. praekudarensis*, ku – *U. k. kudarensis*, s – *U. s. spelaeus*, k – *U. k. kanivetz*, i – *U. k. ingressus*, e – *U. s. eremus*, l – *U. s. ladinicus*. The dashed lines are lines of regressions and ellipses’ horizontal and vertical projections onto the axes are equal to the “sample mean  $\pm$  “sample range”  $\times$  0.95. ....37
- Fig. S12. The scatterplot of Index plumpness (ip) and GL of mtc III: a – *U. arctos*, r – *U. rossicus*, sa – *U. savini*, d – *U. deningeri*, pk – *U. k. praekudarensis*, ku – *U. k. kudarensis*, s – *U. s. spelaeus*, k – *U. k. kanivetz*, i – *U. k. ingressus*, e – *U. s. eremus*, l – *U. s. ladinicus*. Point – males, square – females.....39
- Fig. S13. Scatterplot of the first dimensions of “size” (E1) and “shape” (K1) morphospaces reproduced variation of mtc III in males and females: A, C – models with *U. arctos*; B – model without *U. arctos*; C – “size” morphospace; D – NJ tree; E – UGMA dendrogram (cophenetic correlation – 0.92); F – Sattath-Tversky (Sattath, Tversky, 1977) additive tree. All classifications based on the coordinates of samples’ centroids in the “size” (E1, E2) and “shape” (K1, K2) morphospaces (numbers near the nodes - bootstrap (1000 repeats) supports in %). Ellipses’ horizontal and vertical projection onto the E1 (E2) and K1 axes are equal to the “sample mean” (centroid)  $\pm$  “sample range”  $\times$  0.95. ....40
- Fig. S14. Scatterplot of the first dimensions of “size” (E1) and “shape” (K1) morphospaces reproduced variation of mtc III in males: A, C – models with *U. arctos*; B – model without *U. arctos*; C – “size” morphospace; C – “size” morphospace; D – NJ tree; E – UGMA dendrogram (cophenetic correlation – 0.92); F – Sattath-Tversky (Sattath, Tversky, 1977) additive tree. All classifications based on the coordinates of samples’ centroids in the “size” (E1, E2) and “shape” (K1, K2) morphospaces (numbers near the nodes - bootstrap (1000 repeats) supports in %). Ellipses’ horizontal and vertical projection onto the E1 (E2) and K1 axes are equal to the “sample mean” (centroid)  $\pm$  “sample range”  $\times$  0.95. ....42
- Fig. S15. Scatterplot of the first dimensions of “size” (E1) and “shape” (K1) morphospaces reproduced variation of mtc III in females: A, C – models with *U. arctos*; B – model without *U.*

- arctos*; C – “size” morphospace; D – NJ tree; E – UGMA dendrogram (cophenetic correlation – 0.92); F – Sattath-Tversky (Sattath, Tversky, 1977) additive tree. All classifications based on the coordinates of samples’ centroids in the “size” (E1, E2) and “shape” (K1, K2) morphospaces (numbers near the nodes - bootstrap (1000 repeats) supports in %). Ellipses’ horizontal and vertical projection onto the E1 (E2) and K1 axes are equal to the “sample mean” (centroid)  $\pm$  “sample range”  $\times$  0.95. ....44
- Fig. S16. The scatterplots of length of mtc IV and the other measures (BP – DD) and Relationships between measures of mtc IV (single linkage, correlation distances used): et – *U. etruscus*, a – *U. arctos*, r – *U. rossicus*, d – *U. deningeri*, pk – *U. k. praekudarensis*, ku – *U. k. kudarensis*, s – *U. s. spelaeus*, k – *U. k. kanivetz*, i – *U. k. ingressus*, e – *U. s. eremus*, l – *U. s. ladinicus*. The dashed lines are lines of regressions and ellipses’ horizontal and vertical projections onto the axes are equal to the “sample mean  $\pm$  “sample range”  $\times$  0.95 .....49
- Fig. S17. The scatterplot of Index plumpness (ip) and GL of mtc IV: a – *U. arctos*, r – *U. rossicus*, d – *U. deningeri*, pk – *U. k. praekudarensis*, ku – *U. k. kudarensis*, s – *U. s. spelaeus*, k – *U. k. kanivetz*, i – *U. k. ingressus*, e – *U. s. eremus*, l – *U. s. ladinicus*. Points – males, squares – females.....51
- Fig. S18. Scatterplot of the first dimensions of “size” (E1) and “shape” (K1) morphospaces reproduced variation of mtc IV in males and females: A, C – models with *U. arctos*; B – model without *U. arctos*; C – “size” morphospace; D – NJ tree; E – UGMA dendrogram (cophenetic correlation – 0.86); F – Sattath-Tversky (Sattath, Tversky, 1977) additive tree. All classifications based on the coordinates of samples’ centroids in the “size” (E1, E2) and “shape” (K1, K2) morphospaces (numbers near the nodes - bootstrap (1000 repeats) supports in %). Ellipses’ horizontal and vertical projection onto the E1 (E2) and K1 axes are equal to the “sample mean” (centroid)  $\pm$  “sample range”  $\times$  0.95.....52
- Fig. S19. Scatterplot of the first dimensions of “size” (E1) and “shape” (K1) morphospaces reproduced variation of mtc IV in males: A, C – models with *U. arctos*; B – model without *U. arctos*; C – “size” morphospace; D – NJ tree; E – UGMA dendrogram (cophenetic correlation – 0.93); F – Sattath-Tversky (Sattath, Tversky, 1977) additive tree. All classifications based on the coordinates of samples’ centroids in the “size” (E1, E2) and “shape” (K1, K2) morphospaces (numbers near the nodes - bootstrap (1000 repeats) supports in %). Ellipses’ horizontal and vertical projection onto the E1 (E2) and K1 axes are equal to the “sample mean” (centroid)  $\pm$  “sample range”  $\times$  0.95. ....54
- Fig. S20. Scatterplot of the first dimensions of “size” (E1) and “shape” (K1) morphospaces reproduced variation of mtc IV in females: A, C – models with *U. arctos*; B – model without *U. arctos*; C – “size” morphospace; D – NJ tree; E – UGMA dendrogram (cophenetic correlation – 0.81); F – Sattath-Tversky (Sattath, Tversky, 1977) additive tree. All classifications based on the coordinates of samples’ centroids in the “size” (E1, E2) and “shape” (K1, K2) morphospaces (numbers near the nodes - bootstrap (1000 repeats) supports in %). Ellipses’ horizontal and vertical projection onto the E1 (E2) and K1 axes are equal to the “sample mean” (centroid)  $\pm$  “sample range”  $\times$  0.95. ....56
- Fig. S21. The scatterplots of measures (GL – Dd) of mtc V and their classification: et – *U. etruscus*, a – *U. arctos*, r – *U. rossicus*, d – *U. deningeri*, pk – *U. k. praekudarensis*, ku – *U. k. kudarensis*, s – *U. s. spelaeus*, k – *U. k. kanivetz*, i – *U. k. ingressus*, e – *U. s. eremus*, l – *U. s. ladinicus*. ....59
- Fig. S22. Scatterplot of Index plumpness (ip) and GL of mtc V: et – *U. etruscus*, a – *U. arctos*, r – *U. rossicus*, d – *U. deningeri*, pk – *U. k. praekudarensis*, ku – *U. k. kudarensis*, s – *U. s. spelaeus*, k – *U. k. kanivetz*, k – *U. k. ingressus*, e – *U. s. eremus*, l – *U. s. ladinicus*. Points – males, squares – females. ....62
- Fig. S23. Scatterplot of the first dimensions of “size” (E1) and “shape” (K1) morphospaces reproduced variation of mtc V in males and females: A, C – models with *U. arctos*; B – model without *U. arctos*; C – “size” morphospace; D – NJ tree; E – UGMA dendrogram (cophenetic correlation – 0.94); F – Sattath-Tversky (Sattath, Tversky, 1977) additive tree. All classifications

- based on the coordinates of samples' centroids in the "size" (E1, E2) and "shape" (K1, K2) morphospaces (numbers near the nodes - bootstrap (1000 repeats) supports in %). Ellipses' horizontal and vertical projection onto the E1 (E2) and K1 axes are equal to the "sample mean"  $\pm$  ("sample range"  $\times$  0.95). .....64
- Fig. S24. Scatterplot of the first dimensions of "size" and "shape" morphospaces reproduced variation of mtc V in males: A, C – models with *U. arctos*; B – model without *U. arctos*; C – "size" morphospace; D – NJ tree; E – UGMA dendrogram (cophenetic correlation – 0.88); F – Sattath-Tversky (Sattath, Tversky, 1977) additive tree. All classifications based on the coordinates of samples' centroids in the "size" and "shape" morphospaces (numbers near the nodes - bootstrap (1000 repeats) supports in %). Ellipses' horizontal and vertical projections onto the axes are equal to the "sample mean" (centroid)  $\pm$  "highest value - "  $\times$  0.95. ....66
- Fig. S25. Scatterplot of the first dimensions of "size" and "shape" morphospaces reproduced variation of mtc V in females: A, C – models with *U. arctos*; B – model without *U. arctos*; C – "size" morphospace; D – NJ tree; E – UGMA dendrogram (cophenetic correlation – 0.95); F – Sattath-Tversky (Sattath, Tversky, 1977) additive tree. All classifications based on the coordinates of samples' centroids in the "size" and "shape" morphospaces (numbers near the nodes - bootstrap (1000 repeats) supports in %). Ellipses' horizontal and vertical projections onto the axes are equal to the "sample mean" (centroid)  $\pm$  "sample range"  $\times$  0.95. ....68

## List of Tables

Table S1. Sample numbers (N), means (M), and standard errors (m) of the variables of mtc I among different forms of bears .....	8
Table S2. Sexual size dimorphism (SSD and ASSD) of mtc I in the different forms of cave bears and brown bear; <i>p</i> based on Mann-Whitney U Test; <i>v</i> , % - relative variance associated with SSD. ....	8
Table S3. Statistical parameters of measures of mtc I among different bears and sexes: m – males, f – females. ....	11
Table S4. Kruskal-Wallis test <i>z'</i> values (males - above diagonal and females – under diagonal) for measures of mtc I. The statistical significance values, according to 2-tailed <i>p</i> values, have been underlined.....	12
Table S5. Description of the modeled morphological spaces for cave bears and brown bear mtc I. Correlation coefficients among the measures and dimensions of two morphospace models (MDS axes: E1–E3, K1–K3); $r^2$ – coefficients of determination in the linear multiple regression models. ....	14
Table S6. Description of the modeled morphological spaces of mtc I for males of cave bears and brown bear. Correlation coefficients among the measures and dimensions of two morphospace models (MDS axes: E1–E2, K1–K2); $r^2$ – coefficients of determination in the linear multiple regression models. ....	16
Table S7. Description of the modeled morphological spaces of mtc I for females of cave bears and brown bear. Correlation coefficients among the measures and dimensions of two morphospace models (MDS axes: E1–E2, K1–K2); $r^2$ – coefficients of determination in the linear multiple regression models. ....	18
Table S8. Sample numbers (N), means (M), and standard errors (m) of the variables of mtc II among different forms of bears .....	20
Table S9. Sexual size dimorphism (SSD and ASSD) of mtc II in the different forms of cave bears and brown bear ; <i>p</i> based on Mann-Whitney U Test; <i>v</i> , % - relative variance associated with SSD. ....	20
Table S10. Kruskal-Wallis test <i>z'</i> values (males - above diagonal and females – under diagonal) for measures of mtc II. The statistical significance values, according to 2-tailed <i>p</i> values, have been underlined.....	22

Table S11. Statistical parameters of measures of mtc II among different bears and sexes: m – males, f – females. ....	25
Table S12. Description of the modeled morphological spaces for cave bears and brown bear mtc II. Correlation coefficients among the measures and dimensions of two morphospace models (MDS axes: E1–E2, K1–K2); $r^2$ – coefficients of determination in the linear multiple regression models. ....	27
Table S13. Description of the modeled morphological spaces for males of cave bears and brown bear mtc II. Correlation coefficients among the measures and dimensions of two morphospace models (MDS axes: E1–E2, K1–K2); $r^2$ – coefficients of determination in the linear multiple regression models. ....	29
Table S14. Description of the modeled morphological spaces for females of cave bears and brown bear mtc II. Correlation coefficients among the measures and dimensions of two morphospace models (MDS axes: E1–E2, K1–K2); $r^2$ – coefficients of determination in the linear multiple regression models. ....	31
Table S15. Sample numbers (N), means (M), and standard errors (m) of the variables of mtc III among different forms of bears ....	33
Table S16. Sexual size dimorphism (SSD and ASSD) of mtc III in the different forms of cave bears and brown bear ; $p$ based on Mann-Whitney U Test; $v$ , % - relative variance associated with SSD. ....	33
Table S17. Kruskal-Wallis test $z'$ values (males - above diagonal and females – under diagonal) for measures of mtc III. The statistical significance values, according to 2-tailed $p$ values, have been underlined. ....	35
Table S18. Statistical parameters of measures of mtc III among different bears and sexes: m – males, f – females. ....	38
Table S19. Description of the modeled morphological spaces for cave bears and brown bear mtc III. Correlation coefficients among the measures and dimensions of two morphospace models (MDS axes: E1–E2, K1–K2); $r^2$ – coefficients of determination in the linear multiple regression models. ....	39
Table S20. Description of the modeled morphological spaces for males of cave bears and brown bear mtc III. Correlation coefficients among the measures and dimensions of two morphospace models (MDS axes: E1–E2, K1–K2); $r^2$ – coefficients of determination in the linear multiple regression models. ....	41
Table S21. Description of the modeled morphological spaces for females of cave bears and brown bear mtc III. Correlation coefficients among the measures and dimensions of two morphospace models (MDS axes: E1–E2, K1–K2); $r^2$ – coefficients of determination in the linear multiple regression models. ....	43
Table S22. Sample numbers (N), means (M), and standard errors (m) of the variables of mtc IV among the different forms of bears ....	45
Table S23. Sexual size dimorphism (SSD and ASSD) of mtc IV in the different forms of cave bears and brown bear; $p$ based on Mann-Whitney U Test; $v$ , % - relative variance associated with SSD. ....	45
Table S24. Kruskal-Wallis test $z'$ values (males - above diagonal and females – under diagonal) for measures of mtc IV. The statistical significance values, according to 2-tailed $p$ values, have been underlined. ....	47
Table 26. Description of the modeled morphological spaces for cave bears and brown bear mtc IV. Correlation coefficients among the measures and dimensions of two morphospace models (MDS axes: E1–E2, K1–K2); $r^2$ – coefficients of determination in the linear multiple regression models. ....	51
Table S27. Description of the modeled morphological spaces for males of cave bears and brown bear mtc IV. Correlation coefficients among the measures and dimensions of two morphospace models (MDS axes: E1–E2, K1–K2); $r^2$ – coefficients of determination in the linear multiple regression models. ....	53

Table S28. Description of the modeled morphological spaces for females of cave bears and brown bear mtc IV. Correlation coefficients among the measures and dimensions of two morphospace models (MDS axes: E1–E2, K1–K2); $r^2$ – coefficients of determination in the linear multiple regression models. ....	55
Table S29. Sample numbers (N), means (M), and standard errors (m) of the variables of mtc V among different forms of bears .....	57
Table S30. Sexual size dimorphism ( <i>SSD</i> and <i>ASSD</i> ) of mtc V in the different forms of cave bears and brown bear; <i>p</i> based on Mann-Whitney U Test; v, % - relative variance associated with <i>SSD</i> . ....	57
Table S31. Statistical parameters of measures of mtc V among different bears and sexes: m – males, f – females. ....	60
Table S32. Kruskal-Wallis test <i>z'</i> values (males - above diagonal and females – under diagonal) for GL and BP of mtc V between bear taxa. The statistical significance values, according to 2-tailed <i>p</i> values, have been underlined. ....	61
Table S33. Description of the modeled morphological spaces for cave bears and brown bear mtc V. Correlation coefficients among the measures and dimensions of two morphospace models (MDS axes: E1–E2, K1–K2); $r^2$ – coefficients of determination in the linear multiple regression models. ....	63
Table S34. Description of the modeled morphological spaces for males of cave bears and brown bear mtc V. Correlation coefficients among the measures and dimensions of two morphospace models (MDS axes: E1–E2, K1–K2); $r^2$ – coefficients of determination in the linear multiple regression models. ....	65
Table S35. Description of the modeled morphological spaces for females of cave bears and brown bear mtc V. Correlation coefficients among the measures and dimensions of two morphospace models (MDS axes: E1–E2, K1–K2); $r^2$ – coefficients of determination in the linear multiple regression models. ....	67



**METACARPAL BONE I (MTC I)****Males and females**

Table S1. Sample numbers (N), means (M), and standard errors (m) of the variables of mtc I among different forms of bears

Form	GL		Bp		Dp		SD	
	N	M±m	N	M±m	N	M±m	N	M±m
<i>U. etruscus</i>	1	54.2		no data		no data	1	8.7
<i>U. deningeri</i>	48	62.8±0.71	48	24.2±0.30	48	21.5±0.30	48	12.2±0.18
<i>U. k. praekudarensis</i>	12	69.4±1.96	13	26.7±0.92	13	21.6±0.84	14	13.4±0.46
<i>U. k. kudarensis</i>	61	69.7±0.40	65	28.8±0.28	64	26.5±0.32	63	14.6±0.15
<i>U. savini</i>	1	53.9	1	22.00	1	16.8	1	11.5
<i>U. rossicus</i>	11	50.0±0.92	7	18.6±0.25	7	16.1±0.41	7	9.8±0.20
<i>U. s. spelaeus</i>	7	59.6±0.83	7	22.8±0.29	6	21.1±0.53	7	11.8±0.18
<i>U. k. kanivetz</i>	23	62.4±0.87	24	24.2±0.59	24	22.0±0.63	24	12.6±0.35
<i>U. s. eremus</i>	20	63.2±1.01	20	24.5±0.60	20	22.0±0.61	20	12.6±0.30
<i>U. s. ladinicus</i>	10	62.0±1.54	10	23.7±1.00	10	21.5±0.72	10	13.0±0.56
<i>U. k. ingressus</i>	54	66.0±0.54	21	25.1±0.57	21	21.6±0.71	54	13.0±0.16
<i>U. arctos</i>	25	73.0±1.96	26	22.4±0.79	21	21.4±0.79	26	10.7±0.36
			Bd		Dd			
			N	M±m	N	M±m		
<i>U. etruscus</i>			1	13.5	1	11.4		
<i>U. deningeri</i>			47	18.4±0.24	44	16.6±0.18		
<i>U. k. praekudarensis</i>			14	20.5±0.72	14	18.2±0.54		
<i>U. k. kudarensis</i>			61	21.8±0.21	55	18.7±0.14		
<i>U. savini</i>			1	17.2	1	15.1		
<i>U. rossicus</i>			11	14.9±0.32	7	13.0±0.19		
<i>U. s. spelaeus</i>			7	17.6±0.33	5	16.8±0.65		
<i>U. k. kanivetz</i>			23	18.8±0.36	21	17.2±0.39		
<i>U. s. eremus</i>			20	18.4±0.33	20	18.1±0.29		
<i>U. s. ladinicus</i>			10	18.6±0.64	10	17.4±0.47		
<i>U. k. ingressus</i>			51	19.2±0.23	39	18.5±0.25		
<i>U. arctos</i>			25	17.7±0.58	20	15.6±0.55		

**Sexual size dimorphism**Table S2. Sexual size dimorphism (SSD and ASSD) of mtc I in the different forms of cave bears and brown bear; *p* based on Mann-Whitney U Test; *v*, % - relative variance associated with SSD.

	SSD						ASSD
	GL	Bp	Dp	SD	Bd	Dd	
	<i>U. deningeri</i>						
Males	67.9±0.83	26.5±0.34	23.0±0.47	13.3±0.22	20.3±0.22	17.8±0.21	
Females	60.2±0.57	23.1±0.24	20.8±0.31	11.6±0.18	17.5±0.17	15.9±0.13	
SSD	6.0±0.79	6.9±0.83	4.9±1.3	6.6±1.14	7.5±0.75	5.7±0.75	
	(<0.001)	(<0.001)	(<0.001)	(<0.001)	(<0.001)	(<0.001)	6.28
<i>v</i> , %	77.6	78.7	40.4	59.0	85.1	77.4	
	<i>U. rossicus</i>						
Males	53.8±1.83				15.0±0.58		
Females	48.6±0.48	18.6±0.25	16.14±0.41	9.8±0.20	14.9±0.41	12.9±0.19	
SSD	5.1±1.85	no data	no data	no data	0.5±2.37	no data	
	(0.01)				n.s.		-

	SSD						ASSD
	GL	Bp	Dp	SD	Bd	Dd	
v, %	-	-	-	-	-	-	
<i>U. k. praekudarensis</i>							
Males	72.6±0.92	28.5±0.44	23.4±0.58	14.3±0.31	22.0±0.38	19.3±0.24	
Females	60.6±1.14	22.6±0.58	18.7±0.84	11.6±0.48	17.0±0.63	15.6±0.56	
SSD	9.0±1.1 (0.009)	11.6±1.4 (0.003)	11.2±2.4 (0.003)	10.6±2.2 (0.002)	12.8±1.9 (0.002)	10.5±1.8 (0.002)	10.97
v, %	93.3	89.8	81.3	85.8	88.9	91.6	
<i>U. k. kudarensis</i>							
Males	70.5±0.40	29.7±0.22	27.2±0.32	14.9±0.15	22.2±0.18	18.9±0.11	
Females	66.6±0.50	26.0±0.54	24.3±0.57	13.4±0.22	19.9±0.43	17.8±0.35	
SSD	2.9±0.47 (<0.001)	6.6±1.04 (<0.001)	5.8±1.3 (<0.001)	5.4±0.95 (<0.001)	5.5±1.10 (<0.001)	3.0±0.99 (0.005)	4.86
v, %	53.5	71.3	45.7	50.1	55.0	37.2	
<i>U. s. spelaeus</i>							
Males	61.4±0.73	22.3±0.60	22.5±0.55	11.9±0.37	16.9±0.50	14.4	
Females	58.3±0.90	23.1±0.16	20.4±0.44	11.8±0.18	18.1±0.26	17.4±0.33	
SSD	2.5±0.97 (0.05)		5.1±1.32 n.s.	0.9±1.75 n.s.			-
v, %	-	-	-	-	-	-	
<i>U. s. ladinicus</i>							
Males	68.0±1.15	27.6±1.59	24.5±0.60	14.9±1.20	21.0±1.11	19.1±0.80	
Females	59.5±1.15	22.1±0.49	20.2±0.33	12.1±0.24	17.5±0.34	16.6±0.29	
SSD	6.6±1.3 (0.02)	11.1±3.4 (0.02)	9.7±1.5 (0.02)	10.4±4.5 (0.04)	8.9±3.0 (0.04)	6.9±2.4 (0.04)	8.96
v, %	81.0	82.3	91.5	72.5	78.1	75.6	
<i>U. s. eremus</i>							
Males	66.8±0.85	26.7±0.52	24.3±0.35	13.8±0.21	19.5±0.31	19.1±0.21	
Females	59.6±0.84	22.2±0.30	19.7±0.50	11.5±0.22	17.3±0.30	17.0±0.24	
SSD	5.7±0.94 (<0.001)	9.3±1.2 (<0.001)	10.5±1.4 (<0.001)	9.0±1.2 (<0.001)	5.9±1.2 (<0.001)	6.0±0.90 (<0.001)	7.74
v, %	78.1	85.3	85.1	84.8	70.5	81.3	
<i>U. k. kanivetz</i>							
Males	69.2±0.54	27.5±0.24	24.4±0.42	13.9±0.14	20.6±0.17	19.7±0.17	
Females	63.0±0.42	32.1±0.24	19.7±0.40	12.0±0.13	17.9±0.17	17.0±0.13	
SSD	4.7±0.52 (<0.001)	8.6±0.67 (<0.001)	10.7±1.34 (0.005)	7.3±0.74 (<0.001)	6.8±0.62 (<0.001)	7.3±0.58 (<0.001)	7.56
v, %	85.2	85.3	62.6	82.9	86.5	86.2	
<i>U. k. kanivetz</i>							
Males	66.4±1.21	27.1±0.67	25.0±0.71	14.1±0.49	20.4±0.37	18.4±0.32	
Females	60.0±0.49	22.2±0.23	19.8±0.32	11.5±0.18	17.6±0.23	16.3±0.27	
SSD	5.1±1.04 (<0.001)	9.9±1.5 (<0.001)	11.6±1.8 (<0.001)	10.2±2.04 (<0.001)	7.2±1.2 (<0.001)	6.3±1.7 (0.002)	8.38
v, %	66.5	84.1	84.3	74.4	78.8	59.3	
<i>U. arctos</i>							
Males	81.9±1.91	26.1±0.94	23.7±0.70	12.5±0.40	20.5±0.60	17.7±0.43	
Females	67.0±1.59	19.7±0.50	19.3±0.73	9.5±0.25	15.7±0.32	14.0±0.26	
SSD	10.1±1.7 (<0.001)	14.0±2.4 (<0.001)	10.2±2.4 (0.004)	13.5±2.2 (<0.001)	13.4±1.9 (<0.001)	11.7±1.6 (<0.001)	12.13

Univariate analysis

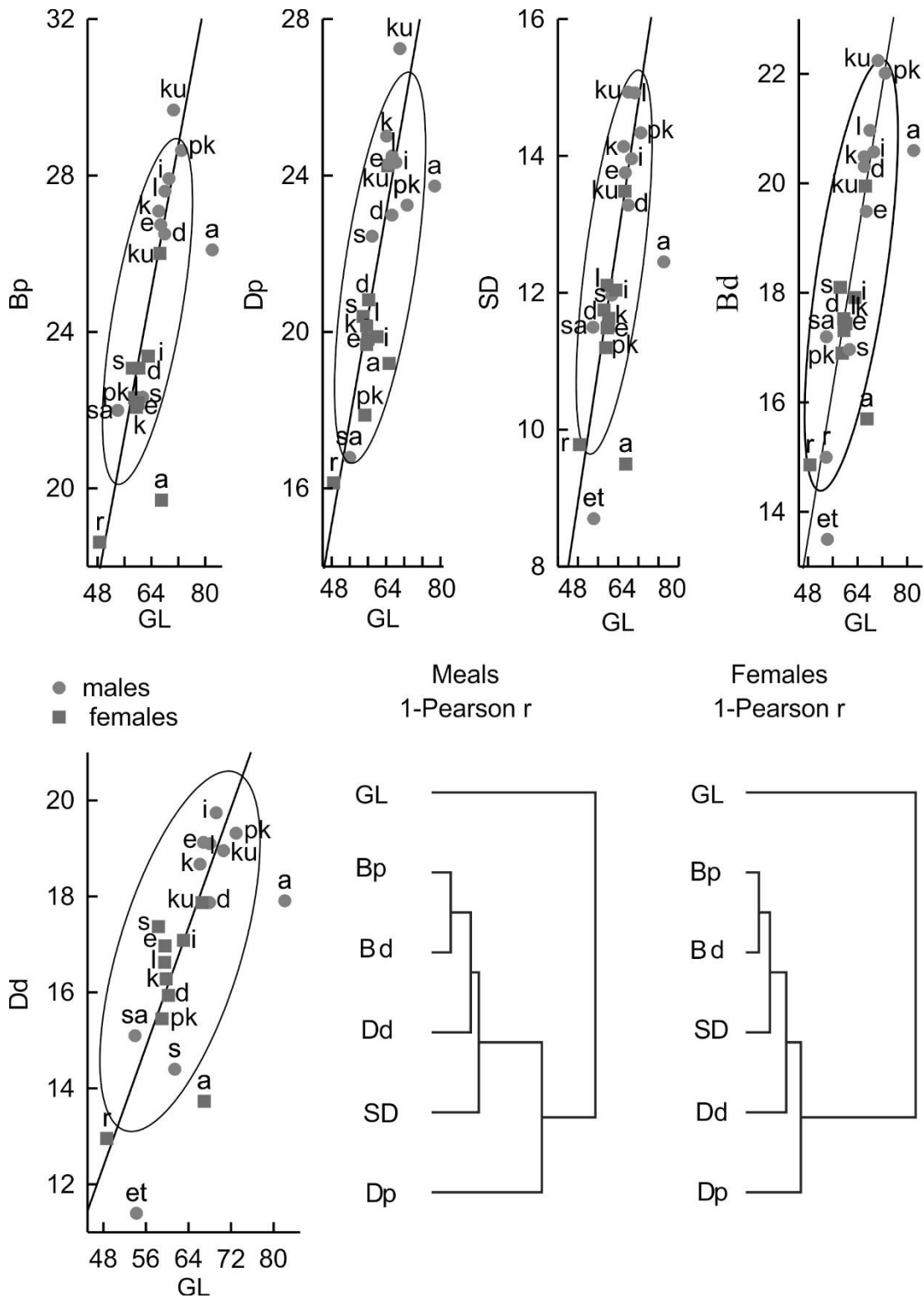

Fig. S1. The scatterplots of measures (GL – Dd) of mtc I and their UPMGA classification: et – *U. etruscus*, a – *U. arctos*, r – *U. rossicus*, d – *U. deningeri*, pk – *U. k. praekudarensis*, ku – *U. k. kudarensis*, s – *U. s. spelaeus*, k – *U. k. kanivetz*, i – *U. k. ingressus*, e – *U. s. eremus*, l – *U. s. ladinicus*.

Table S3. Statistical parameters of measures of mtc I among different bears and sexes: m – males, f – females.

Taxa	Sex	GL - N	GL	Std.Dev.	BP - N	BP	Std.Dev.	Dp- N	Dp	Std.Dev.	SD - N	SD	Std.Dev.	Bd - N	Bd	Std.Dev.	Dd- N	Dd	Std.Dev.
<i>U. etruscus</i>	m	1	54.2								1	8.7		1	13.5		1	11.4	
<i>U. savini</i>	m	1	53.9		1	22.0	0.00	1	16.8	0.00	1	11.5		1	17.2		1	15.1	
<i>U. rossicus</i>	f	8	48.6	1.36	7	18.6	0.67	7	16.1	1.08	7	9.8	0.52	8	14.9	1.16	7	13.0	0.50
	m	3	53.8	3.18										3	15.0	1.00			
<i>U. deningeri</i>	f	32	60.2	3.22	32	23.1	1.34	32	20.8	1.75	32	11.6	1.00	31	17.4	0.95	29	15.9	0.76
	m	16	67.9	3.33	16	26.5	1.35	16	23.0	1.88	16	13.3	0.88	16	20.3	0.90	15	17.9	0.87
<i>U. k. praekudar.</i>	f	3	59.0	1.17	4	22.3	1.37	4	17.9	0.78	4	11.2	0.71	4	16.9	1.61	4	15.5	1.35
	m	9	72.9	2.86	9	28.6	1.40	9	23.2	1.88	10	14.3	0.99	10	22.0	1.20	10	19.3	0.77
<i>U. k. kudarensis</i>	f	13	66.5	2.05	15	26.0	2.08	15	24.3	2.21	14	13.5	0.82	13	20.0	1.68	12	17.9	1.42
	m	48	70.6	2.85	50	29.7	1.52	49	27.2	2.30	49	14.9	1.07	48	22.2	1.26	43	19.0	0.79
<i>U. s. spelaeus</i>	f	4	58.3	1.80	4	23.1	0.32	4	20.4	0.88	4	11.8	0.37	4	18.1	0.54	4	17.4	0.67
	m	3	61.4	1.27	3	22.3	1.04	2	22.5	0.78	3	12.0	0.64	3	17.0	0.87	1	14.4	0.00
<i>U. k. kanivetz</i>	f	14	60.0	1.84	14	22.2	0.85	14	19.8	1.20	14	11.5	0.66	14	17.6	0.87	13	16.3	1.06
	m	9	66.1	3.99	10	27.1	2.13	10	25.0	2.25	10	14.1	1.55	9	20.5	1.18	8	18.7	1.76
<i>U. s. eremus</i>	f	10	59.6	2.64	10	22.2	0.93	10	19.7	1.57	10	11.5	0.70	10	17.3	0.96	10	17.0	0.77
	m	10	66.8	2.67	10	26.7	1.63	10	24.3	1.10	10	13.8	0.65	10	19.5	1.00	10	19.1	0.67
<i>U. s. ladinicus</i>	f	7	59.5	3.05	7	22.1	1.29	7	20.2	0.88	7	12.1	0.64	7	17.5	0.91	7	16.6	0.76
	m	3	68.0	1.99	3	27.6	2.75	3	24.5	1.04	3	14.9	2.07	3	21.0	1.93	3	19.1	1.39
<i>U. k. ingressus</i>	f	28	63.0	2.22	13	23.4	1.48	13	19.9	2.47	28	12.0	0.67	27	17.9	0.91	18	17.1	0.73
	m	26	69.2	2.85	8	27.9	1.00	8	24.3	2.38	26	14.0	0.74	24	20.6	0.93	21	19.7	0.90
<i>U. k. kanivetz</i>	f	14	60.0	1.84	14	22.2	0.85	14	19.8	1.20	14	11.5	0.66	14	17.6	0.87	13	16.3	1.06
	m	9	66.1	3.99	10	27.1	2.13	10	25.0	2.25	10	14.1	1.55	9	20.5	1.18	8	18.7	1.76
<i>U. arctos</i>	f	15	67.0	6.15	15	19.7	1.93	11	19.2	3.20	15	9.5	0.96	15	15.7	1.26	11	13.7	0.94
	m	10	82.1	6.66	11	26.1	3.12	10	23.7	2.43	11	12.5	1.31	10	20.6	2.07	9	17.9	1.55

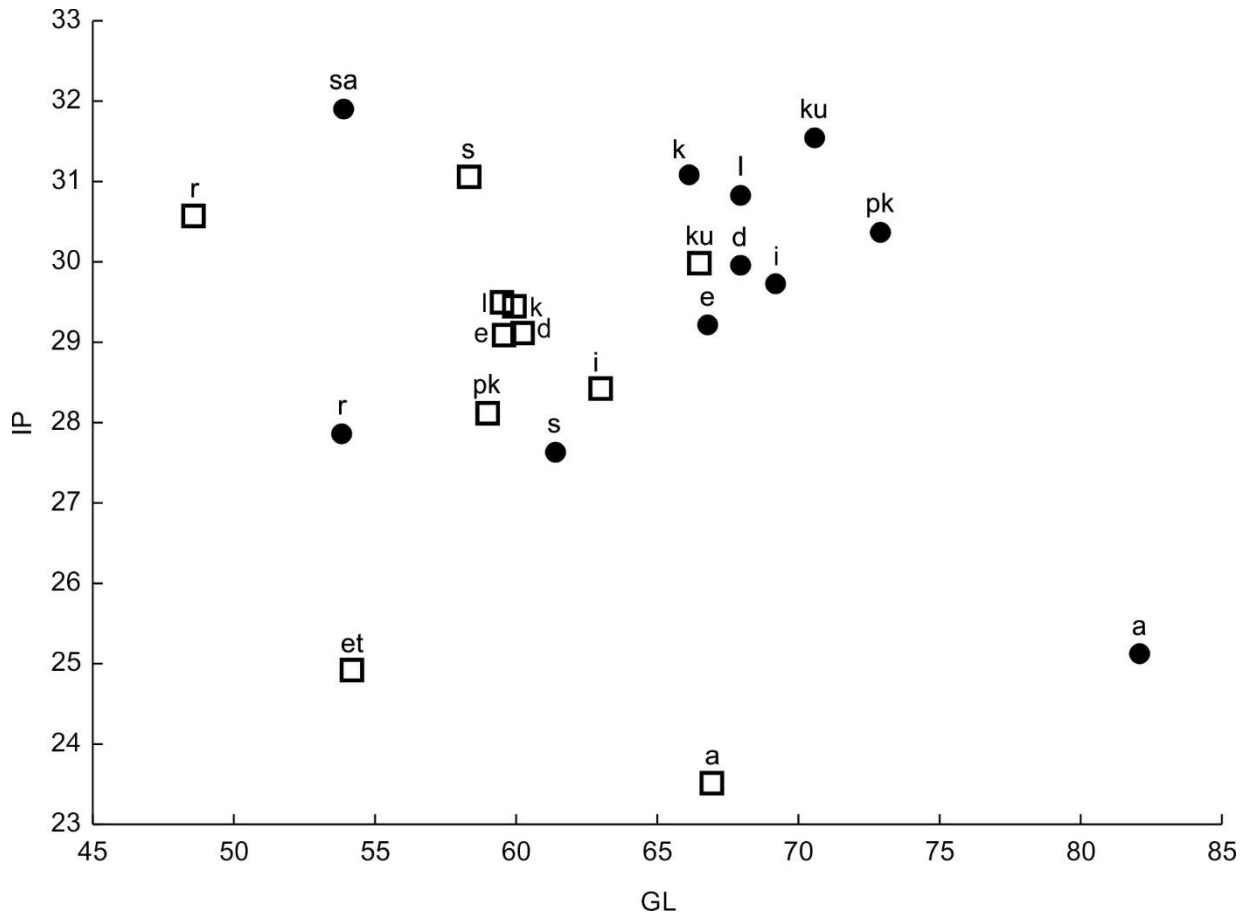

Fig. S2. The scatterplot of Index plumpness (ip) and GL of mtc I: et – *U. etruscus*, a – *U. arctos*, r – *U. rossicus*, sa – *U. savini*, d – *U. deningeri*, pk – *U. k. praekudarensis*, ku – *U. k. kudarensis*, s – *U. s. spelaeus*, k – *U. k. kanivetz*, i – *U. k. ingressus*, e – *U. s. eremus*, l – *U. s. ladinicus*. Point – males, square – females

Table S4. Kruskal-Wallis test z' values (males - above diagonal and females – under diagonal) for measures of mtc I. The statistical significance values, according to 2-tailed *p* values, have been underlined.

Taxa	1	2	3	4	5	6	7	8	9	10	
	GL										
<i>U. deningeri</i>	1	1.75	1.90	<u>4.65</u>	3.01	<u>4.79</u>	1.44	0.73	0.74	2.93	
<i>U. rossicus</i>	2	2.35		2.84	<u>5.23</u>	<u>3.97</u>	<u>5.36</u>	2.69	1.94	0.41	<u>4.00</u>
<i>U. k. praekudarensis</i>	3	0.05	1.01		0.12	0.32	0.30	0.85	1.12	2.01	0.30
<i>U. k. kudarensis</i>	4	<u>3.32</u>	<u>4.69</u>	1.05		0.35	0.49	1.70	1.89	2.89	0.91
<i>U. s. spelaeus</i>	5	2.20	<u>3.62</u>	0.95	0.10		0.10	1.48	1.72	2.64	0.86
<i>U. k. ingressus</i>	6	<u>5.00</u>	<u>5.90</u>	1.47	1.20	0.94		1.94	2.09	3.03	1.23
<i>U. k. kanivetz</i>	7	2.26	<u>3.90</u>	0.70	0.97	0.61	2.25		0.42	1.58	0.90
<i>U. s. eremus</i>	8	1.78	<u>3.56</u>	0.53	1.46	0.95	2.82	0.48		1.13	1.22
<i>U. s. ladinicus</i>	9	0.41	1.12	0.26	2.19	1.84	2.93	1.62	1.35		2.31
<i>U. arctos</i>	10	0.68	2.74	0.17	2.47	1.68	<u>3.91</u>	1.48	1.02	0.76	
	Bp										
<i>U. deningeri</i>	1		1.93	2.13	<u>4.69</u>	1.67	<u>4.67</u>	2.92	1.20	0.59	1.30
<i>U. rossicus</i>	2	1.99		3.26	<u>5.53</u>	2.92	<u>5.60</u>	<u>4.12</u>	2.50	0.67	0.80
<i>U. k. praekudarensis</i>	3	0.05	0.95		0.18	0.49	0.77	0.10	0.85	2.02	2.89
<i>U. k. kudarensis</i>	4	<u>3.81</u>	<u>5.08</u>	1.78		0.92	1.18	0.09	1.43	2.76	<u>5.81</u>
<i>U. s. spelaeus</i>	5	2.19	<u>3.33</u>	1.43	0.18		1.49	0.69	0.38	1.66	2.51
<i>U. k. ingressus</i>	6	<u>3.50</u>	<u>4.77</u>	1.76	0.03	0.19		0.85	1.95	3.13	<u>5.65</u>

Taxa		1	2	3	4	5	6	7	8	9	10
<i>U. k. kanivetz</i>	7	2.98	<u>4.36</u>	1.45	0.63	0.24	0.61		1.11	2.37	<u>3.84</u>
<i>U. s. eremus</i>	8	2.81	<u>4.24</u>	1.33	0.93	0.42	0.89	0.27		1.33	2.05
<i>U. s. ladinicus</i>	9	1.05	2.16	0.75	1.03	0.72	1.02	0.64	0.49		0.15
<i>U. arctos</i>	10	2.62	0.30	1.14	<u>6.01</u>	<u>3.72</u>	<u>5.56</u>	<u>5.16</u>	<u>5.08</u>		2.44
Dp											
<i>U. deningeri</i>	1		1.61	2.87	<u>4.29</u>	2.01	<u>4.74</u>	<u>3.58</u>	1.81	0.03	1.24
<i>U. rossicus</i>	2	2.22		<u>3.69</u>	<u>4.61</u>	2.97	<u>5.12</u>	<u>4.29</u>	2.76	1.00	0.59
<i>U. k. praekudarensis</i>	3	0.00	1.10		0.48	0.70	0.56	0.31	0.72	1.92	<u>3.65</u>
<i>U. k. kudarensis</i>	4	2.87	<u>4.53</u>	1.27		0.46	1.67	0.99	0.49	1.95	<u>5.28</u>
<i>U. s. spelaeus</i>	5	1.39	2.84	0.83	0.49		1.40	1.05	0.06	1.36	2.83
<i>U. k. ingressus</i>	6	<u>3.41</u>	<u>4.89</u>	1.67	0.86	1.08		0.23	1.37	2.59	<u>5.60</u>
<i>U. k. kanivetz</i>	7	2.23	<u>3.95</u>	1.03	0.47	0.16	1.25		1.06	2.26	<u>4.39</u>
<i>U. s. eremus</i>	8	2.60	<u>4.27</u>	1.18	0.17	0.37	0.99	0.30		1.27	2.58
<i>U. s. ladinicus</i>	9	0.52	1.79	0.35	1.00	0.51	1.47	0.72	0.90		0.66
<i>U. arctos</i>	10	2.75	0.54	1.41	<u>4.97</u>	3.23	<u>5.30</u>	<u>4.40</u>	<u>4.72</u>		2.14
SD											
<i>U. deningeri</i>	1		1.94	0.77	<u>3.58</u>	<u>3.40</u>	<u>5.43</u>	2.67	0.37	0.79	1.78
<i>U. rossicus</i>	2	2.05		2.24	<u>4.69</u>	<u>4.43</u>	<u>6.04</u>	<u>3.89</u>	1.76	0.48	0.50
<i>U. k. praekudarensis</i>	3	1.14	0.04		1.52	2.34	2.91	1.52	0.26	1.21	2.08
<i>U. k. kudarensis</i>	4	2.40	<u>3.88</u>	2.18		1.63	2.78	0.46	1.64	2.43	<u>5.49</u>
<i>U. s. spelaeus</i>	5	2.13	<u>3.36</u>	2.28	0.54		0.35	1.03	2.41	3.01	<u>4.51</u>
<i>U. k. ingressus</i>	6	<u>3.38</u>	<u>4.66</u>	2.55	0.79	0.04		1.06	2.84	<u>3.38</u>	<u>7.13</u>
<i>U. k. kanivetz</i>	7	2.79	<u>4.16</u>	2.39	0.50	0.18	0.23		1.65	2.39	<u>3.99</u>
<i>U. s. eremus</i>	8	0.80	2.57	1.48	1.45	1.53	2.28	1.87		0.93	1.54
<i>U. s. ladinicus</i>	9	0.50	1.68	1.26	0.76	1.03	1.19	1.03	0.06		0.18
<i>U. arctos</i>	10	<u>3.67</u>	1.01	0.52	<u>5.71</u>	<u>4.46</u>	<u>6.75</u>	<u>5.93</u>	<u>4.14</u>		2.45
Bd											
<i>U. deningeri</i>	1		1.71	1.18	<u>4.36</u>	1.90	<u>4.92</u>	<u>3.27</u>	0.20	0.39	1.74
<i>U. rossicus</i>	2	2.63		2.24	<u>4.97</u>	2.98	<u>5.42</u>	<u>4.20</u>	1.44	0.70	0.30
<i>U. k. praekudarensis</i>	3	0.30	0.78		1.01	0.37	1.43	1.19	0.82	1.17	2.22
<i>U. k. kudarensis</i>	4	1.35	<u>3.46</u>	0.76		0.65	1.04	0.53	2.29	2.39	<u>6.14</u>
<i>U. s. spelaeus</i>	5	0.89	2.61	0.71	0.02		1.16	0.90	1.31	1.61	3.09
<i>U. k. ingressus</i>	6	2.78	<u>4.59</u>	1.16	1.12	0.72		0.07	2.73	2.74	<u>6.61</u>
<i>U. k. kanivetz</i>	7	1.86	<u>3.86</u>	0.92	0.43	0.27	0.68		2.24	2.40	<u>4.54</u>
<i>U. s. eremus</i>	8	0.62	2.96	0.50	0.71	0.49	1.95	1.16		0.47	1.35
<i>U. s. ladinicus</i>	9	0.07	1.73	0.31	0.67	0.58	1.35	0.94	0.26		0.55
<i>U. arctos</i>	10	<u>4.02</u>	0.46	1.01	<u>4.84</u>	<u>3.28</u>	<u>6.48</u>	<u>5.38</u>	<u>4.29</u>		2.22
Dd											
<i>U. deningeri</i>	1		1.67	1.20	<u>4.84</u>	1.91	<u>5.18</u>	2.05	0.47	0.58	0.73
<i>U. rossicus</i>	2	2.18		2.24	<u>4.58</u>	2.70	<u>4.89</u>	2.98	1.64	0.65	1.12
<i>U. k. praekudarensis</i>	3	0.12	1.01		1.26	0.88	1.63	0.39	0.57	1.34	1.62
<i>U. k. kudarensis</i>	4	<u>3.86</u>	<u>4.93</u>	1.22		0.15	0.91	1.01	2.03	2.82	<u>5.16</u>
<i>U. s. spelaeus</i>	5	2.39	<u>3.60</u>	1.05	0.16		0.15	0.64	1.34	1.95	2.22
<i>U. k. ingressus</i>	6	3.21	<u>4.42</u>	1.09	0.27	0.04		1.48	2.38	3.12	<u>5.49</u>
<i>U. k. kanivetz</i>	7	2.23	<u>3.71</u>	0.64	1.52	0.90	1.13		1.03	1.84	2.51
<i>U. s. eremus</i>	8	2.82	<u>4.16</u>	0.80	1.14	0.62	0.77	0.44		0.81	0.91
<i>U. s. ladinicus</i>	9	0.86	2.14	0.35	1.34	1.01	1.12	0.40	0.67		0.17
<i>U. arctos</i>	10	1.42	0.77	0.65	<u>4.45</u>	3.11	<u>3.91</u>	3.12	<u>3.60</u>		1.64

**Multivariate analyses**

Table S5. Description of the modeled morphological spaces for cave bears and brown bear mtc  
 I. Correlation coefficients among the measures and dimensions of two morphospace models  
 (MDS axes: E1–E3, K1–K3);  $r^2$  – coefficients of determination in the linear multiple regression  
 models.

Measures	Morphospaces with <i>U. arctos</i>						Morphospaces without <i>U. arctos</i>					
	“Size” morphospace			“Shape” morphospace			$r^2$	“Size” morpho- space		“Shape” morphospace		$r^2$
	E1	E2	E3	K1	K2	K3		E1	K1	K2		
GL	0.73	0.62	0.26	-0.18	0.20	-0.38	0.95	0.89	0.06	0.38	0.86	
Bp	0.97	-0.02	0.01	0.09	-0.42	-0.58	0.98	0.97	-0.07	0.27	0.95	
Dp	0.88	0.13	-0.40	-0.30	-0.50	-0.35	0.99	0.88	-0.44	0.24	0.92	
SD	0.94	-0.24	0.03	0.24	-0.51	-0.29	0.96	0.94	-0.04	-0.02	0.94	
Bd	0.96	0.04	0.13	0.16	-0.29	-0.49	0.95	0.96	0.04	0.15	0.93	
Dd	0.92	-0.10	0.25	0.18	-0.27	-0.35	0.92	0.90	0.02	0.13	0.83	
Relative variance (%) of dimensions associated with taxonomical composition												
	50.4	62.5	24.8	28.5	50.5	15.8		56.1	4.5	14.2		

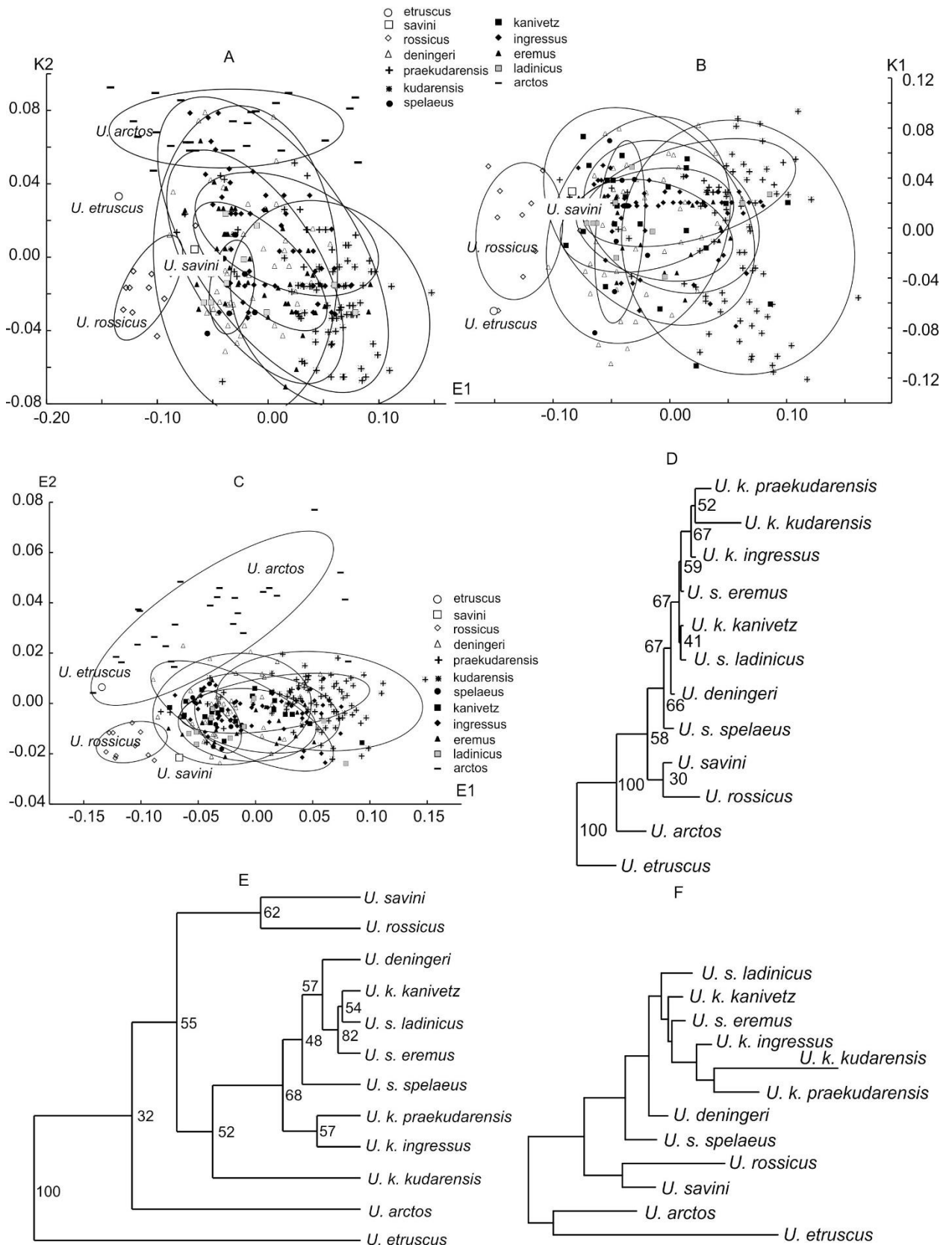

Fig. S3. Scatterplot of the first dimensions of “size” (E1) and “shape” (K1) morphospaces reproduced variation of mtc I in males and females: A, C – models with *U. arctos*; B – model without *U. arctos*; C – “size” morphospace; D – NJ tree; E – UGMA dendrogram (cophenetic correlation – 0.92); F – Sattath-Tversky (Sattath, Tversky, 1977) additive tree. All classifications based on the coordinates of samples’ centroids in the “size” (E1, E2) and “shape” (K1, K2) morphospaces (numbers near the nodes - bootstrap (1000 repeats) supports in %). Ellipses’



horizontal and vertical projection onto the E1 (E2) and K1 axes are equal to the “sample mean” (centroid)  $\pm$  “sample range”  $\times$  0.95.

## Males

Table S6. Description of the modeled morphological spaces of mtc I for males of cave bears and brown bear. Correlation coefficients among the measures and dimensions of two morphospace models (MDS axes: E1–E2, K1–K2);  $r^2$  – coefficients of determination in the linear multiple regression models.

Measures	Morphospaces with <i>U. arctos</i>					Morphospaces without <i>U. arctos</i>				
	“Size”		“Shape”		$r^2$	“Size”		“Shape”		$r^2$
	morphospace	morphospace	morphospace	morphospace		morphospace	morphospace			
E1	E2	K1	K2	E1	E2	K1	K2			
GL	0.61	0.41	0.22	0.05	0.80	0.67	-0.47	0.45	0.14	0.92
Bp	0.92	-0.07	0.03	-0.26	0.86	0.91	0.09	-0.20	-0.00	0.85
Dp	0.76	-0.70	-0.28	-0.70	0.88	0.74	0.68	-0.48	0.46	0.95
SD	0.89	-0.09	-0.32	-0.03	0.89	0.88	0.12	-0.30	-0.27	0.91
Bd	0.88	0.10	0.22	-0.06	0.90	0.88	-0.04	-0.05	-0.06	0.86
Dd	0.74	0.15	-0.02	0.06	0.67	0.74	-0.13	0.06	-0.02	0.62
Relative variance (%) of dimensions associated with taxonomical composition										
	70.2	56.3	63.6	19.3		76.9	26.6	18.4	7.5	

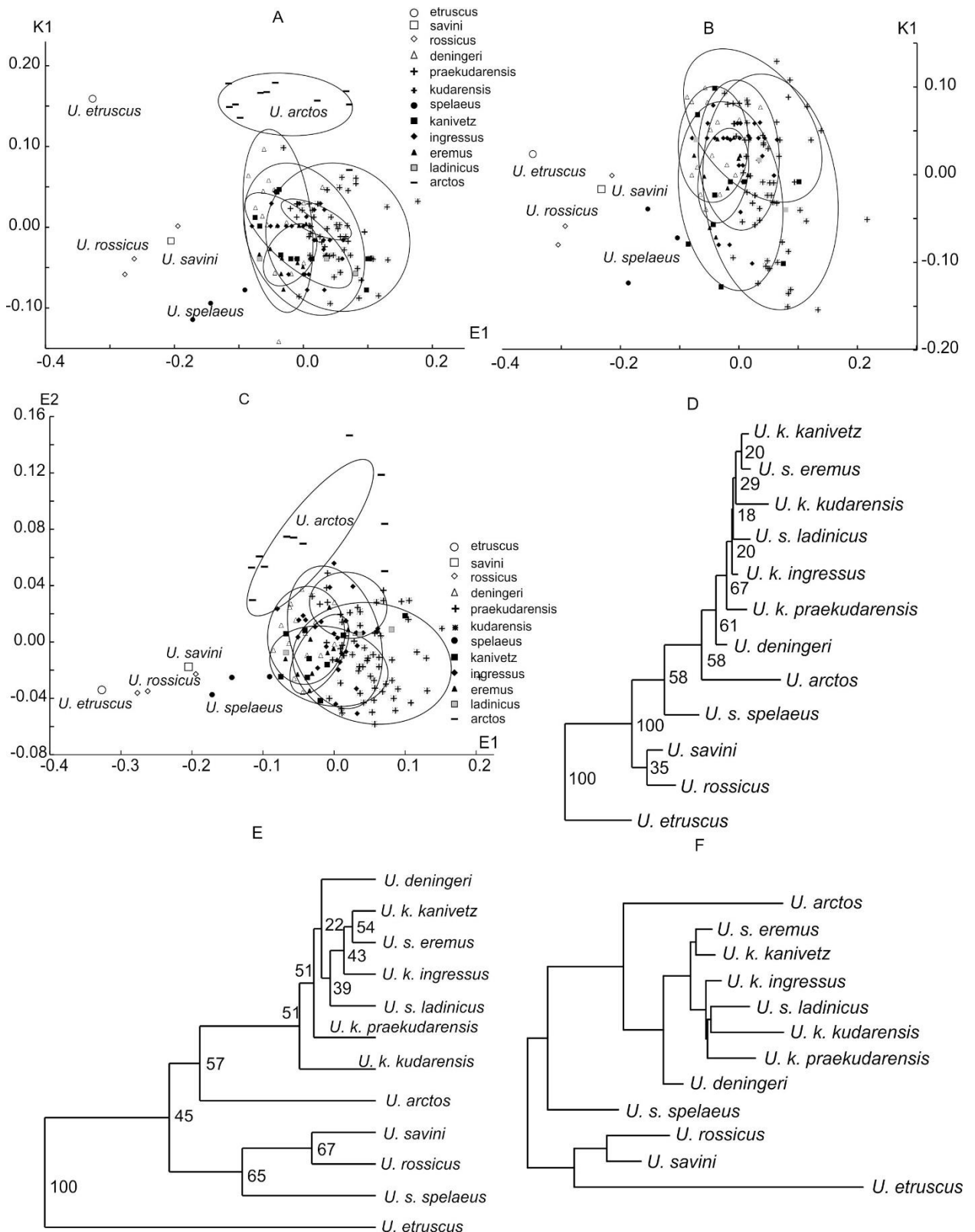

Fig. S4. Scatterplot of the first dimensions of “size” (E1) and “shape” (K1) morphospaces reproduced variation of mtc I in males: A, C – models with *U. arctos*; B – model without *U. arctos*; C – “size” morphospace; D – NJ tree; E – UGMA dendrogram (cophenetic correlation – 0.92); F – Sattath-Tversky (Sattath, Tversky, 1977) additive tree. All classifications based on the coordinates of samples’ centroids in the “size” (E1, E2) and “shape” (K1, K2) morphospaces (numbers near the nodes - bootstrap (1000 repeats) supports in %). Ellipses’ horizontal and vertical projection onto the E1 (E2) and K1 axes are equal to the “sample mean” (centroid) ± “sample range” x 0.95.

## Females

Table S7. Description of the modeled morphological spaces of mtc I for females of cave bears and brown bear. Correlation coefficients among the measures and dimensions of two morphospace models (MDS axes: E1–E2, K1–K2);  $r^2$  – coefficients of determination in the linear multiple regression models.

Measures	Morphospaces with <i>U. arctos</i>					Morphospaces without <i>U. arctos</i>				
	“Size”		“Shape”		$r^2$	“Size”		“Shape”		$r^2$
	morphospace		morphospace			morphospace		morphospace		
	E1	E2	K1	K2	E	K1	K2			
GL	0.57	0.56	0.33	-0.29	0.84	0.85	-0.13	-0.25	0.76	
Bp	0.95	-0.01	-0.47	0.03	0.90	0.93	-0.28	-0.13	0.85	
Dp	0.84	0.46	-0.41	-0.43	0.95	0.84	-0.55	-0.17	0.85	
SD	0.90	-0.27	-0.53	0.18	0.91	0.89	-0.19	0.27	0.91	
Bd	0.93	-0.10	-0.35	0.20	0.89	0.92	-0.06	0.00	0.84	
Dd	0.89	-0.21	-0.22	0.31	0.90	0.86	0.17	-0.19	0.88	
ip	0.23	-0.15	-0.66	0.32	0.79	0.17	0.12	0.32	0.43	
Relative variance (%) of dimensions associated with taxonomical composition										
	68.8	59.9	39.5	31.6		73.6	32.4	6.7		

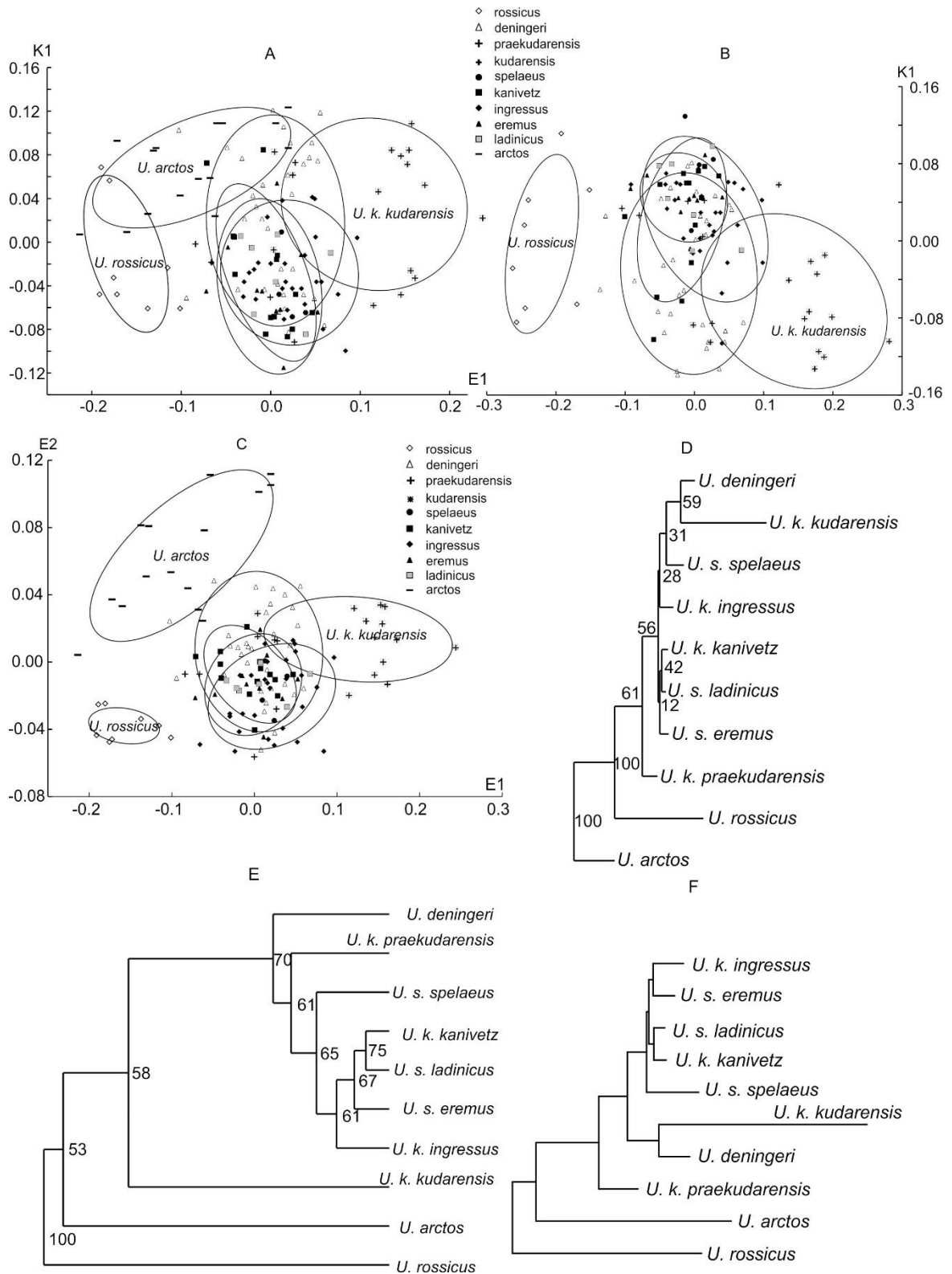

Fig. S5. Scatterplot of the first dimensions of “size” (E1) and “shape” (K1) morphospaces reproduced variation of mtc I in females: A, C – models with *U. arctos*; B – model without *U. arctos*; C – “size” morphospace; D – NJ tree; E – UGMA dendrogram (cophenetic correlation – 0.95); F – Sattath-Tversky (Sattath, Tversky, 1977) additive tree. All classifications based on the coordinates of samples’ centroids in the “size” (E1, E2) and “shape” (K1, K2) morphospaces (numbers near the nodes - bootstrap (1000 repeats) supports in %). Ellipses’ horizontal and vertical projection onto the E1 (E2) and K1 axes are equal to the “sample mean” (centroid) ± “sample range” x 0.95.

**METACARPAL BONE II (MTC II)****Males and females**

Table S8. Sample numbers (N), means (M), and standard errors (m) of the variables of mtc II among different forms of bears

Form	GL		Bp		Dp		SD	
	N	M±m	N	M±m	N	M±m	N	M±m
<i>U. deningeri</i>	41	72.8±0.80	42	18.9±0.29	40	26.9±0.40	42	15.4±0.24
<i>U. k. praekudarensis</i>	10	83.4±1.85	14	22.2±0.66	12	32.7±1.06	14	17.5±0.57
<i>U. k. kudarensis</i>	72	83.7±0.51	74	22.2±0.20	74	31.7±0.28	75	17.3±0.18
<i>U. savini</i> *	1	56.8	no data		no data		1	9.9
<i>U. rossicus</i>	21	58.6±0.65	16	14.0±0.21	15	22.2±0.28	17	12.5±0.16
<i>U. s. spelaeus</i>	16	78.5±1.71	16	20.4±0.60	12	28.4±0.89	16	17.6±0.37
<i>U. k. kanivetz</i>	21	73.5±0.92	22	18.9±0.37	19	26.8±0.47	22	17.0±0.27
<i>U. s. eremus</i>	20	74.7±0.78	20	19.1±0.48	20	26.3±0.38	20	16.1±0.34
<i>U. s. ladinicus</i>	14	71.3±0.63	10	18.0±0.30	14	25.2±0.38	13	15.4±0.24
<i>U. k. ingressus</i>	53	78.4±0.78	20	21.6±0.44	19	28.9±0.56	52	17.8±0.27
<i>U. arctos</i>	26	80.8±2.29	25	16.0±0.59	22	24.9±1.08	26	12.3±0.49
	Bd		Dd					
	N	M±m	N	M±m				
<i>U. deningeri</i>	41	23.0±0.33	40	19.2±0.22				
<i>U. k. praekudarensis</i>	13	26.2±0.75	9	22.7±0.78				
<i>U. k. kudarensis</i>	68	26.9±0.23	65	22.0±0.13				
<i>U. savini</i> *	1	16.9	1	14.3				
<i>U. rossicus</i>	19	18.5±0.25	15	14.8±0.19				
<i>U. s. spelaeus</i>	16	25.0±0.51	10	19.5±0.36				
<i>U. k. kanivetz</i>	21	24.4±0.41	17	19.1±0.41				
<i>U. s. eremus</i>	20	24.0±0.39	20	19.6±0.27				
<i>U. s. ladinicus</i>	14	22.4±0.26	14	18.2±0.14				
<i>U. k. ingressus</i>	50	24.8±0.21	36	20.2±0.25				
<i>U. arctos</i>	26	20.2±0.66	23	17.7±0.56				

\* - female proposed

**Sexual dimorphism**Table S9. Sexual size dimorphism (SSD and ASSD) of mtc II in the different forms of cave bears and brown bear ;  $p$  based on Mann-Whitney U Test;  $v$ , % - relative variance associated with SSD.

	SSD						ASSD
	GL	Bp	Dp	SD	Bd	Dd	
<i>U. deningeri</i>							
Males	77.6±0.87	20.5±0.33	29.0±0.58	16.5±0.34	24.7±0.51	20.32±0.23	
Females	69.4±0.56	17.6±0.24	25.40±0.26	14.5±0.18	21.8±0.18	18.3±0.22	
SSD	5.6±0.70 (<0.001)	7.6±1.07 (<0.001)	6.6±1.17 (<0.001)	6.5±1.24 (<0.001)	6.2±1.17 (<0.001)	5.2±0.83 (<0.001)	6.28
$v$ , %	76.6	69.9	64.5	56.8	63.7	65.3	
<i>U. rossicus</i>							
Males	61.1±1.14	14.9±0.33	22.9±0.34	13.0±0.15	19.5±0.23	15.3±0.30	
Females	57.2±0.43	13.6±0.17	22.0±0.34	12.3±0.18	17.8±0.18	14.6±0.23	

	SSD						ASSD
	GL	Bp	Dp	SD	Bd	Dd	
SSD	3.3±1.03 (0.002)	4.6±1.3 (0.01)	2.0±1.07 n.s.	2.8±1.93 (0.04)	4.6±0.78 ( $<0.001$ )	2.3±1.26 n.s.	3.25
v, %	64.7	61.2	-	17.9	79.9	-	
<i>U. k. praekudarensis</i>							
Males	86.6±1.13	23.8±0.56	34.5±0.81	18.7±0.47	28.0±0.49	23.8±0.43	
Females	76.0±1.78	20.1±0.72	29.3±1.78	15.8±0.76	24.0±0.89	20.4±1.63	
SSD	6.5±1.3 (0.02)	8.4±2.09 (0.01)	8.2±3.08 (0.03)	8.4±2.60 (0.02)	7.7±1.96 (0.004)	7.7±3.83 n.s.	7.81
v, %	83.7	59.7	65.0	18.9	58.5	-	
<i>U. k. kudarensis</i>							
Males	86.5±0.43	23.1±0.23	32.5±0.34	18.2±0.17	27.8±0.27	22.4±0.15	
Females	79.9±0.53	21.0±0.24	30.6±0.39	16.2±0.25	25.5±0.24	21.4±0.14	
SSD	4.0±0.41 ( $<0.001$ )	4.8±0.72 ( $<0.001$ )	3.0±0.82 (0.002)	5.8±0.88 ( $<0.001$ )	4.3±0.68 ( $<0.001$ )	2.3±0.47 ( $<0.001$ )	4.03
v, %	70.6	55.3	18.4	47.8	51.4	36.8	
<i>U. s. spelaeus</i>							
Males	86.2±0.90	22.8±0.81	31.2±1.19	19.2±0.32	27.0±0.69	20.4±1.07	
Females	73.9±1.11	19.0±0.35	26.4±0.46	16.7±0.23	23.8±0.30	19.1±0.16	
SSD	7.7±0.9 (0.001)	9.1±2.12 (0.001)	8.3±2.22 (0.02)	7.0±1.1 (0.001)	6.3±1.48 (0.003)	3.3±2.74 n.s.	6.94
v, %	84.1	75.5	64.0	72.7	51.9	-	
<i>U. s. ladinicus</i>							
Males	73.4±0.87	19.0±0.41	26.1±0.43	16.2±0.39	23.1±0.24	18.3±0.35	
Females	70.2±0.58	17.4±0.23	24.7±0.48	15.0±0.20	22.1±0.32	18.1±0.10	
SSD	2.2±1.7 (0.01)	4.5±1.29 (0.007)	2.8±1.27 n.s.	3.8±1.39 (0.03)	2.3±0.89 n.s.	0.5±1.0 n.s.	2.71
v, %	52.5	62.4	-	51.3	-	-	
<i>U. s. eremus</i>							
Males	79.9±1.29	22.6±0.76	29.1±0.58	18.6±0.74	27.1±0.44	21.4±0.43	
Females	75.5±0.57	18.3±0.30	25.6±0.24	15.5±0.18	23.3±0.20	19.1±0.20	
SSD	4.2±0.92 (0.004)	10.6±2.0 (0.003)	6.3±1.16 (0.003)	8.9±2.25 (0.003)	7.6±0.97 (0.003)	5.7±1.16 (0.004)	7.22
v, %	78.5	85.6	85.5	84.6	91.4	80.1	
<i>U. k. ingressus</i>							
Males	83.6±0.81	23.0±0.38	30.6±0.45	19.7±0.22	27.1±0.27	21.4±0.25	
Females	74.5±0.59	19.9±0.40	26.6±0.40	16.4±0.20	23.2±0.17	18.9±0.14	
SSD	5.7±0.59 ( $<0.001$ )	7.2±1.29 ( $<0.001$ )	7.0±1.06 (0.005)	9.1±0.83 ( $<0.001$ )	7.8±0.64 ( $<0.001$ )	6.2±0.71 ( $<0.001$ )	7.17
v, %	80.5	80.3	81.7	87.5	90.8	73.1	
<i>U. kanivetz</i>							
Males	79.4±1.20	21.1±0.51	29.6±1.07	18.4±0.31	27.0±0.69	21.8±0.32	
Females	71.6±0.61	18.1±0.27	26.0±0.30	16.4±0.23	23.6±0.29	18.5±0.30	
SSD	5.2±0.89 (0.001)	7.7±1.8 (0.001)	6.5±2.0 (0.003)	5.7±1.1 ( $<0.001$ )	6.7±1.48 (0.002)	8.2±1.1 (0.009)	6.66
v, %	87.6	85.4	87.0	75.6	79.7	80.0	
<i>U. arctos</i>							
Males	92.6±2.40	19.1±0.36	29.5±0.88	15.0±0.52	23.7±0.64	20.2±0.48	
Females	75.5±1.62	13.9±0.40	21.1±0.78	10.7±0.28	18.0±0.42	15.8±0.45	
SSD	11.5±1.8 ( $<0.001$ )	15.8±1.7 ( $<0.001$ )	16.6±2.4 (0.004)	16.8±2.4 ( $<0.001$ )	13.8±1.9 ( $<0.001$ )	12.2±1.8 ( $<0.001$ )	14.46

v, %	SSD						ASSD
	GL	Bp	Dp	SD	Bd	Dd	
	75.6	88.1	82.3	84.8	85.6	80.4	

### Univariate statistic

Table S10. Kruskal-Wallis test z' values (males - above diagonal and females – under diagonal) for measures of mtc II. The statistical significance values, according to 2-tailed *p* values, have been underlined.

Taxa	1	2	3	4	5	6	7	8	9	10
	GL									
<i>U. deningeri</i>	1	1.50	<u>3.54</u>	<u>5.46</u>	3.25	0.38	0.46	0.81	3.07	<u>5.02</u>
<i>U. rossicus</i>	2	2.31	<u>4.31</u>	<u>5.74</u>	<u>4.05</u>	1.47	1.46	0.40	<u>3.95</u>	<u>5.57</u>
<i>U. k. praekudarensis</i>	3	2.31	<u>3.45</u>	0.03	0.08	2.38	2.13	<u>3.42</u>	1.38	0.84
<i>U. k. kudarensis</i>	4	<u>7.41</u>	<u>8.51</u>	0.99	0.07	2.92	2.52	<u>4.20</u>	2.22	1.21
<i>U. s. spelaeus</i>	5	2.44	<u>4.08</u>	0.75	3.01	2.23	2.00	3.23	1.20	0.89
<i>U. k. kanivetz</i>	6	1.42	<u>3.36</u>	1.52	<u>5.05</u>	1.14	0.09	0.96	1.61	<u>3.30</u>
<i>U. s. eremus</i>	7	2.78	<u>4.54</u>	0.82	<u>3.63</u>	0.05	1.24	1.00	1.35	2.95
<i>U. s. ladinicus</i>	8	0.15	1.97	2.03	<u>5.16</u>	1.87	0.96	2.01	2.83	<u>4.41</u>
<i>U. k. ingressus</i>	9	<u>4.04</u>	<u>5.74</u>	0.52	<u>3.60</u>	0.50	2.08	0.65	2.74	2.65
<i>U. arctos</i>	10	2.51	<u>4.31</u>	0.96	<u>3.91</u>	0.27	1.00	0.25	1.80	0.94
	Bp									
<i>U. deningeri</i>	1	1.87	<u>3.75</u>	<u>4.66</u>	2.09	0.45	1.94	1.05	<u>3.27</u>	1.27
<i>U. rossicus</i>	2	3.10	<u>4.45</u>	<u>4.77</u>	3.18	1.91	3.00	0.66	<u>4.07</u>	0.81
<i>U. k. praekudarensis</i>	3	2.46	<u>4.44</u>	0.74	1.13	2.56	0.86	<u>3.72</u>	0.74	<u>4.42</u>
<i>U. k. kudarensis</i>	4	<u>5.50</u>	<u>7.47</u>	0.83	0.75	2.52	0.46	<u>3.89</u>	0.17	<u>5.16</u>
<i>U. s. spelaeus</i>	5	1.82	<u>4.15</u>	0.85	2.23	1.34	0.13	2.50	0.53	2.88
<i>U. k. kanivetz</i>	6	0.71	<u>3.46</u>	1.87	4.12	1.13	1.33	1.22	2.05	1.38
<i>U. s. eremus</i>	7	1.01	<u>3.71</u>	1.67	3.79	0.89	0.28	2.38	0.31	2.66
<i>U. s. ladinicus</i>	8	0.43	2.13	2.46	4.40	1.86	0.95	1.19	<u>3.30</u>	0.05
<i>U. k. ingressus</i>	9	2.83	<u>4.97</u>	0.03	1.02	0.92	2.11	1.87	2.71	<u>4.01</u>
<i>U. arctos</i>	10	3.19	0.19	<u>4.50</u>	<u>8.09</u>	<u>4.25</u>	<u>3.56</u>	<u>3.83</u>	2.09	<u>5.12</u>
	Dp									
<i>U. deningeri</i>	1	1.88	<u>4.11</u>	<u>4.10</u>	1.68	0.33	0.19	1.56	1.22	0.53
<i>U. rossicus</i>	2	2.91	<u>4.59</u>	<u>4.25</u>	2.83	1.74	1.33	0.38	2.60	2.12
<i>U. k. praekudarensis</i>	3	1.89	<u>3.58</u>	1.52	1.59	2.58	3.05	<u>4.48</u>	2.77	<u>3.27</u>
<i>U. k. kudarensis</i>	4	<u>5.33</u>	<u>7.22</u>	0.83	0.68	1.90	2.45	<u>4.16</u>	2.08	2.75
<i>U. s. spelaeus</i>	5	1.09	3.17	0.89	2.39	1.01	1.43	2.60	0.71	1.18
<i>U. k. kanivetz</i>	6	0.97	<u>3.50</u>	1.25	<u>3.64</u>	0.32	0.41	1.45	0.50	0.05
<i>U. s. eremus</i>	7	0.31	2.98	1.66	<u>4.44</u>	0.81	0.62	1.02	0.99	0.54
<i>U. s. ladinicus</i>	8	0.80	1.59	2.21	<u>4.53</u>	1.54	1.49	0.99	2.34	1.83
<i>U. k. ingressus</i>	9	1.39	<u>3.53</u>	0.74	2.26	0.20	0.57	1.09	1.80	0.60
<i>U. arctos</i>	10	2.90	0.08	<u>3.57</u>	<u>7.35</u>	3.16	<u>3.50</u>	2.97	1.54	<u>3.52</u>
	SD									
<i>U. deningeri</i>	1	1.74	2.95	2.98	<u>3.36</u>	2.12	1.92	0.47	<u>5.73</u>	1.26
<i>U. rossicus</i>	2	2.02	<u>3.74</u>	<u>3.63</u>	<u>4.07</u>	3.10	2.89	1.01	<u>5.45</u>	0.69
<i>U. k. praekudarensis</i>	3	1.70	2.98	1.09	0.62	0.47	0.31	2.62	1.38	<u>3.69</u>
<i>U. k. kudarensis</i>	4	<u>3.97</u>	<u>5.27</u>	0.68	1.73	0.38	0.43	2.27	<u>3.79</u>	<u>3.80</u>
<i>U. s. spelaeus</i>	5	<u>3.90</u>	<u>5.09</u>	1.34	1.07	1.02	0.81	3.01	0.51	<u>4.04</u>
<i>U. k. kanivetz</i>	6	<u>4.00</u>	<u>5.26</u>	1.08	0.70	0.43	0.09	2.05	1.79	2.90
<i>U. s. eremus</i>	7	1.94	<u>3.51</u>	0.31	1.47	2.09	1.89	1.94	1.40	2.63
<i>U. s. ladinicus</i>	8	0.64	2.18	1.00	2.19	2.65	2.51	0.90	<u>4.16</u>	0.47

Taxa		1	2	3	4	5	6	7	8	9	10
<i>U. k. ingressus</i>	9	<u>4.59</u>	<u>5.77</u>	1.08	0.70	0.57	0.11	2.04	2.65		<u>6.09</u>
<i>U. arctos</i>	10	2.95	0.62	<u>3.61</u>	<u>6.59</u>	<u>6.00</u>	<u>6.35</u>	<u>4.46</u>	2.88	<u>7.13</u>	
Bd											
<i>U. deningeri</i>	1		2.21	3.26	<u>4.35</u>	2.12	1.79	1.72	1.08	2.92	0.69
<i>U. rossicus</i>	2	2.09		<u>4.66</u>	<u>5.70</u>	<u>3.61</u>	3.26	3.10	0.69	<u>4.57</u>	1.42
<i>U. k. praekudarensis</i>	3	2.93	<u>4.13</u>		0.50	0.82	0.95	0.81	<u>3.44</u>	1.17	<u>3.52</u>
<i>U. k. kudarensis</i>	4	<u>6.95</u>	<u>7.57</u>	1.33		0.58	0.74	0.58	<u>3.82</u>	1.14	<u>4.34</u>
<i>U. s. spelaeus</i>	5	3.08	<u>4.40</u>	0.34	2.10		0.16	0.08	2.57	0.12	2.48
<i>U. k. kanivetz</i>	6	<u>3.41</u>	<u>4.76</u>	0.49	2.65	0.15		0.06	2.31	0.08	2.16
<i>U. s. eremus</i>	7	2.73	<u>4.19</u>	0.95	<u>3.36</u>	0.69	0.62		2.24	0.00	2.07
<i>U. s. ladinicus</i>	8	0.44	2.08	2.21	<u>4.60</u>	2.15	2.23	1.70		3.02	0.51
<i>U. k. ingressus</i>	9	3.12	<u>4.58</u>	1.06	<u>4.04</u>	0.81	0.77	0.06	1.81		3.19
<i>U. arctos</i>	10	2.36	0.00	<u>4.38</u>	<u>8.60</u>	<u>4.77</u>	<u>5.27</u>	<u>4.65</u>	2.24	<u>5.21</u>	
DD											
<i>U. deningeri</i>	1		1.81	<u>4.48</u>	<u>4.86</u>	0.40	1.55	1.22	1.35	2.11	0.16
<i>U. rossicus</i>	2	3.08		<u>5.03</u>	<u>4.91</u>	1.60	2.59	2.38	0.37	3.23	1.80
<i>U. k. praekudarensis</i>	3	1.65	<u>3.31</u>		1.64	2.66	1.63	2.25	<u>4.65</u>	3.04	<u>4.00</u>
<i>U. k. kudarensis</i>	4	<u>5.86</u>	<u>7.65</u>	1.11		1.93	0.73	1.39	<u>4.42</u>	2.53	<u>3.80</u>
<i>U. s. spelaeus</i>	5	1.53	<u>3.71</u>	0.51	2.42		0.89	0.56	1.28	0.73	0.28
<i>U. k. kanivetz</i>	6	0.46	3.20	1.35	<u>4.61</u>	1.09		0.39	2.27	0.44	1.38
<i>U. s. eremus</i>	7	1.99	<u>4.50</u>	0.58	<u>3.27</u>	0.03	1.34		2.03	0.05	1.03
<i>U. s. ladinicus</i>	8	0.55	1.99	1.83	<u>4.72</u>	1.71	0.86	2.01		2.76	1.37
<i>U. k. ingressus</i>	9	1.53	<u>4.16</u>	0.84	<u>3.84</u>	0.38	0.92	0.46	1.66		1.63
<i>U. arctos</i>	10	2.69	0.56	3.04	<u>7.68</u>	3.40	2.83	4.23	1.58	<u>3.86</u>	



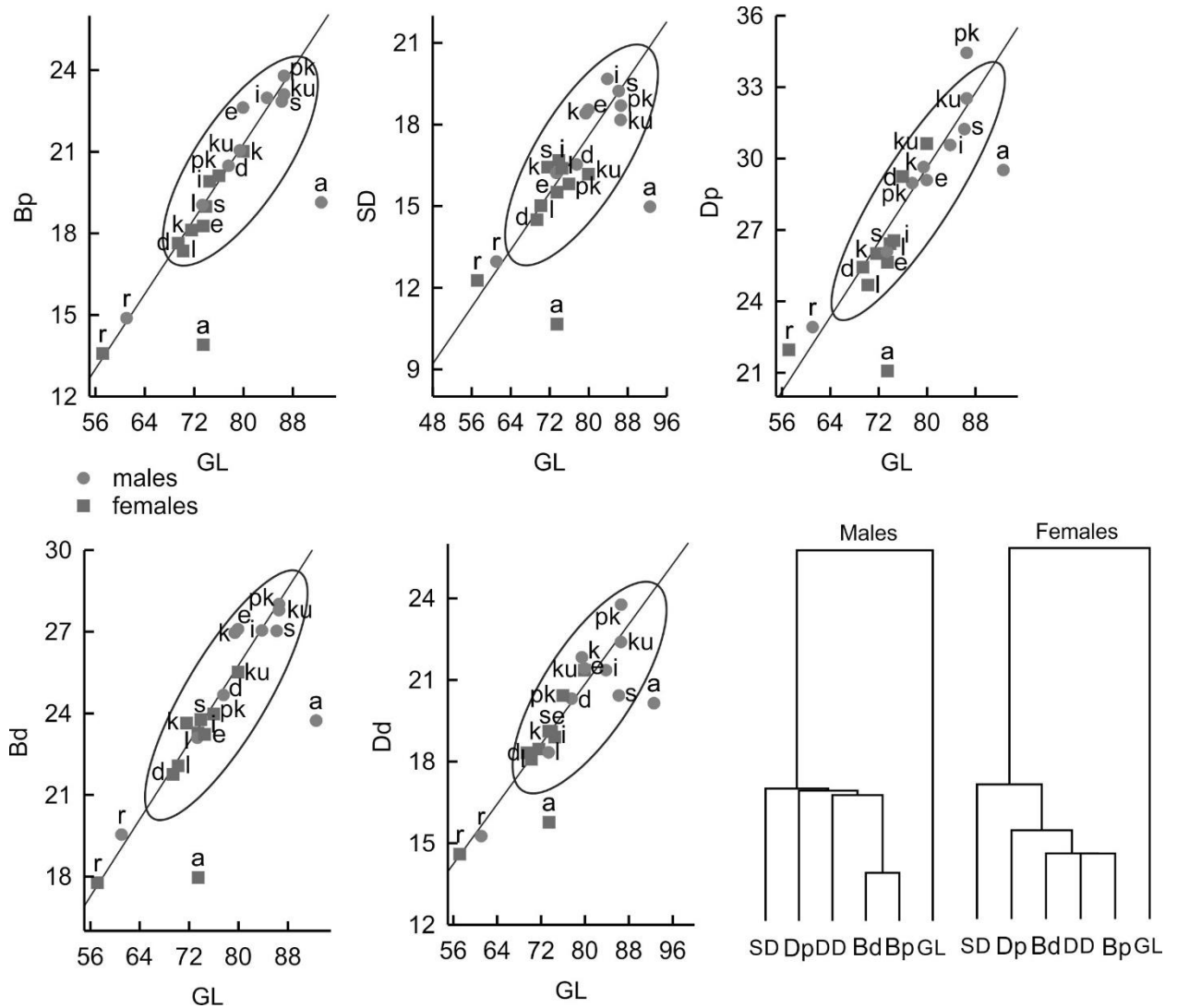

Fig. S6. The scatterplots of length of mtc II and the other measures (BP – DD) and relationships between measures of mtc II (single linkage, correlation distances used): et – *U. etruscus*, a – *U. arctos*, r – *U. rossicus*, d – *U. deningeri*, pk – *U. k. praekudarensis*, ku – *U. k. kudarensis*, s – *U. s. spelaeus*, k – *U. k. kanivetz*, i – *U. k. ingressus*, e – *U. s. eremus*, l – *U. s. ladinicus*. The dashed lines are lines of regressions and ellipses' horizontal and vertical projections onto the axes are equal to the “sample mean ± “sample range” x 0.95.

Table S11. Statistical parameters of measures of mtc II among different bears and sexes: m – males, f – females.

Taxa	Sex	GL - N	GL	Std.Dev.	BP - N	BP	Std.Dev.	Dp- N	Dp	Std.Dev.	SD - N	SD	Std.Dev.	Bd - N	Bd	Std.Dev.	Dd- N	Dd	Std.Dev.
<i>U. rossicus</i>	m	8	61.1	3.24	5	14.9	0.73	4	22.9	0.68	5	13.0	0.33	8	19.5	0.65	5	15.3	0.67
	f	13	57.2	1.56	11	13.6	0.56	11	22.0	1.13	12	12.3	0.64	11	17.8	0.61	10	14.6	0.72
<i>U. deningeri</i>	m	17	77.6	3.60	18	20.5	1.41	17	29.0	2.39	18	16.5	1.45	17	24.7	2.09	17	20.3	0.97
	f	24	69.4	2.76	24	17.6	1.16	23	25.4	1.26	24	14.5	0.89	24	21.8	0.89	23	18.3	1.05
<i>U. k. praekudar.</i>	m	7	86.6	3.00	8	23.8	1.57	8	34.5	2.30	8	18.7	1.34	7	28.0	1.30	6	23.8	1.05
	f	3	76.0	3.09	6	20.1	1.76	4	29.3	3.56	6	15.8	1.87	6	24.0	2.19	3	20.4	2.82
<i>U. k. kudarensis</i>	m	41	86.6	2.73	43	23.1	1.36	43	32.5	2.25	44	18.2	1.15	40	27.8	1.69	40	22.4	0.98
	f	31	79.9	2.96	31	21.0	1.31	31	30.6	2.19	31	16.2	1.39	28	25.5	1.26	25	21.4	0.70
<i>U. s. spelaeus</i>	m	6	86.2	2.21	6	22.9	1.98	5	31.2	2.65	6	19.2	0.78	6	27.0	1.69	3	20.4	1.85
	f	10	73.9	3.52	10	19.0	1.11	7	26.4	1.21	10	16.7	0.74	10	23.8	0.95	7	19.1	0.44
<i>U. k. kanivetz</i>	m	5	79.4	2.68	6	21.1	1.24	4	29.7	2.14	6	18.4	0.75	5	27.0	1.54	3	21.8	0.55
	f	16	71.6	2.45	16	18.1	1.07	15	26.0	1.14	16	16.4	0.94	16	23.6	1.16	14	18.5	1.12
<i>U. s. eremus</i>	m	4	79.9	2.59	4	22.6	1.52	4	29.1	1.17	4	18.6	1.48	4	27.1	0.89	4	21.4	0.86
	f	16	73.5	2.29	16	18.3	1.19	16	25.6	0.95	16	15.5	0.73	16	23.3	0.81	16	19.1	0.78
<i>U. s. ladinicus</i>	m	5	73.4	1.94	5	19.0	0.91	5	26.1	0.97	5	16.2	0.87	5	23.1	0.54	5	18.3	0.78
	f	9	70.2	1.73	9	17.4	0.69	8	24.7	1.36	9	15.0	0.59	9	22.1	0.96	8	18.1	0.27
<i>U. k. ingressus</i>	m	22	83.8	3.26	11	23.0	1.26	11	30.6	1.51	22	19.7	1.03	21	27.1	1.22	19	21.4	1.09
	f	31	74.5	3.29	9	19.9	1.21	8	26.6	1.14	30	16.4	1.12	29	23.2	0.94	17	18.9	0.60
<i>U. arctos</i>	m	10	92.6	7.60	10	19.1	1.12	10	29.5	2.79	10	15.0	1.66	10	23.7	2.03	10	20.2	1.51
	f	16	73.5	6.48	15	13.9	1.53	12	21.1	2.70	16	10.7	1.12	16	18.0	1.66	13	15.8	1.62

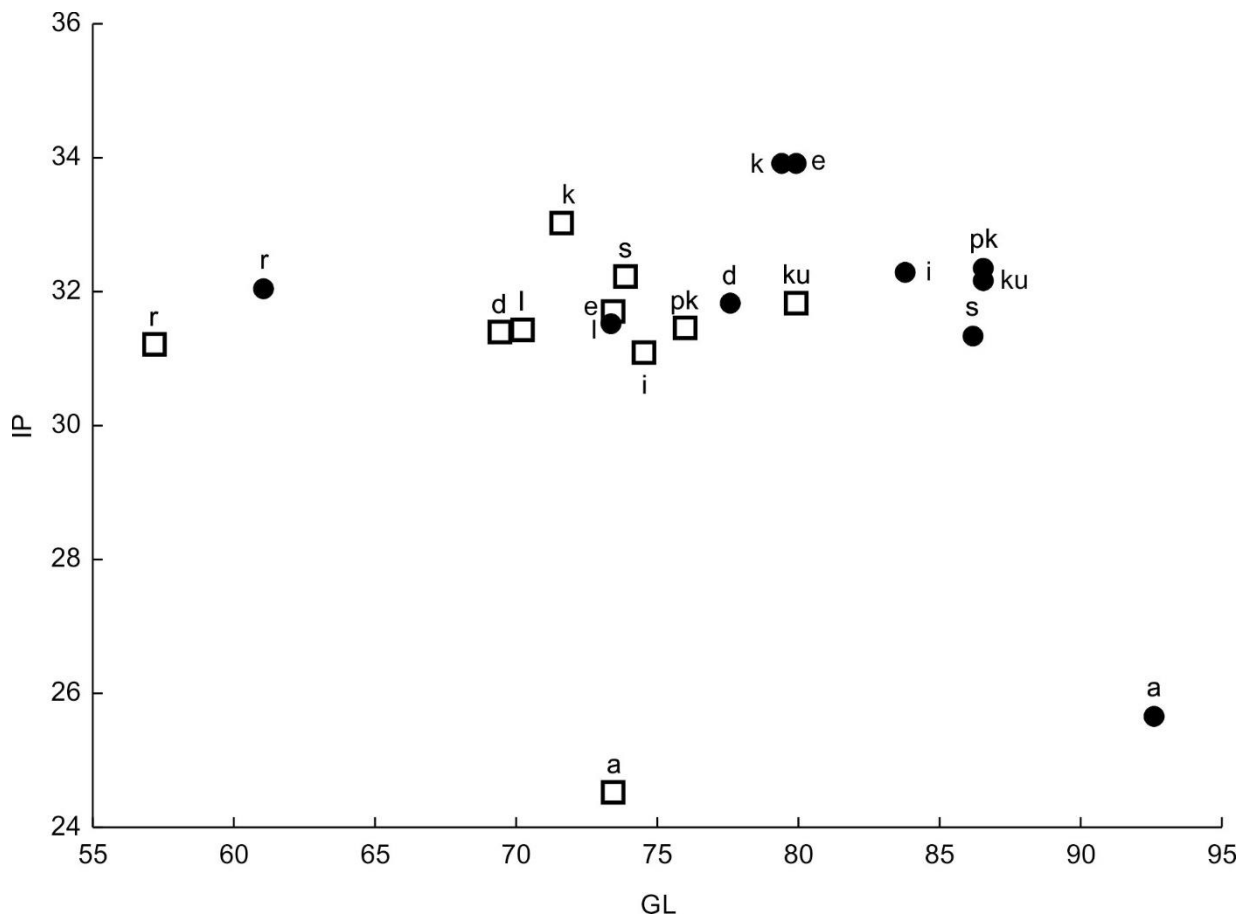

Fig. S7. The scatterplot of Index plumpness (ip) and GL of mtc II: a – *U. arctos*, r – *U. rossicus*, d – *U. deningeri*, pk – *U. k. praekudarensis*, ku – *U. k. kudarensis*, s – *U. s. spelaeus*, k – *U. k. kanivetz*, i – *U. k. kanivetz*, e – *U. s. eremus*, l – *U. s. ladinicus*. Point – males, square – females.

**Multivariate analysis**

Table S12. Description of the modeled morphological spaces for cave bears and brown bear mtc II. Correlation coefficients among the measures and dimensions of two morphospace models (MDS axes: E1–E2, K1–K2);  $r^2$  – coefficients of determination in the linear multiple regression models.

Measures	Morphospaces with <i>U. arctos</i>				Morphospaces without <i>U. arctos</i>				
	“Size”		“Shape”	$r^2$	“Size”		“Shape”		$r^2$
	morphospace		morphospace		morphospace		morphospace		
	E1	E2	K1		E1	E2	K1	K2	
GL	0.83	0.49	-0.41	0.89	0.96	0.09	-0.51	0.17	0.93
Bp	0.96	-0.07	-0.04	0.93	0.95	-0.10	-0.32	0.41	0.97
Dp	0.95	0.18	-0.24	0.96	0.94	0.22	-0.52	0.23	0.94
SD	0.90	-0.33	0.26	0.96	0.88	-0.42	-0.01	0.13	0.97
Bd	0.97	-0.08	-0.01	0.95	0.97	-0.08	-0.33	0.11	0.95
Dd	0.96	0.13	-0.22	0.93	0.95	0.15	-0.53	0.10	0.94
ip	0.31	-0.33	0.20	0.65	0.28	-0.34	0.27	-0.09	0.28
Relative variance (%) of dimensions associated with taxonomical composition									
	62.9	70.5	64.8		67.8	44.3	57.5	14.1	

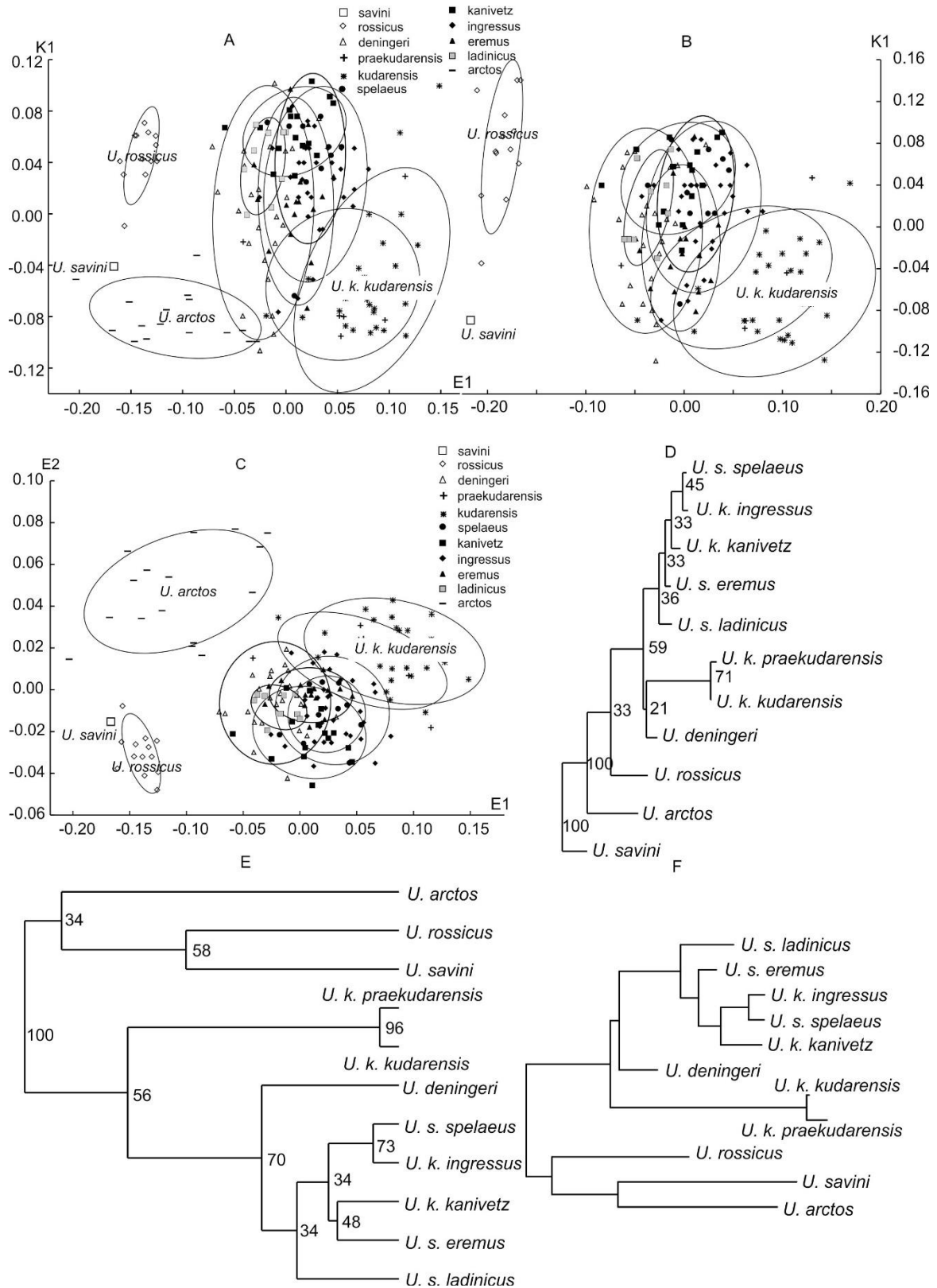

Fig. S8. Scatterplot of the first dimensions of "size" (E1) and "shape" (K1) morphospaces reproduced variation of mtc II in males and females: A, C – models with *U. arctos*; B – model without *U. arctos*; C – "size" morphospace; D – NJ tree; E – UGMA dendrogram (cophenetic correlation – 0.89); F – Sattath-Tversky (Sattath, Tversky, 1977) additive tree. All classifications based on the coordinates of samples' centroids in the "size" (E1, E2) and "shape" (K1, K2) morphospaces (numbers near the nodes - bootstrap (1000 repeats) supports in %). Ellipses' horizontal and vertical projection onto the E1 (E2) and K1 axes are equal to the "sample mean" (centroid)  $\pm$  "sample range"  $\times$  0.95.

**Males**

Table S13. Description of the modeled morphological spaces for males of cave bears and brown bear mtc II. Correlation coefficients among the measures and dimensions of two morphospace models (MDS axes: E1–E2, K1–K2);  $r^2$  – coefficients of determination in the linear multiple regression models.

Measures	Morphospaces with <i>U. arctos</i>				Morphospaces without <i>U. arctos</i>				
	“Size”		“Shape”	$r^2$	“Size”		“Shape”		$r^2$
	morphospace		morphospace		morphospace		morphospace		
E1	E2	K1	E1	E2	K1	K2			
GL	0.72	0.56	-0.30	0.78	0.93	-0.14	0.18	-0.00	0.89
Bp	0.92	-0.14	0.16	0.88	0.93	0.04	0.00	0.10	0.89
Dp	0.91	0.30	-0.25	0.90	0.91	-0.36	0.39	-0.06	0.91
SD	0.85	-0.37	0.38	0.93	0.86	0.39	-0.28	0.05	0.95
Bd	0.95	-0.06	0.06	0.93	0.95	-0.01	0.04	-0.26	0.96
Dd	0.92	0.21	-0.18	0.88	0.93	-0.29	0.29	-0.11	0.20
ip	0.27	-0.27	0.31	0.52	0.24	0.27	-0.30	-0.53	0.46
Relative variance (%) of dimensions associated with taxonomical composition									
	79.9	74.0	50.9		83.6	51.3	52.3	6.5	

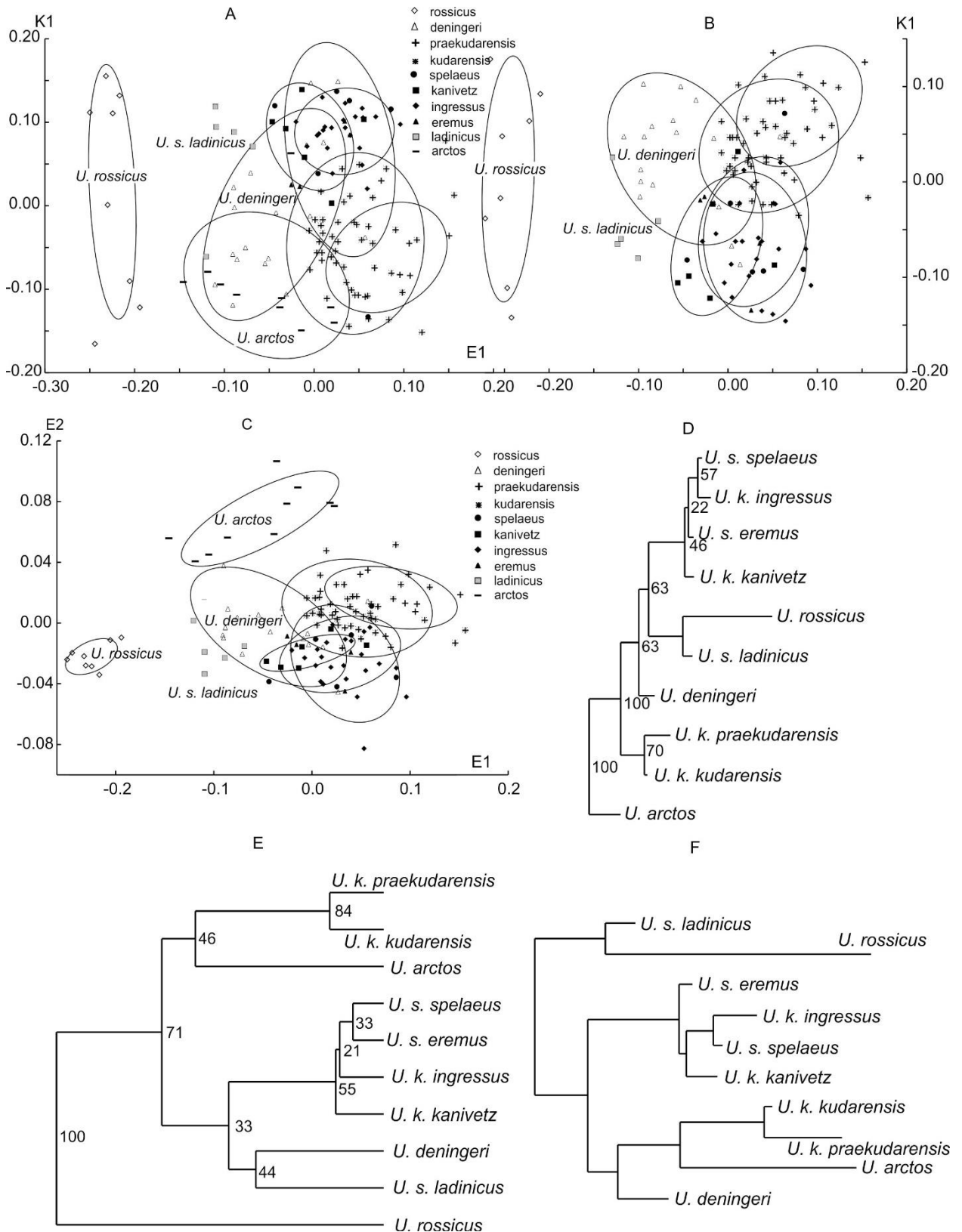

Fig. S9. Scatterplot of the first dimensions of "size" (E1) and "shape" (K1) morphospaces reproduced variation of mtc II in males: A, C – models with *U. arctos*; B – model without *U. arctos*; C – "size" morphospace; D – NJ tree; E – UGMA dendrogram (cophenetic correlation – 0.88); F – Sattath-Tversky (Sattath, Tversky, 1977) additive tree. All classifications based on the coordinates of samples' centroids in the "size" (E1, E2) and "shape" (K1, K2) morphospaces (numbers near the nodes - bootstrap (1000 repeats) supports in %). Ellipses' horizontal and vertical projection onto the E1 (E2) and K1 axes are equal to the "sample mean" (centroid) ± "sample range" x 0.95.

**Females**

Table S14. Description of the modeled morphological spaces for females of cave bears and brown bear mtc II. Correlation coefficients among the measures and dimensions of two morphospace models (MDS axes: E1–E2, K1–K2);  $r^2$  – coefficients of determination in the linear multiple regression models.

Measures	Morphospaces with <i>U. arctos</i>				$r^2$	Morphospaces without <i>U. arctos</i>			
	“Size” morphospace		“Shape” morphospace			morphospace	“Shape” morphospace		$r^2$
	E1	E2	K1	K2			E1	K1	
GL	0.76	0.61	-0.43	-0.46	0.96	0.94	-0.60	0.15	0.92
Bp	0.96	-0.07	0.00	-0.11	0.93	0.94	-0.39	0.48	0.94
Dp	0.93	0.09	-0.17	-0.06	0.91	0.92	-0.51	0.39	0.86
SD	0.88	-0.40	0.40	-0.18	0.96	0.82	-0.01	0.05	0.90
Bd	0.97	-0.13	0.11	-0.23	0.95	0.96	-0.37	0.17	0.92
Dd	0.96	0.09	-0.13	-0.17	0.92	0.94	-0.56	0.18	0.91
ip	0.22	-0.41	0.37	0.17	0.79	0.20	0.37	0.06	0.28
Relative variance (%) of dimensions associated with taxonomical composition									
	84.9	70.1	59.9	33.9		85.7	50.1	21.6	



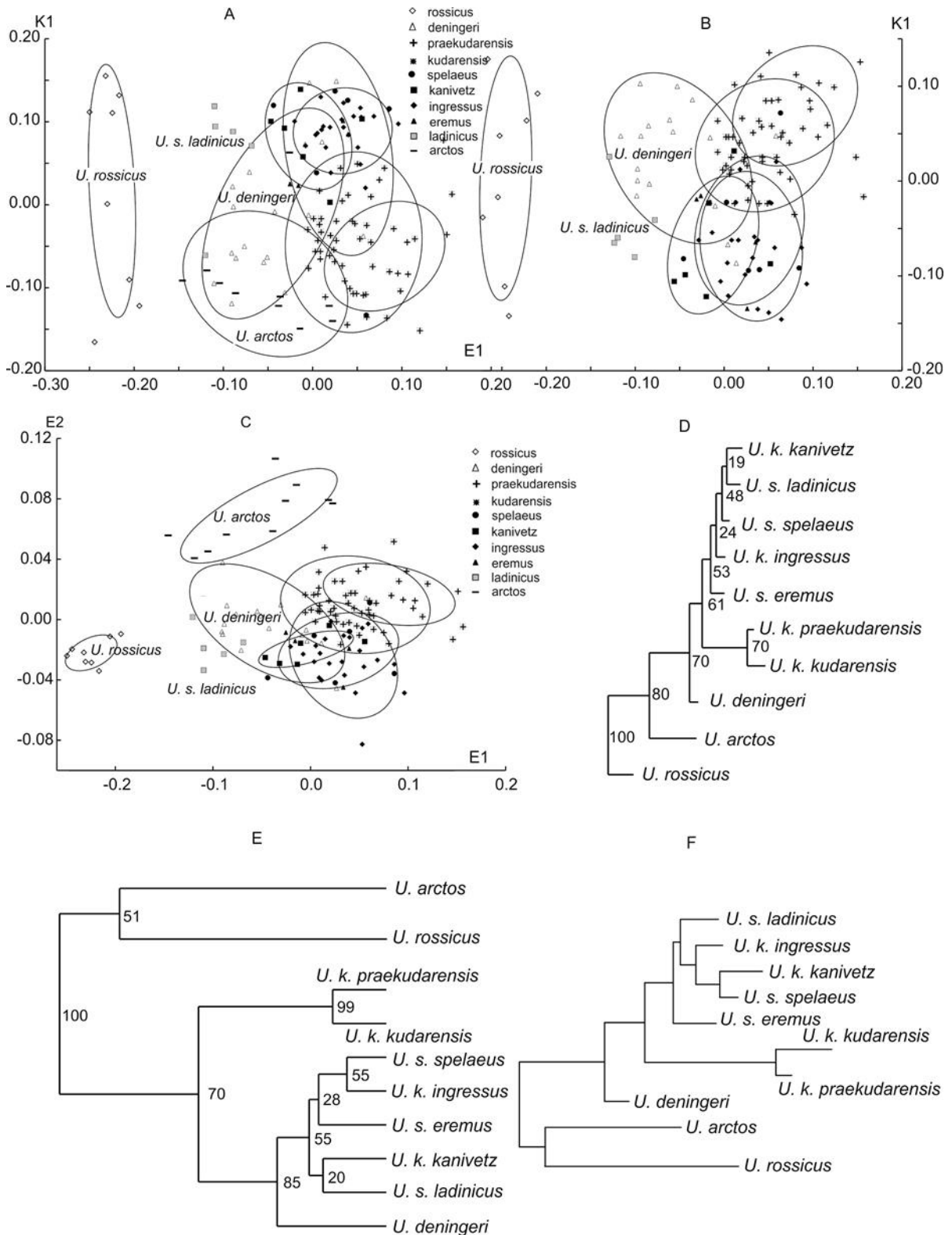

Fig. S10. Scatterplot of the first dimensions of “size” (E1) and “shape” (K1) morphospaces reproduced variation of mtc II in females A, C – models with *U. arctos*; B – model without *U. arctos*; C – “size” morphospace; D – NJ tree; E – UGMA dendrogram (cophenetic correlation – 0.92); F – Sattath-Tversky (Sattath, Tversky, 1977) additive tree. All classifications based on the coordinates of samples’ centroids in the “size” (E1, E2) and “shape” (K1, K2) morphospaces (numbers near the nodes - bootstrap (1000 repeats) supports in %). Ellipses’ horizontal and vertical projection onto the E1 (E2) and K1 axes are equal to the “sample mean”(centroid) ± “sample range” x 0.95.

**METACARPAL BONE III (MTC III)****Males and females**

Table S15. Sample numbers (N), means (M), and standard errors (m) of the variables of mtc III among different forms of bears

Form	GL		Bp		Dp		SD	
	N	M±m	N	M±m	N	M±m	N	M±m
<i>U. etruscus</i>	1	66.1		no data		no data	1	9.6
<i>U. deningeri</i>	34	76.1±0.80	34	19.1±0.30	31	27.4±0.49	36	14.7±0.20
<i>U. k. praekudarensis</i>	10	81.8±2.80	12	19.3±0.76	8	29.3±1.57	12	15.5±0.63
<i>U. k. kudarensis</i>	72	86.8±0.64	72	21.3±0.21	70	32.6±0.31	75	17.4±0.23
<i>U. rossicus</i>	19	62.3±0.87	15	16.3±0.40	15	22.1±0.35	15	13.3±0.25
<i>U. s. spelaeus</i>	14	82.3±1.68	14	20.5±0.64	7	29.7±1.16	14	16.8±0.43
<i>U. k. kanivetz</i>	17	77.4±1.15	17	19.1±0.30	17	27.4±0.53	17	15.6±0.39
<i>U. s. eremus</i>	20	81.0±1.25	20	20.7±0.46	20	30.7±0.59	20	16.5±0.39
<i>U. s. ladinicus</i>	13	75.1±1.28	13	18.3±0.44	13	28.2±0.69	13	14.4±0.27
<i>U. k. ingressus</i>	52	84.8±0.74	26	21.7±0.34	23	33.0±0.57	54	17.6±0.27
<i>U. arctos</i>	28	79.4±1.76	29	16.7±0.48	20	25.2±0.99	29	12.1±0.41
	Bd		Dd					
	N	M±m	N	M±m				
<i>U. etruscus</i>	1	15.9	1	12.9				
<i>U. deningeri</i>	34	22.6±0.31	32	19.6±0.25				
<i>U. k. praekudarensis</i>	11	24.3±0.97	10	21.3±0.79				
<i>U. k. kudarensis</i>	69	26.5±0.27	71	22.5±0.19				
<i>U. rossicus</i>	19	19.4±0.36	13	15.6±0.25				
<i>U. s. spelaeus</i>	13	24.8±0.62	6	20.7±0.46				
<i>U. k. kanivetz</i>	17	23.6±0.36	15	19.2±0.35				
<i>U. s. eremus</i>	20	25.5±0.46	20	21.1±0.35				
<i>U. s. ladinicus</i>	13	22.6±0.46	13	19.2±0.36				
<i>U. k. ingressus</i>	50	25.4±0.34	38	20.9±0.29				
<i>U. arctos</i>	28	19.1±0.52	19	17.3±0.54				

**Sexual dimorphism**

Table S16. Sexual size dimorphism (SSD and ASSD) of mtc III in the different forms of cave bears and brown bear ; p based on Mann-Whitney U Test; v, % - relative variance associated with SSD.

	SSD						ASSD
	GL	Bp	Dp	SD	Bd	Dd	
	<i>U. deningeri</i>						
Males	89.4±2.11	21.5±0.31	33.9±0.52	17.3±0.48	26.8±0.46	23.2±0.71	
Females	73.9±0.70	18.2±0.30	26.1±0.41	14.1±0.22	21.7±0.24	19.0±0.24	
SSD	4.3±0.83	6.2±1.01	6.7±1.54	5.1±1.09	6.4±0.85	4.9±1.08	5.60
	(<0.001)	(<0.001)	(<0.001)	(<0.001)	(<0.001)	(<0.001)	
v, %	69.8	52.8	61.2	50.4	75.6	54.3	
	<i>U. rossicus</i>						
Males	67.5±1.72	17.9±1.40	25.1±1.25	14.7±1.15	21.6±0.83	16.4±0.05	
Females	60.9±0.64	16.1±0.39	22.7±0.29	13.0±0.20	18.8±0.23	15.4±0.28	
SSD	5.1±1.43	5.4±4.29	4.8±2.69	5.8±4.22	6.8±2.13	3.0±0.89	5.14

	SSD						ASSD
	GL (0.01)	Bp n.s.	Dp n.s.	SD n.s.	Bd (0.005)	Dd n.s.	
v, %	41.6	-	-	-	79.6	-	
<i>U. k. praekudarensis</i>							
Males	89.4±2.11	21.5±0.31	33.9±0.52	17.3±0.48	26.8±0.46	23.2±0.71	
Females	74.2±1.36	17.2±0.77	26.2±0.75	13.8±0.54	21.4±0.96	19.3±0.63	
SSD	9.3±1.54 (0.01)	11.1±2.17 (0.004)	12.9±1.53 (0.04)	11.3±2.34 (0.008)	11.1±2.21 (0.008)	9.3±2.24 (0.02)	10.83
v, %	86.3	68.6	93.7	66.2	80.4	87.4	
<i>U. k. kudarensis</i>							
Males	89.4±0.48	22.0±0.19	35.5±0.29	18.3±0.19	27.6±0.20	23.1±0.16	
Females	80.2±0.80	19.5±0.32	30.4±0.58	15.1±0.32	24.1±0.41	21.0±0.33	
SSD	5.4±0.55 (0.009)	6.0±0.90 (0.01)	4.9±1.01 (0.02)	8.8±1.09 n.s.	7.7±0.89 (0.009)	5.9±0.82 n.s.	6.26
v, %	76.2	60.8	51.0	-	69.7	-	
<i>U. s. spelaeus</i>							
Males	90.4±1.26	23.1±1.44	33.9±1.30	18.8±0.34	27.4±0.64	-	
Females	77.6±0.60	19.5±0.37	28.1±0.49	15.9±0.29	23.7±0.47	-	
SSD	7.6±0.83 (0.005)	8.4±3.51 (0.02)	9.43±2.25 n.s.	8.4±1.30 (0.006)	7.3±1.56 (0.009)	no data	8.22
v, %	93.6	38.2	-	88.4	73.6	-	
<i>U. s. ladinicus</i>							
Males	83.7±2.30	21.2±0.10	33.3±0.90	15.8±0.40	25.7±0.85	21.7±0.75	
Females	73.6±0.82	17.7±0.30	27.3±0.34	14.2±0.24	22.0±0.29	18.7±0.21	
SSD	6.4±1.55 n.s.	8.9±0.80 n.s.	9.9±1.59 n.s.	5.4±1.56 n.s.	7.7±1.89 n.s.	7.3±1.94 n.s.	7.60
v, %	-	-	-	-	-	-	
<i>U. s. eremus</i>							
Males	85.4±1.15	22.3±0.23	33.0±0.46	17.7±0.38	27.2±0.37	22.3±0.34	
Females	76.5±0.95	19.2±0.55	28.5±0.38	15.2±0.39	23.8±0.35	19.9±0.31	
SSD	5.5±0.92 (0.004)	7.5±1.44 (0.003)	7.3±0.98 (0.003)	7.5±1.66 (0.003)	6.6±0.99 (0.003)	5.5±1.09 (0.004)	6.66
v, %	77.5	72.6	84.4	66.4	81.2	71.0	
<i>U. k. ingressus</i>							
Males	88.1±0.96	22.8±0.27	34.6±0.86	19.2±0.25	27.7±0.21	22.2±0.27	
Females	82.0±0.76	20.0±0.34	30.1±0.68	16.1±0.21	23.5±0.23	19.3±0.21	
SSD	3.6±0.72 (<0.001)	6.6±1.02 (<0.001)	7.0±1.22 (<0.001)	8.7±0.94 (<0.001)	8.2±0.61 (<0.001)	6.9±0.83 (<0.001)	6.83
v, %	76.5	75.8	75.8	80.4	93.8	81.1	
<i>U. kanivetz</i>							
Males	85.7±1.99	21.1±0.15	30.6±1.18	16.4±0.29	26.1±0.26	19.4±1.73	
Females	75.6±0.67	18.7±0.24	26.8±0.41	15.5±0.30	23.1±0.27	19.1±0.24	
SSD	6.3±1.31 (0.01)	5.9±0.71 (0.01)	6.7±2.19 (0.02)	3.0±1.32 n.s.	6.1±0.77 (0.01)	0.8±4.54 n.s.	4.80
v, %	86.6	75.7	71.3	-	81.7	-	
<i>U. arctos</i>							
Males	92.5±3.03	19.8±0.85	29.6±1.34	14.9±0.82	23.1±0.99	19.8±0.64	
Females	75.9±1.28	15.7±0.39	23.2±0.60	11.2±0.28	18.0±0.36	16.1±0.47	
SSD	9.9±1.96 (<0.001)	11.4±2.67 (<0.001)	12.2±2.81 (0.003)	14.2±3.33 (<0.001)	12.3±2.59 (<0.001)	10.2±2.2 (0.003)	11.70
v, %	74.3	59.3	67.2	68.5	75.6	70.0	

## Univariate analysis

Table S17. Kruskal-Wallis test z' values (males - above diagonal and females – under diagonal) for measures of mtc III. The statistical significance values, according to 2-tailed *p* values, have been underlined.

Taxa		1	2	3	4	5	6	7	8	9	10
		GL									
<i>U. deningeri</i>	1		2.90	<u>4.94</u>	0.69	3.26	1.26	1.78	0.50	<u>3.63</u>	<u>3.64</u>
<i>U. k. praekudarensis</i>	2	0.04		0.16	2.94	0.50	1.02	1.44	1.41	0.50	0.46
<i>U. k. kudarensis</i>	3	<u>4.23</u>	2.54		<u>3.94</u>	0.50	1.38	2.50	1.74	1.29	0.48
<i>U. rossicus</i>	4	3.21	2.10	<u>6.90</u>		<u>3.26</u>	1.61	2.00	0.91	3.20	<u>3.49</u>
<i>U. s. spelaeus</i>	5	2.06	1.38	1.32	<u>4.52</u>		1.41	1.90	1.75	1.07	0.09
<i>U. k. kanivetz</i>	6	0.93	0.56	2.81	<u>3.71</u>	1.12		0.07	0.48	0.82	1.45
<i>U. s. eremus</i>	7	1.48	0.98	1.89	<u>3.98</u>	0.49	0.60		0.50	1.45	2.07
<i>U. s. ladinicus</i>	8	0.24	0.20	<u>3.68</u>	2.46	1.98	1.00	1.48		1.27	1.79
<i>U. k. ingressus</i>	9	<u>5.35</u>	3.06	0.73	<u>8.04</u>	1.97	<u>3.64</u>	2.57	<u>4.48</u>		1.15
<i>U. arctos</i>	10	1.33	0.75	2.90	<u>4.36</u>	1.00	0.24	0.43	1.31	<u>3.90</u>	
		Bp									
<i>U. deningeri</i>	1		1.10	2.95	1.07	2.01	0.27	2.94	0.40	<u>4.11</u>	0.13
<i>U. k. praekudarensis</i>	2	1.03		0.87	1.66	0.94	0.52	1.35	0.29	2.07	1.09
<i>U. k. kudarensis</i>	3	2.39	2.62		2.40	0.45	1.25	0.93	0.85	2.15	2.43
<i>U. rossicus</i>	4	2.85	1.07	<u>4.93</u>		2.27	1.09	2.65	1.12	3.13	0.94
<i>U. s. spelaeus</i>	5	1.85	2.30	0.07	<u>4.08</u>		1.28	0.15	0.98	0.68	1.94
<i>U. k. kanivetz</i>	6	0.75	1.51	1.39	<u>3.28</u>	1.09		1.62	0.14	2.16	0.34
<i>U. s. eremus</i>	7	1.31	1.90	0.61	<u>3.58</u>	0.46	0.59		1.21	0.73	2.64
<i>U. s. ladinicus</i>	8	0.73	0.40	2.71	1.79	2.25	1.32	1.77		1.64	0.46
<i>U. k. ingressus</i>	9	2.51	2.79	0.59	<u>4.68</u>	0.57	1.71	1.03	2.83		<u>3.52</u>
<i>U. arctos</i>	10	<u>3.51</u>	1.29	<u>5.92</u>	0.19	<u>4.67</u>	<u>3.89</u>	<u>4.12</u>	2.16	<u>5.34</u>	
		Dp									
<i>U. deningeri</i>	1		2.65	<u>3.72</u>	0.82	1.87	0.20	2.28	1.43	<u>4.34</u>	0.26
<i>U. k. praekudarensis</i>	2	0.26		0.82	2.58	0.31	1.95	1.11	0.68	0.00	2.32
<i>U. k. kudarensis</i>	3	<u>4.39</u>	2.52		2.59	0.28	1.86	0.70	0.19	1.64	2.76
<i>U. rossicus</i>	4	2.69	2.06	<u>6.58</u>		2.07	0.83	2.10	1.73	3.12	0.94
<i>U. s. spelaeus</i>	5	1.71	1.15	1.07	<u>3.44</u>		1.43	0.57	0.34	0.38	1.64
<i>U. k. kanivetz</i>	6	0.73	0.24	3.26	3.14	1.16		1.31	1.06	2.52	0.01
<i>U. s. eremus</i>	7	2.64	1.63	0.95	<u>4.71</u>	0.30	1.86		0.14	1.78	1.77
<i>U. s. ladinicus</i>	8	1.38	0.73	2.32	<u>3.60</u>	0.62	0.66	1.15		0.82	1.22
<i>U. k. ingressus</i>	9	<u>3.48</u>	2.33	0.16	<u>5.37</u>	1.05	2.71	0.91	2.02		<u>3.49</u>
<i>U. arctos</i>	10	2.22	1.75	<u>6.12</u>	0.42	3.13	2.71	<u>4.31</u>	3.20	<u>5.00</u>	
		SD									
<i>U. deningeri</i>	1		1.68	<u>4.99</u>	0.23	<u>3.35</u>	0.46	2.69	0.01	<u>5.98</u>	0.21
<i>U. k. praekudarensis</i>	2	0.49		1.66	1.23	1.68	0.76	0.58	1.02	2.65	1.31
<i>U. k. kudarensis</i>	3	2.11	1.86		2.39	0.71	2.11	1.21	2.15	2.03	<u>3.60</u>
<i>U. rossicus</i>	4	1.76	0.78	<u>3.55</u>		2.42	0.51	1.68	0.17	3.01	0.34
<i>U. s. spelaeus</i>	5	2.96	2.61	1.29	<u>4.12</u>		2.13	1.33	2.22	0.22	2.90
<i>U. k. kanivetz</i>	6	2.50	2.20	0.64	<u>3.79</u>	0.66		1.27	0.32	2.85	0.28
<i>U. s. eremus</i>	7	1.81	1.76	0.14	3.08	0.98	0.40		1.46	2.43	2.09
<i>U. s. ladinicus</i>	8	0.08	0.50	1.63	1.56	2.50	2.04	1.50		2.78	0.13
<i>U. k. ingressus</i>	9	<u>4.27</u>	3.17	2.00	5.39	0.21	1.07	1.40	<u>3.29</u>		<u>4.54</u>
<i>U. arctos</i>	10	<u>3.75</u>	1.94	<u>5.80</u>	1.46	<u>5.88</u>	<u>5.76</u>	<u>4.73</u>	3.11	<u>8.14</u>	
		Bd									

Taxa		1	2	3	4	5	6	7	8	9	10
<i>U. deningeri</i>	1		1.96	<u>4.59</u>	0.75	2.48	0.75	2.97	0.40	<u>4.44</u>	0.36
<i>U. k. praekudarensis</i>	2	0.14		1.25	2.22	0.71	0.72	0.59	0.84	1.39	2.04
<i>U. k. kudarensis</i>	3	<u>3.81</u>	2.45		<u>3.79</u>	0.17	1.76	0.69	1.70	0.37	<u>3.97</u>
<i>U. rossicus</i>	4	2.77	1.65	<u>6.13</u>		2.67	1.21	2.93	0.86	<u>3.81</u>	0.39
<i>U. s. spelaeus</i>	5	2.44	1.85	0.48	<u>4.46</u>		1.26	0.26	1.32	0.33	2.53
<i>U. k. kanivetz</i>	6	2.09	1.49	1.28	<u>4.38</u>	0.59		1.23	0.20	1.86	0.95
<i>U. s. eremus</i>	7	2.79	2.06	0.25	<u>4.84</u>	0.21	0.84		1.28	0.88	2.87
<i>U. s. ladinicus</i>	8	0.35	0.37	2.74	2.65	1.85	1.43	2.12		1.79	0.60
<i>U. k. ingressus</i>	9	3.25	2.04	0.79	<u>5.72</u>	0.10	0.65	0.36	2.21		<u>3.96</u>
<i>U. arctos</i>	10	<u>3.59</u>	2.02	<u>7.28</u>	0.45	<u>5.13</u>	<u>5.20</u>	<u>5.58</u>	3.25	<u>6.94</u>	
				Dd							
<i>U. deningeri</i>	1		2.66	<u>4.24</u>	0.97	0.53	0.14	1.73	0.47	2.12	0.69
<i>U. k. praekudarensis</i>	2	0.11		0.02	2.64	0.82	2.13	1.25	1.31	1.29	3.00
<i>U. k. kudarensis</i>	3	<u>3.42</u>	1.99		3.07	0.90	2.63	2.00	1.53	<u>2.50</u>	<u>4.22</u>
<i>U. rossicus</i>	4	<u>3.85</u>	2.73	<u>6.62</u>		1.07	0.72	1.97	1.11	2.12	0.48
<i>U. s. spelaeus</i>	5	1.87	1.38	0.23	<u>4.35</u>		0.57	0.21	0.16	0.25	0.85
<i>U. k. kanivetz</i>	6	0.03	0.08	2.85	<u>3.43</u>	1.72		1.32	0.50	1.47	0.37
<i>U. s. eremus</i>	7	1.76	1.13	0.97	<u>4.79</u>	0.47	1.54		0.53	0.11	2.19
<i>U. s. ladinicus</i>	8	0.77	0.62	<u>3.57</u>	2.66	2.25	0.71	2.19		0.61	0.88
<i>U. k. ingressus</i>	9	0.52	0.23	2.68	<u>4.11</u>	1.49	0.41	1.26	1.17		2.53
<i>U. arctos</i>	10	<u>3.50</u>	2.43	<u>6.43</u>	0.48	<u>4.09</u>	3.09	<u>4.51</u>	2.30	<u>3.78</u>	

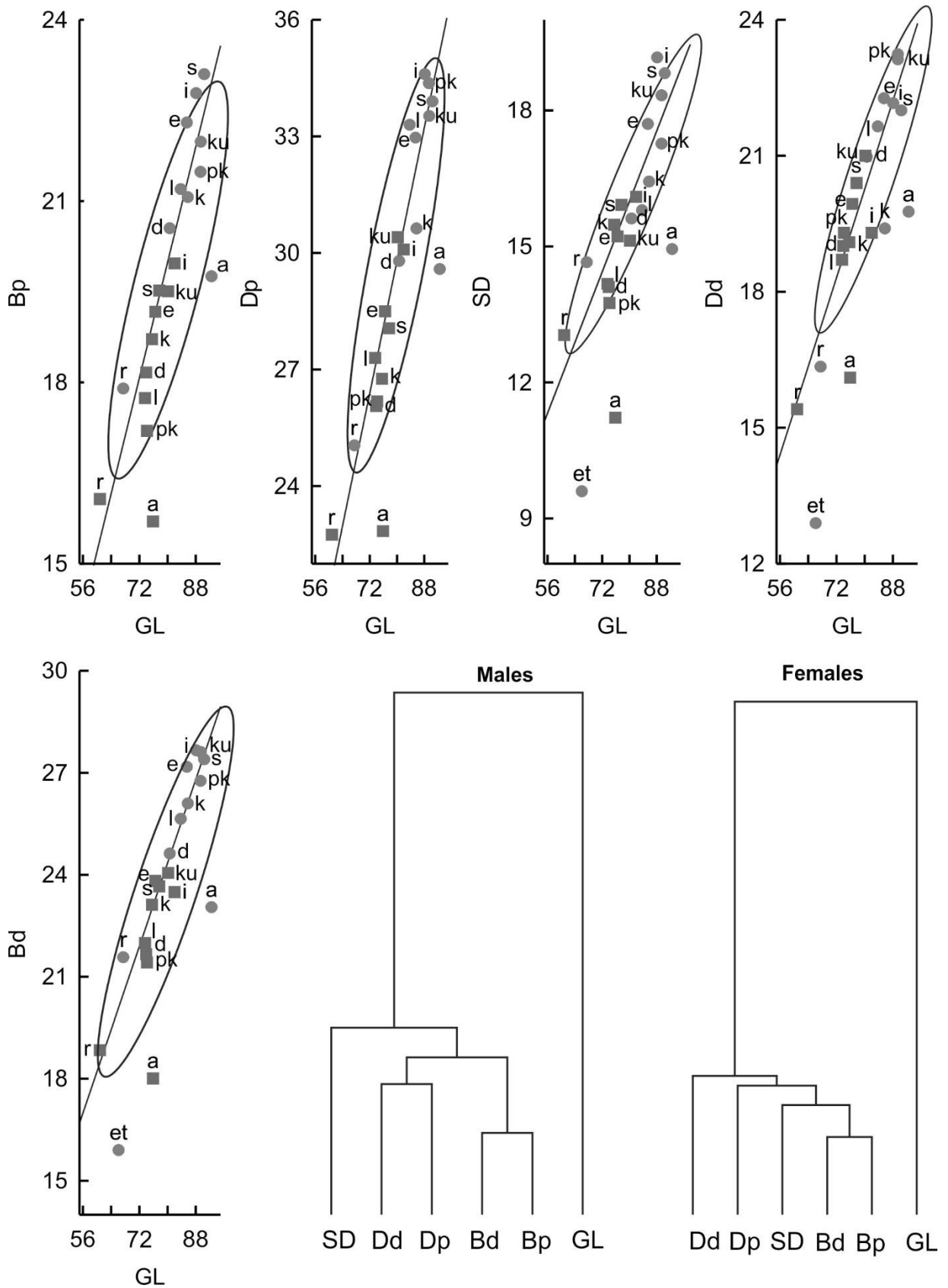

Fig. S11. The scatterplots of length of mtc III and the other measures (Bp – Dd) and Relationships between measures of mtc II (single linkage, correlation distances used): et – *U. etruscus*, a – *U. arctos*, r – *U. rossicus*, d – *U. deningeri*, pk – *U. k. praekudarensis*, ku – *U. k. kudarensis*, s – *U. s. spelaeus*, k – *U. k. kanivetz*, i – *U. k. ingressus*, e – *U. s. eremus*, l – *U. s. ladinicus*. The dashed lines are lines of regressions and ellipses' horizontal and vertical projections onto the axes are equal to the “sample mean ± “sample range” x 0.95.

Table S18. Statistical parameters of measures of mtc III among different bears and sexes: m – males, f – females.

Taxa	Sex	GL - N	GL	Std.Dev.	BP - N	BP	Std.Dev.	Dp- N	Dp	Std.Dev.	SD - N	SD	Std.Dev.	Bd - N	Bd	Std.Dev.	Dd- N	Dd	Std.Dev.
<i>U. etruscus</i>	f	1	66.1								1	9.6		1	15.9	0.00	1	12.9	
<i>U. rossicus</i>	m	4	67.5	3.43	2	17.9	1.98	2	25.1	1.77	2	14.7	1.63	4	21.6	1.65	2	16.4	0.07
	f	15	60.9	2.48	13	16.1	1.42	13	22.7	1.03	13	13.0	0.72	15	18.8	0.91	11	15.4	0.93
<i>U. deningeri</i>	m	11	80.6	3.57	13	20.6	1.27	11	29.8	2.51	13	15.6	0.85	11	24.6	1.05	10	21.0	1.14
	f	22	73.5	2.90	21	18.2	1.39	20	26.1	1.83	22	14.2	1.03	22	21.7	1.16	21	19.0	1.13
<i>U. k. praekudar.</i>	m	5	89.4	4.73	6	21.5	0.77	3	34.4	0.97	6	17.3	1.18	6	26.8	1.13	5	23.2	1.58
	f	5	74.2	3.04	6	17.2	1.89	5	26.2	1.68	6	13.8	1.32	5	21.4	2.14	5	19.3	1.41
<i>U. k. kudarensis</i>	m	52	89.4	3.46	51	22.0	1.38	50	33.5	2.05	53	18.3	1.28	48	27.6	1.41	50	23.1	1.11
	f	20	80.2	3.58	21	19.5	1.46	20	30.4	2.58	22	15.1	1.49	21	24.1	1.89	21	21.0	1.50
<i>U. s. spelaeus</i>	m	4	90.4	2.52	4	23.1	2.89	2	33.9	1.84	4	18.8	0.68	4	27.4	1.28	1	22.0	0.00
	f	10	77.6	1.91	10	19.5	1.18	5	28.1	1.10	10	15.9	0.93	9	23.7	1.42	5	20.4	1.03
<i>U. k. kanivetz</i>	m	3	85.7	3.45	3	21.1	0.25	3	30.6	2.05	3	16.4	0.50	3	26.1	0.46	3	19.4	3.00
	f	14	75.6	2.51	14	18.7	0.91	14	26.8	1.52	14	15.5	1.13	14	23.1	1.00	12	19.1	0.84
<i>U. s. eremus</i>	m	10	85.4	3.64	10	22.3	0.72	10	33.0	1.46	10	17.7	1.20	10	27.2	1.16	10	22.3	1.09
	f	10	76.5	3.01	10	19.2	1.74	10	28.5	1.22	10	15.2	1.24	10	23.8	1.10	10	19.9	0.97
<i>U. s. ladinicus</i>	m	2	83.7	3.25	2	21.2	0.14	2	33.3	1.27	2	15.8	0.57	2	25.7	1.20	2	21.7	1.06
	f	11	73.6	2.70	11	17.7	0.98	11	27.3	1.11	11	14.2	0.80	11	22.0	0.96	11	18.7	0.71
<i>U. k. ingressus</i>	m	24	88.1	4.72	16	22.8	1.07	15	34.6	1.50	26	19.2	1.30	23	27.7	1.03	21	22.2	1.24
	f	28	82.0	4.02	10	20.0	1.08	8	30.1	1.93	28	16.1	1.10	27	23.5	1.17	17	19.3	0.87
<i>U. arctos</i>	m	6	92.5	7.43	7	19.8	2.26	7	29.6	3.56	7	14.9	2.16	6	23.1	2.44	6	19.8	1.56
	f	23	76.1	6.00	22	15.7	1.84	13	22.8	2.78	23	11.3	1.31	23	18.1	1.71	14	16.3	1.72

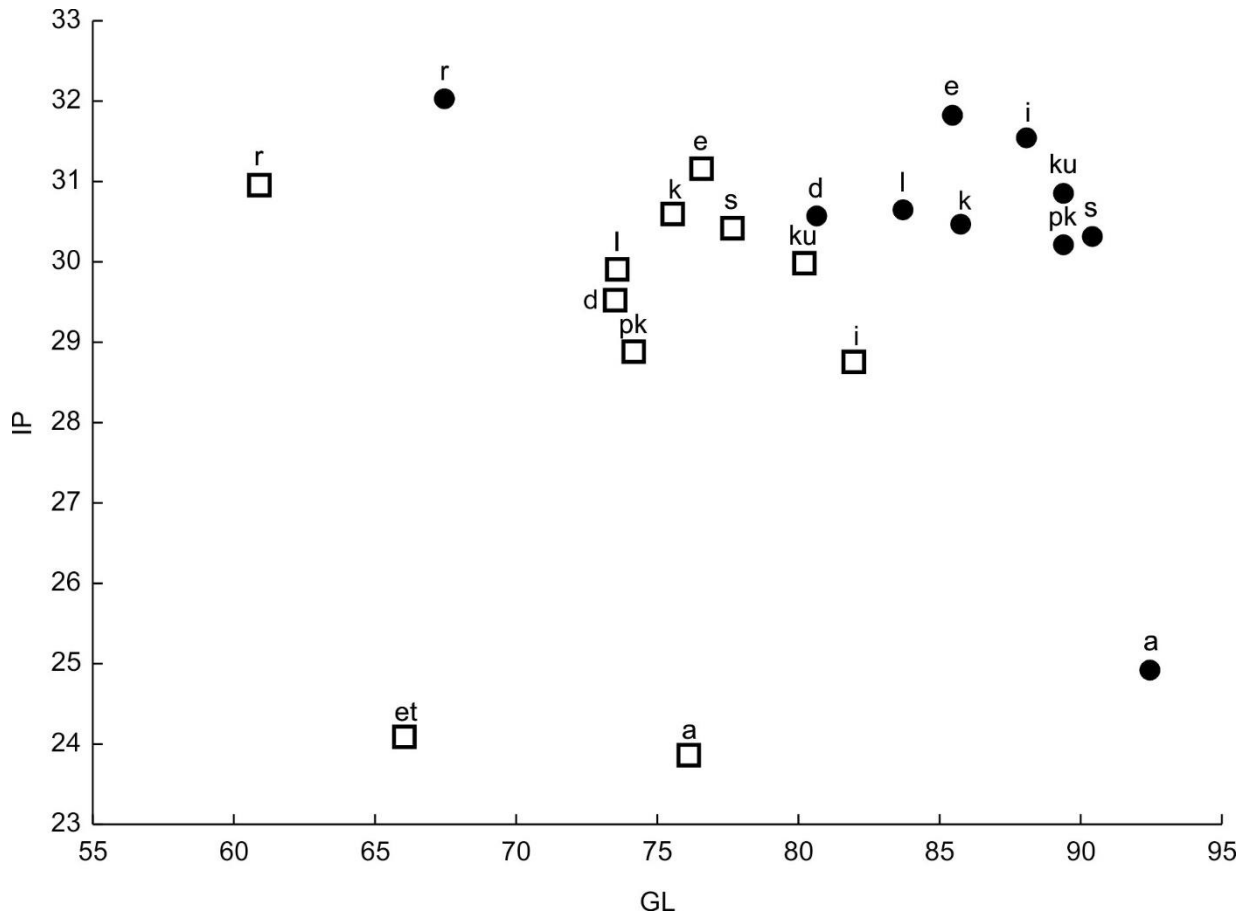

Fig. S12. The scatterplot of Index plumpness (ip) and GL of mtc III: a – *U. arctos*, r – *U. rossicus*, sa – *U. savini*, d – *U. deningeri*, pk – *U. k. praekudarensis*, ku – *U. k. kudarensis*, s – *U. s. spelaeus*, k – *U. k. kanivetz*, i – *U. k. ingressus*, e – *U. s. eremus*, l – *U. s. ladinicus*. Point – males, square – females.

### Multivariate analysis

Table S19. Description of the modeled morphological spaces for cave bears and brown bear mtc III. Correlation coefficients among the measures and dimensions of two morphospace models (MDS axes: E1–E2, K1–K2);  $r^2$  – coefficients of determination in the linear multiple regression models.

Measures	Morphospaces with <i>U. arctos</i>				$r^2$	Morphospaces without <i>U. arctos</i>					$r^2$
	“Size” morphospace		“Shape” morphospace			“Size” morphospace		“Shape” morphospace			
	E1	E2	K1	K2		E1	E2	K1	K2	K3	
GL	0.95	0.56	-0.13	0.49	0.96	0.95	0.16	-0.5	-0.25	0.28	0.97
Bp	0.91	0.24	0.07	0.32	0.87	0.92	0.04	-0.42	-0.1	-0.1	0.89
Dp	0.96	0.44	0.09	0.46	0.94	0.96	0.22	-0.6	-0.42	-0.08	0.97
SD	0.92	0.12	0.01	0.09	0.96	0.92	-0.22	-0.15	-0.37	-0.01	0.98
Bd	0.97	0.25	0.05	0.3	0.97	0.97	-0.02	-0.37	-0.31	-0.03	0.97
Dd	0.95	0.51	0.15	0.53	0.94	0.95	0.34	-0.58	-0.11	0.05	0.95
ip	0.30	-0.65	0.54	-0.26	0.87	0.29	-0.25	0.19	0.04	-0.70	0.69
Relative variance (%) of dimensions associated with taxonomical composition											
	59.4	31.9	17.6	36.8		59.8	29.3	37.4	39.5	9.6	



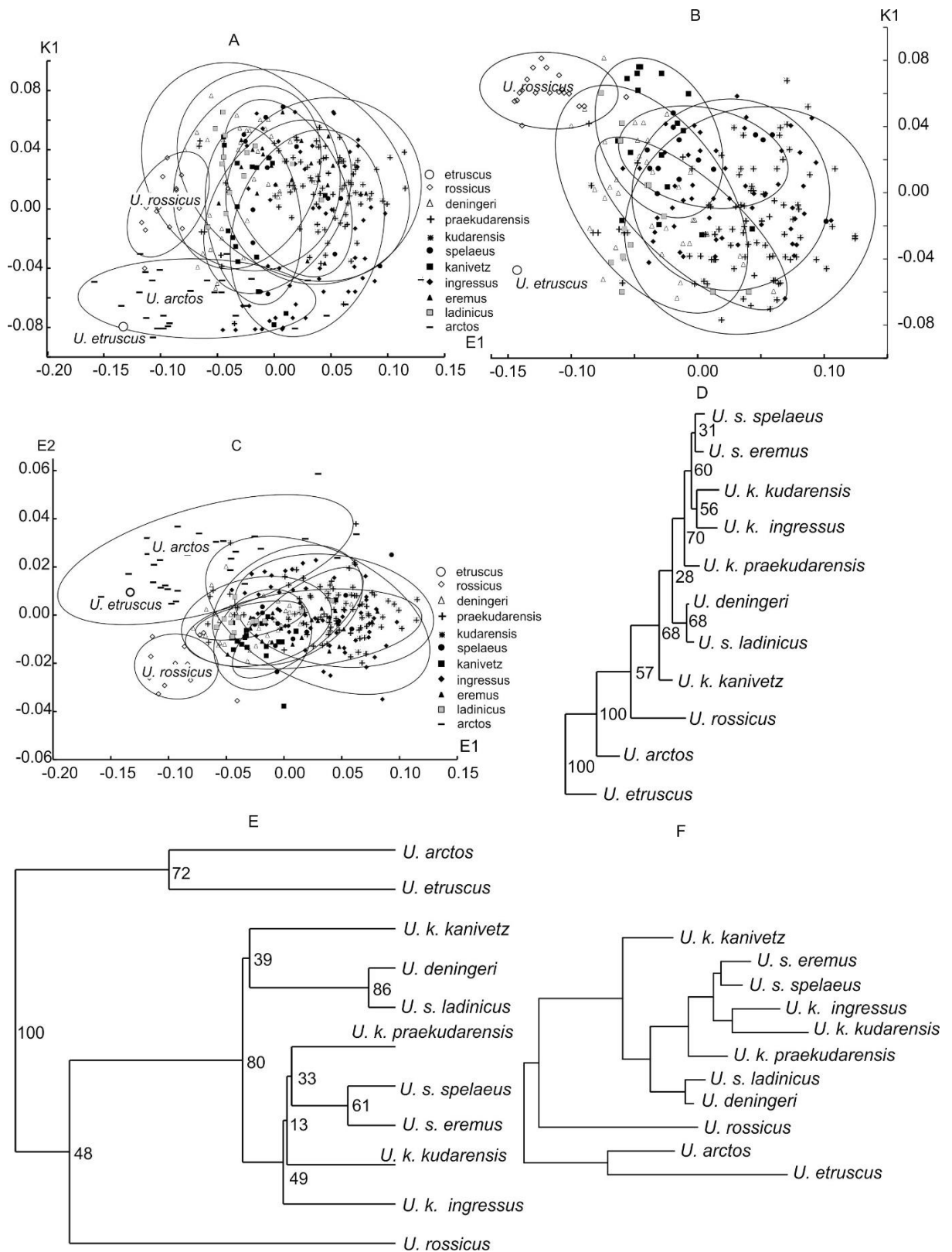

Fig. S13. Scatterplot of the first dimensions of "size" (E1) and "shape" (K1) morphospaces reproduced variation of mtc III in males and females: A, C – models with *U. arctos*; B – model without *U. arctos*; C – "size" morphospace; D – NJ tree; E – UGMA dendrogram (cophenetic correlation – 0.92); F – Sattath-Tversky (Sattath, Tversky, 1977) additive tree. All classifications based on the coordinates of samples' centroids in the "size" (E1, E2) and "shape" (K1, K2) morphospaces (numbers near the nodes - bootstrap (1000 repeats) supports in %). Ellipses' horizontal and vertical projection onto the E1 (E2) and K1 axes are equal to the "sample mean" (centroid)  $\pm$  "sample range"  $\times$  0.95.

## Males

Table S20. Description of the modeled morphological spaces for males of cave bears and brown bear mtc III. Correlation coefficients among the measures and dimensions of two morphospace models (MDS axes: E1–E2, K1–K2);  $r^2$  – coefficients of determination in the linear multiple regression models.

Measure s	Morphospaces with <i>U. arctos</i>					Morphospaces without <i>U. arctos</i>					
	“Size”		“Shape”			$r^2$	“Size”		“Shape”		$r^2$
	morphospace		morphospace		morphospace		morphospace				
E1	K1	K2	K3	E1	K1	K2	K3				
GL	0.70	-0.35	0.06	0.53	0.84	0.88	-0.26	0.08	-0.61	0.95	
Bp	0.83	-0.20	-0.43	-0.27	0.78	0.79	-0.29	-0.10	0.08	0.75	
Dp	0.94	-0.42	-0.60	0.11	0.96	0.94	-0.57	-0.38	-0.27	0.96	
SD	0.84	0.19	-0.48	0.03	0.92	0.83	0.08	-0.39	-0.27	0.93	
Bd	0.90	0.03	-0.49	-0.07	0.89	0.89	-0.08	-0.26	-0.17	0.89	
Dd	0.89	-0.45	-0.37	-0.10	0.87	0.87	-0.57	-0.06	-0.13	0.88	
ip	0.20	0.37	-0.44	-0.53	0.72	0.19	0.22	-0.40	0.64	0.67	
Relative variance (%) of dimensions associated with taxonomical composition											
	75.1	25.3	36.9	28.2		77.2	22.6	33.9	19.2		

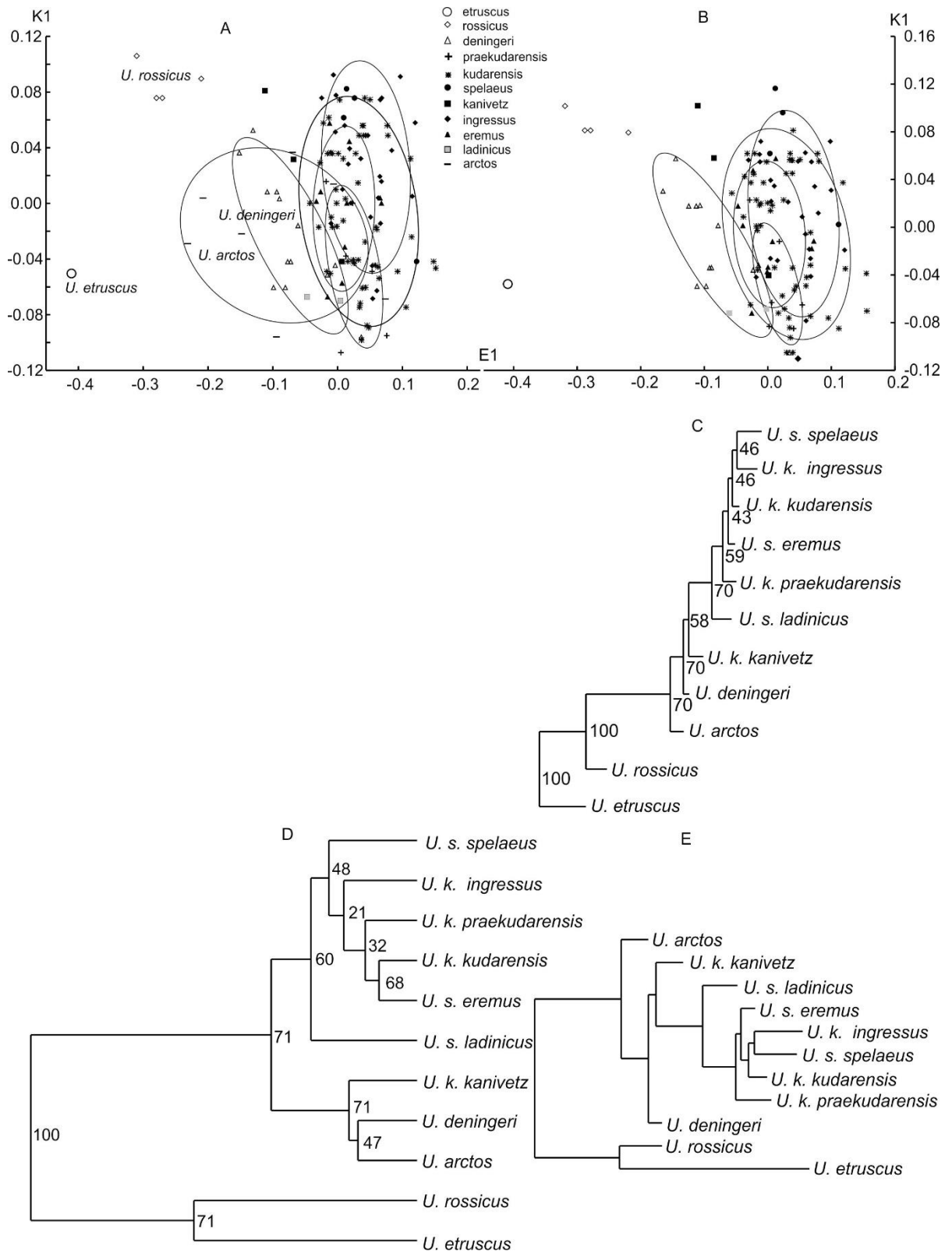

Fig. S14. Scatterplot of the first dimensions of “size” (E1) and “shape” (K1) morphospaces reproduced variation of mtc III in males: A, C – models with *U. arctos*; B – model without *U. arctos*; C – “size” morphospace; C – “size” morphospace; D – NJ tree; E – UGMA dendrogram (cophenetic correlation – 0.92); F – Sattath-Tversky (Sattath, Tversky, 1977) additive tree. All classifications based on the coordinates of samples’ centroids in the “size” (E1, E2) and “shape” (K1, K2) morphospaces (numbers near the nodes - bootstrap (1000 repeats) supports in %). Ellipses’ horizontal and vertical projection onto the E1 (E2) and K1 axes are equal to the “sample mean” (centroid)  $\pm$  “sample range” x 0.95.

## Females

Table S21. Description of the modeled morphological spaces for females of cave bears and brown bear mtc III. Correlation coefficients among the measures and dimensions of two morphospace models (MDS axes: E1–E2, K1–K2);  $r^2$  – coefficients of determination in the linear multiple regression models.

Measures	Morphospaces with <i>U. arctos</i>					Morphospaces without <i>U. arctos</i>						
	“Size”		“Shape”			$r^2$	“Size”		“Shape”			$r^2$
	morphospace		morphospace				morpho- space		morphospace			
	E1	E2	K1	K2		E1	K1	K2	K3	K4		
GL	0.71	0.53	-0.20	-0.41	0.94	0.88	-0.18	-0.06	0.24	-0.03	0.89	
Bp	0.89	-0.20	0.31	-0.28	0.82	0.85	-0.02	-0.44	-0.21	0.37	0.94	
Dp	0.93	-0.10	0.33	-0.44	0.86	0.90	-0.20	0.10	0.25	0.44	0.95	
SD	0.88	-0.49	0.67	-0.09	0.94	0.85	0.44	-0.26	0.34	0.14	0.94	
Bd	0.96	-0.31	0.53	-0.36	0.95	0.95	0.05	-0.21	0.45	0.27	0.96	
Dd	0.95	-0.08	0.33	-0.60	0.95	0.92	-0.24	-0.18	0.25	0.07	0.92	
ip	0.08	-0.73	0.72	-0.18	0.89	0.09	0.13	-0.49	0.53	0.51	0.78	
Relative variance (%) of dimensions associated with taxonomical composition												
	74.8	65.9	54.8	46.5		71.2	37.4	20.1	5.7	10.7		

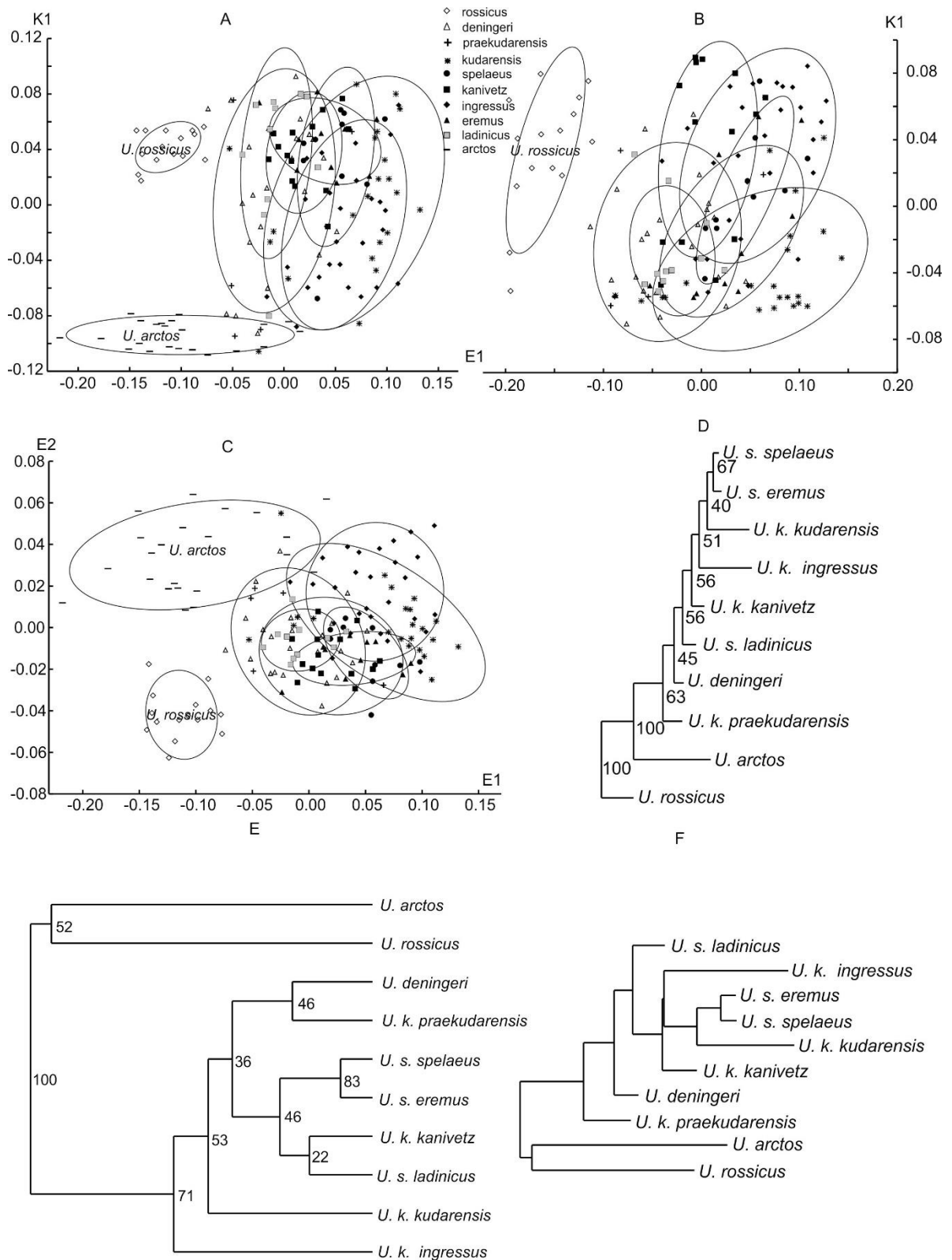

Fig. S15. Scatterplot of the first dimensions of “size” (E1) and “shape” (K1) morphospaces reproduced variation of mtc III in females: A, C – models with *U. arctos*; B – model without *U. arctos*; C – “size” morphospace; D – NJ tree; E – UGMA dendrogram (cophenetic correlation – 0.92); F – Sattath-Tversky (Sattath, Tversky, 1977) additive tree. All classifications based on the coordinates of samples’ centroids in the “size” (E1, E2) and “shape” (K1, K2) morphospaces (numbers near the nodes - bootstrap (1000 repeats) supports in %). Ellipses’ horizontal and vertical projection onto the E1 (E2) and K1 axes are equal to the “sample mean” (centroid) ± “sample range” x 0.95.

**METACARPAL BONE IV (MTC IV)****Males and females**

Table S22. Sample numbers (N), means (M), and standard errors (m) of the variables of mtc IV among the different forms of bears

Form	GL		Bp		Dp		SD	
	N	M±m	N	M±m	N	M±m	N	M±m
<i>U. deningeri</i>	37	79.4±0.93	37	21.0±0.33	37	29.2±0.47	37	16.3±0.22
<i>U. k. praekudarensis</i>	6	82.4±3.45	8	18.2±0.89	6	29.1±1.58	8	14.9±0.71
<i>U. k. kudarensis</i>	48	89.9±0.98	53	24.1±0.32	51	34.1±0.46	54	18.4±0.26
<i>U. rossicus</i>	26	63.2±0.70	20	17.1±0.23	19	23.3±0.35	20	14.0±0.24
<i>U. s. spelaeus</i>	28	81.4±0.98	27	21.7±0.30	24	30.1±0.47	28	17.4±0.30
<i>U. k. kanivetz</i>	18	80.1±1.30	18	21.1±0.46	17	29.4±0.71	18	17.8±0.30
<i>U. s. eremus</i>	20	82.6±1.01	20	22.2±0.33	20	32.4±0.44	20	16.8±0.31
<i>U. s. ladinicus</i>	10	77.0±1.39	10	21.2±0.39	10	30.2±0.59	10	16.0±0.33
<i>U. k. ingressus</i>	45	88.5±0.71	14	24.3±0.59	11	35.6±0.76	47	18.5±0.23
<i>U. arctos</i>	27	80.5±1.87	27	17.6±0.58	21	24.5±0.78	27	12.6±0.38
			Bd		Dd			
			N	M±m	N	M±m		
<i>U. deningeri</i>			36	24.9±0.35	36	20.8±0.23		
<i>U. k. praekudarensis</i>			7	24.3±1.28	5	21.3±1.31		
<i>U. k. kudarensis</i>			51	28.1±0.40	46	22.9±0.28		
<i>U. rossicus</i>			26	20.2±0.23	17	16.0±0.27		
<i>U. s. spelaeus</i>			28	25.3±0.40	18	20.6±0.28		
<i>U. k. kanivetz</i>			18	25.8±0.50	10	21.0±0.44		
<i>U. s. eremus</i>			20	26.0±0.48	20	21.3±0.37		
<i>U. s. ladinicus</i>			10	24.2±0.54	10	20.0±0.36		
<i>U. k. ingressus</i>			45	27.2±0.37	30	22.8±0.20		
<i>U. arctos</i>			27	19.2±0.54	21	17.4±0.52		

**Sexual dimorphism**Table S23. Sexual size dimorphism (SSD and ASSD) of mtc IV in the different forms of cave bears and brown bear; *p* based on Mann-Whitney U Test; *v*, % - relative variance associated with SSD.

	SSD						ASS D
	GL	Bp	Dp	SD	Bd	Dd	
	<i>U. deningeri</i>						
Males	85.8±1.11	22.5±0.49	31.7±0.43	17.6±0.24	26.6±0.36	22.1±0.25	
Females	76.0±0.54	20.2±0.33	27.8±0.56	15.5±0.19	24.0±0.39	20.0±0.20	
SSD	6.0±0.76	5.5±1.38	6.5±1.10	6.3±0.92	5.0±1.06	5.0±0.76	
	(<0.001)	(<0.001)	(<0.001)	(<0.001)	(<0.001)	(<0.001)	5.74
<i>v</i> , %	81.8	47.4	59.0	71.3	51.1	71.2	
	<i>U. rossicus</i>						
Males	66.4±0.82	17.8±0.24	24.4±0.28	14.6±0.39	21.0±0.22	16.8±0.31	
Females	60.9±0.51	16.6±0.25	22.6±0.24	13.6±0.25	16.8±0.28	15.4±0.30	
SSD	4.3±0.76	3.5±1.00	3.9±0.78	3.6±1.63	3.5±0.87	4.1±1.33	
	(<0.001)	(0.005)	(<0.001)	(0.03)	(0.002)	(0.01)	3.83
<i>v</i> , %	66.5	50.7	75.1	48.0	44.6	57.5	
	<i>U. k. praekudarensis</i>						



## Univariate analysis

Table S24. Kruskal-Wallis test z' values (males - above diagonal and females – under diagonal) for measures of mtc IV. The statistical significance values, according to 2-tailed *p* values, have been underlined.

Taxa		1	2	3	4	5	6	7	8	9	10
		GL									
<i>U. deningeri</i>	1		0.76	<u>4.14</u>	2.56	1.64	0.63	2.52	0.08	1.33	0.99
<i>U. k. praekudarensis</i>	2	0.24		1.46	2.36	0.45	0.21	0.75	0.68	1.63	0.11
<i>U. k. kudarensis</i>	3	<u>3.60</u>	2.06		<u>6.89</u>	1.26	2.15	1.24	<u>3.53</u>	<u>4.29</u>	2.62
<i>U. rossicus</i>	4	<u>3.32</u>	1.49	6.30		<u>3.66</u>	2.56	<u>5.00</u>	2.41	0.65	<u>3.35</u>
<i>U. s. spelaeus</i>	5	2.04	1.22	1.67	<u>5.06</u>		0.79	0.33	1.47	2.49	0.76
<i>U. k. kanivetz</i>	6	0.70	0.61	2.44	<u>3.52</u>	1.03		1.22	0.53	1.63	0.16
<i>U. k. ingressus</i>	7	<u>6.07</u>	2.98	1.69	<u>8.72</u>	<u>3.76</u>	<u>4.26</u>		2.19	3.20	1.33
<i>U. s. eremus</i>	8	1.85	1.26	1.20	<u>4.45</u>	0.20	1.06	2.78		1.31	0.83
<i>U. s. ladinicus</i>	9	1.06	0.51	3.27	1.10	2.27	1.45	<u>4.51</u>	2.22		2.04
<i>U. arctos</i>	10	0.12	0.18	<u>3.44</u>	2.98	1.99	0.76	<u>5.59</u>	1.84	0.95	
		Bp									
<i>U. deningeri</i>	1		1.07	3.05	2.73	0.73	1.01	2.93	0.60	0.94	1.38
<i>U. k. praekudarensis</i>	2	2.57		2.79	0.80	1.48	1.67	2.94	1.41	0.26	0.16
<i>U. k. kudarensis</i>	3	<u>3.27</u>	<u>4.51</u>		<u>5.64</u>	1.44	0.97	0.73	1.97	3.11	<u>4.38</u>
<i>U. rossicus</i>	4	<u>3.40</u>	0.12	<u>6.00</u>		2.93	3.08	<u>5.14</u>	3.05	1.28	1.36
<i>U. s. spelaeus</i>	5	1.77	<u>3.61</u>	1.47	<u>4.79</u>		0.29	1.73	0.19	1.41	1.82
<i>U. k. kanivetz</i>	6	0.24	2.24	3.01	2.79	1.74		1.33	0.49	1.62	2.03
<i>U. k. ingressus</i>	7	1.65	<u>3.28</u>	0.36	<u>3.78</u>	0.56	1.70		2.15	3.17	<u>4.03</u>
<i>U. s. eremus</i>	8	1.56	<u>3.40</u>	1.12	<u>4.24</u>	0.10	1.59	0.45		1.35	1.83
<i>U. s. ladinicus</i>	9	0.61	2.47	1.38	2.82	0.46	0.73	0.80	0.50		0.16
<i>U. arctos</i>	10	<u>4.14</u>	0.10	<u>6.98</u>	0.30	<u>5.65</u>	<u>3.34</u>	<u>4.17</u>	<u>4.86</u>	3.17	
		Dp									
<i>U. deningeri</i>	1		1.06	<u>4.00</u>	2.15	0.53	0.66	<u>3.68</u>	2.00	0.13	1.49
<i>U. k. praekudarensis</i>	2	0.62		<u>0.69</u>	2.26	0.67	0.55	1.07	0.08	1.05	1.86
<i>U. k. kudarensis</i>	3	<u>3.37</u>	2.50		<u>5.57</u>	2.36	2.00	0.88	1.18	2.87	<u>5.20</u>
<i>U. rossicus</i>	4	<u>3.44</u>	1.53	<u>6.08</u>		2.28	2.32	<u>5.14</u>	<u>3.72</u>	1.60	0.72
<i>U. s. spelaeus</i>	5	1.49	1.44	1.76	<u>4.51</u>		0.15	2.58	1.15	0.54	1.72
<i>U. k. kanivetz</i>	6	0.16	0.67	2.67	3.12	1.09		2.29	0.93	0.66	1.78
<i>U. k. ingressus</i>	7	2.55	2.48	0.82	4.31	1.76	2.33		1.62	3.02	<u>4.73</u>
<i>U. s. eremus</i>	8	2.77	2.30	0.11	5.33	1.42	2.28	0.85		1.68	3.21
<i>U. s. ladinicus</i>	9	0.94	1.19	1.16	3.16	0.00	0.77	1.50	1.01		1.03
<i>U. arctos</i>	10	<u>3.50</u>	1.57	<u>6.14</u>	0.05	<u>4.57</u>	3.17	<u>4.34</u>	<u>5.38</u>	3.20	
		SD									
<i>U. deningeri</i>	1		0.65	2.44	2.19	2.29	2.15	<u>3.99</u>	0.28	1.07	2.29
<i>U. k. praekudarensis</i>	2	1.21		2.01	0.84	2.18	2.12	3.07	0.81	0.20	0.83
<i>U. k. kudarensis</i>	3	<u>3.31</u>	3.19		<u>4.53</u>	0.75	0.70	2.33	1.80	2.84	<u>4.89</u>
<i>U. rossicus</i>	4	2.06	0.25	<u>4.74</u>		<u>3.91</u>	<u>3.71</u>	<u>5.68</u>	2.27	0.74	0.04
<i>U. s. spelaeus</i>	5	2.54	2.71	0.82	<u>4.12</u>		0.00	0.84	1.91	2.79	<u>4.05</u>
<i>U. k. kanivetz</i>	6	2.95	3.06	0.04	<u>4.36</u>	0.76		0.78	1.81	2.67	<u>3.82</u>
<i>U. k. ingressus</i>	7	<u>4.84</u>	<u>3.95</u>	1.05	<u>6.02</u>	2.00	0.87		<u>3.31</u>	<u>4.03</u>	<u>6.04</u>
<i>U. s. eremus</i>	8	0.48	1.43	2.20	2.16	1.56	2.05	3.23		1.22	2.36
<i>U. s. ladinicus</i>	9	0.04	0.97	1.96	1.41	1.47	1.89	2.66	0.28		0.73
<i>U. arctos</i>	10	<u>3.52</u>	1.03	<u>6.42</u>	1.03	<u>5.78</u>	<u>5.79</u>	<u>8.10</u>	<u>3.34</u>	2.24	
		Bd									



Taxa		1	2	3	4	5	6	7	8	9	10
<i>U. deningeri</i>	1		0.45	3.12	2.52	1.43	1.55	<u>3.74</u>	1.40	0.79	1.90
<i>U. k. praekudarensis</i>	2	1.05		1.22	2.03	0.59	0.72	1.81	0.48	0.96	1.65
<i>U. k. kudarensis</i>	3	3.04	2.75		<u>5.89</u>	0.72	0.43	1.29	1.11	3.00	<u>5.04</u>
<i>U. rossicus</i>	4	<u>3.59</u>	1.10	<u>6.17</u>		<u>3.42</u>	<u>3.43</u>	<u>6.14</u>	<u>3.65</u>	1.15	0.54
<i>U. s. spelaeus</i>	5	0.76	1.47	2.28	<u>4.23</u>		0.19	1.51	0.19	1.85	2.91
<i>U. k. kanivetz</i>	6	1.06	1.64	1.59	<u>4.11</u>	0.41		1.19	0.38	1.95	2.95
<i>U. k. ingressus</i>	7	3.21	2.74	0.20	<u>6.59</u>	2.36	1.56		1.95	3.56	5.40
<i>U. s. eremus</i>	8	0.40	1.23	2.09	<u>3.37</u>	0.21	0.54	2.10		1.83	3.06
<i>U. s. ladinicus</i>	9	0.33	0.61	2.20	1.99	0.79	1.01	2.17	0.58		0.70
<i>U. arctos</i>	10	<u>4.32</u>	1.46	<u>6.96</u>	0.54	<u>4.98</u>	<u>4.75</u>	<u>7.51</u>	<u>3.95</u>	2.40	
				Dd							
<i>U. deningeri</i>	1		1.90	3.04	2.81	0.07	0.24	2.07	0.94	1.40	2.01
<i>U. k. praekudarensis</i>	2	0.44		0.58	<u>3.44</u>	1.63	1.51	0.81	1.33	2.61	2.96
<i>U. k. kudarensis</i>	3	2.60	1.74		<u>5.53</u>	1.75	1.65	0.55	1.60	<u>3.62</u>	<u>5.07</u>
<i>U. rossicus</i>	4	<u>3.54</u>	1.63	<u>5.48</u>		1.84	2.32	<u>4.51</u>	<u>3.42</u>	0.99	0.95
<i>U. s. spelaeus</i>	5	0.68	0.78	1.69	<u>3.84</u>		0.24	1.35	0.68	0.95	1.22
<i>U. k. kanivetz</i>	6	0.28	0.56	1.47	2.85	0.20		1.20	0.45	1.31	1.67
<i>U. k. ingressus</i>	7	<u>3.93</u>	2.41	1.26	<u>6.54</u>	2.89	2.35		0.96	2.94	<u>3.91</u>
<i>U. s. eremus</i>	8	0.23	0.54	1.92	<u>3.26</u>	0.36	0.09	3.01		2.05	2.73
<i>U. s. ladinicus</i>	9	0.56	0.01	2.17	1.94	0.98	0.67	3.00	0.67		0.20
<i>U. arctos</i>	10	<u>3.55</u>	1.59	<u>5.54</u>	0.09	<u>3.85</u>	2.81	<u>6.63</u>	3.25	1.90	

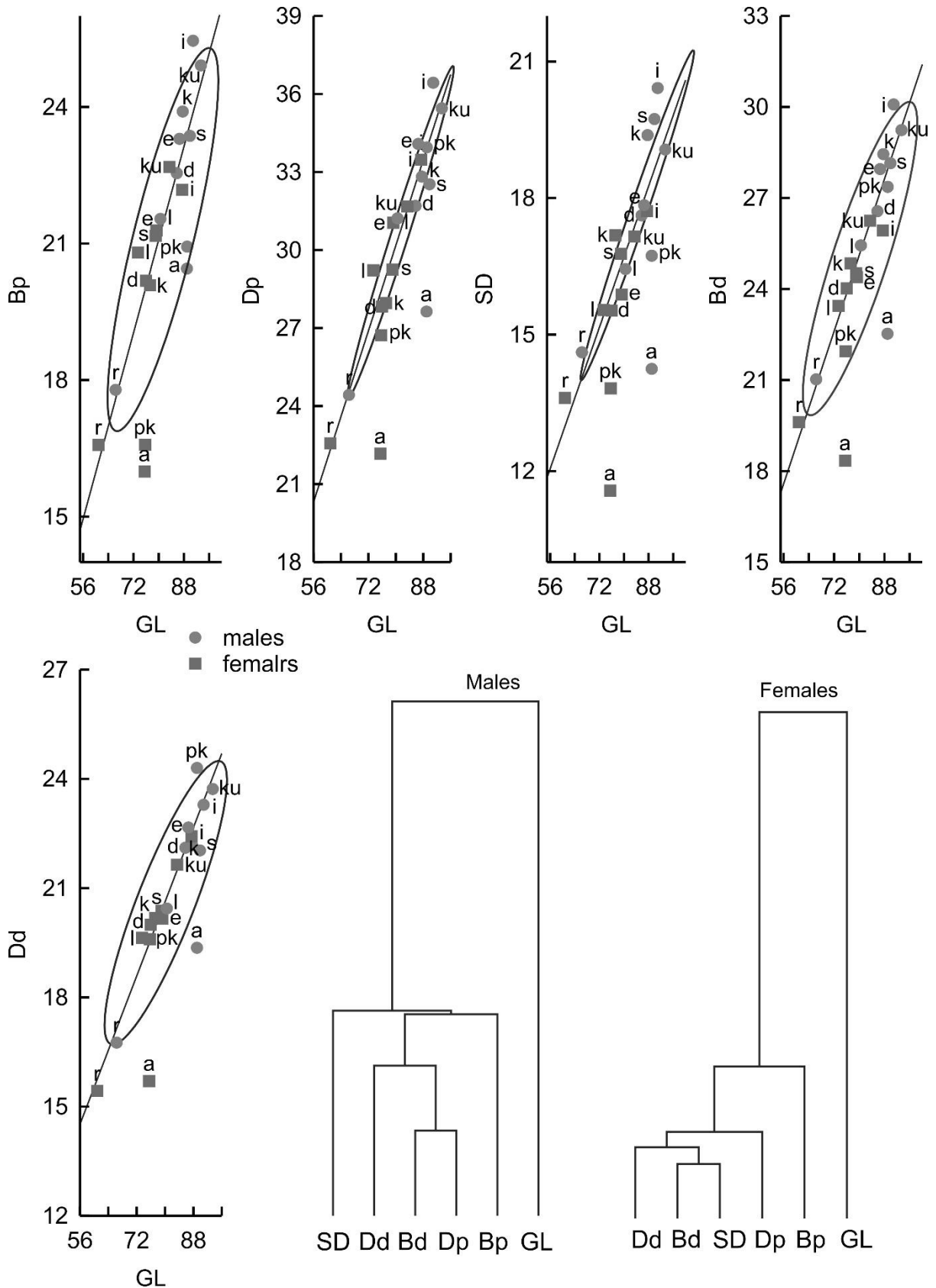

Fig. S16. The scatterplots of length of mtc IV and the other measures (BP – DD) and Relationships between measures of mtc IV (single linkage, correlation distances used): et – *U. etruscus*, a – *U. arctos*, r – *U. rossicus*, d – *U. deningeri*, pk – *U. k. praekudarensis*, ku – *U. k. kudarensis*, s – *U. s. spelaeus*, k – *U. k. kanivetz*, i – *U. k. ingressus*, e – *U. s. eremus*, l – *U. s. ladinicus*. The dashed lines are lines of regressions and ellipses' horizontal and vertical projections onto the axes are equal to the "sample mean ± "sample range" x 0.95

Table S25. Statistical parameters of measures of mtc IV among different bears and sexes: m – males, f – females.

Taxa	Sex	GL - N	GL	Std.Dev.	BP - N	BP	Std.Dev.	Dp- N	Dp	Std.Dev.	SD - N	SD	Std.Dev.	Bd - N	Bd	Std.Dev.	Dd- N	Dd	Std.Dev.
<i>U. rossicus</i>	f	15	60.9	1.99	12	16.6	0.86	12	22.6	0.83	12	13.6	0.85	15	19.6	1.09	10	15.4	0.94
	m	11	66.4	2.71	8	17.8	0.67	7	24.4	0.73	8	14.6	1.10	11	21.0	0.72	7	16.8	0.81
<i>U. deningeri</i>	f	24	76.0	2.65	24	20.2	1.61	24	27.8	2.45	24	15.5	0.94	23	24.0	1.89	23	20.0	0.97
	m	13	85.8	4.00	13	22.5	1.77	13	31.7	1.55	13	17.6	0.85	13	26.6	1.31	13	22.1	0.89
<i>U. k. praekudar.</i>	f	3	75.7	1.21	5	16.6	1.41	4	26.7	1.19	5	13.8	1.58	4	22.0	2.31	3	19.6	1.82
	m	3	89.0	6.64	3	20.9	0.60	2	34.0	0.92	3	16.7	1.10	3	27.4	1.08	2	24.3	0.99
<i>U. k. kudarensis</i>	f	17	83.4	5.59	20	22.7	2.45	18	31.7	3.27	20	17.2	1.99	19	26.3	2.76	18	21.6	1.95
	m	31	93.4	4.29	33	24.9	1.82	33	35.4	2.49	34	19.1	1.43	32	29.2	2.29	28	23.7	1.35
<i>U. s. spelaeus</i>	f	22	79.0	2.43	21	21.2	1.01	18	29.3	1.83	22	16.8	0.83	22	24.5	1.30	15	20.4	1.03
	m	6	89.9	3.03	6	23.4	1.92	6	32.5	1.73	6	19.7	1.59	6	28.2	2.15	3	22.0	1.10
<i>U. k. kanivetz</i>	f	13	77.2	3.04	13	20.1	0.77	12	28.0	2.08	13	17.2	0.82	13	24.8	1.37	6	20.2	0.64
	m	5	87.6	1.61	5	23.9	1.08	5	32.8	1.33	5	19.4	0.59	5	28.4	1.36	4	22.2	1.40
<i>U. s. eremus</i>	f	11	79.3	2.62	11	21.3	1.01	11	31.0	1.47	11	15.9	1.02	11	24.4	1.16	11	20.2	1.06
	m	9	86.6	2.67	9	23.3	1.13	9	34.1	0.95	9	17.8	0.95	9	28.0	1.15	9	22.7	1.09
<i>U. s. ladinicus</i>	f	5	73.5	2.18	5	20.8	1.55	5	29.2	0.47	5	15.5	1.17	5	23.4	1.84	5	19.6	1.32
	m	5	80.5	2.74	5	21.5	0.86	5	31.2	2.25	5	16.4	0.78	5	25.4	0.87	5	20.4	0.91
<i>U. k. ingressus</i>	f	31	87.4	4.82	5	22.2	1.88	3	33.5	1.01	33	17.7	1.02	31	25.9	1.54	18	22.4	1.09
	m	14	90.9	3.79	9	25.5	1.37	8	36.4	2.44	14	20.4	1.00	14	30.1	1.58	12	23.3	0.90
<i>U. arctos</i>	f	17	75.5	5.59	17	16.0	1.56	12	22.2	2.19	17	11.6	1.18	17	18.3	1.46	11	15.7	1.21
	m	10	89.0	9.48	10	20.5	2.81	9	27.6	2.47	10	14.3	1.93	10	22.5	2.52	10	19.4	1.75

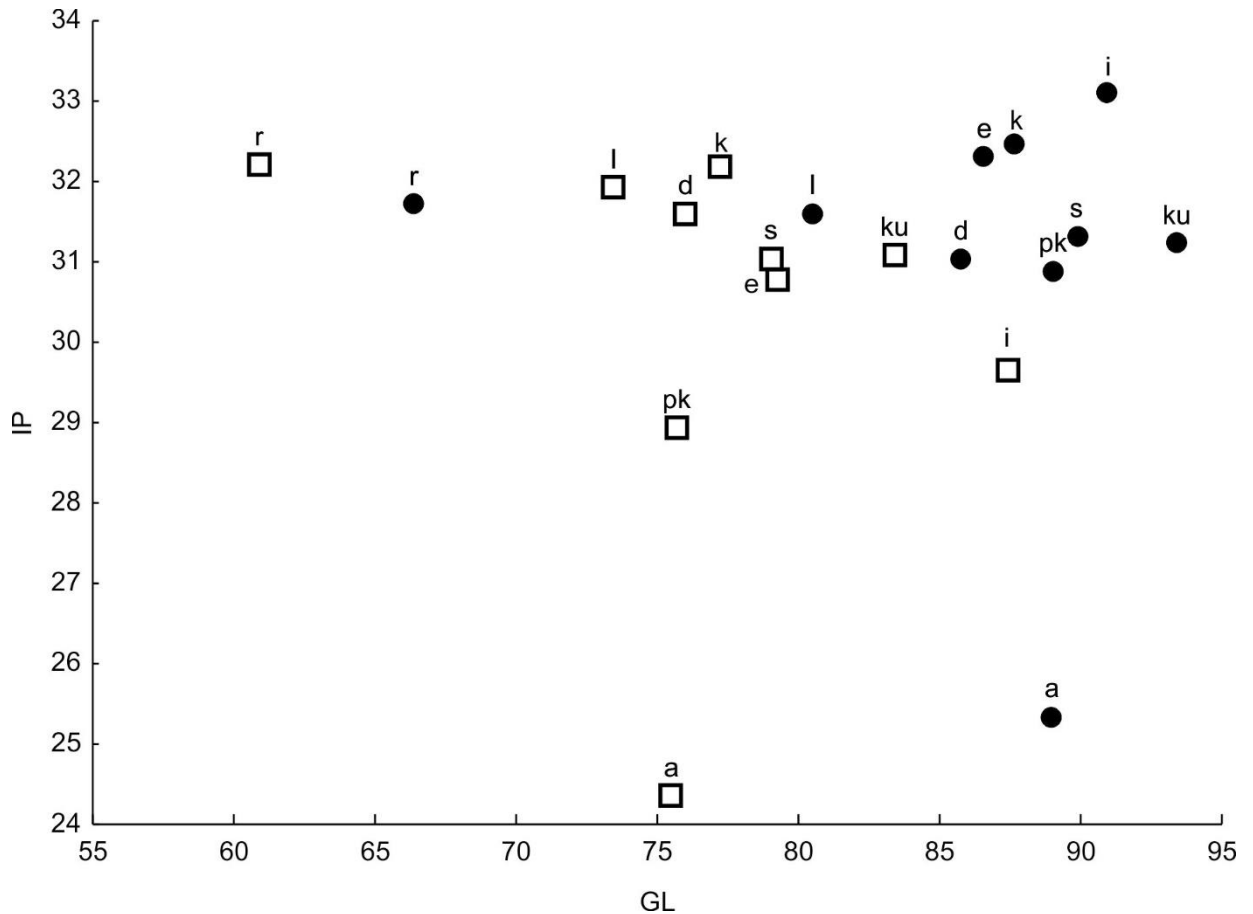

Fig. S17. The scatterplot of Index plumpness (ip) and GL of mtc IV: a – *U. arctos*, r – *U. rossicus*, d – *U. deningeri*, pk – *U. k. praekudarensis*, ku – *U. k. kudarensis*, s – *U. s. spelaeus*, k – *U. k. kanivetzi*, i – *U. k. ingressus*, e – *U. s. eremus*, l – *U. s. ladinicus*. Points – males, squares – females.

### Multivariate analysis

Table 26. Description of the modeled morphological spaces for cave bears and brown bear mtc IV. Correlation coefficients among the measures and dimensions of two morphospace models (MDS axes: E1–E2, K1–K2);  $r^2$  – coefficients of determination in the linear multiple regression models.

Measures	Morphospaces with <i>U. arctos</i>				$r^2$	Morphospaces without <i>U. arctos</i>				$r^2$
	“Size”		“Shape”			“Size”		“Shape”		
	morphospace		morphospace			morphospace		morphospace		
	E1	E2	K1	K2		E1	E2	K1	K2	
GL	0.88	0.44	-0.36	-0.17	0.97	0.94	-0.21	0.12	-0.40	0.96
Bp	0.96	-0.03	0.14	-0.06	0.93	0.95	0.01	-0.08	-0.02	0.93
Dp	0.95	0.06	0.02	0.07	0.94	0.94	-0.21	0.14	-0.10	0.93
SD	0.93	-0.27	0.26	-0.24	0.96	0.93	0.31	-0.35	-0.22	0.98
Bd	0.97	-0.13	0.17	-0.24	0.96	0.96	0.07	-0.12	-0.20	0.93
Dd	0.96	0.08	-0.05	-0.07	0.94	0.95	-0.15	0.07	-0.19	0.92
ip	0.18	-0.68	0.69	-0.18	0.84	0.19	0.54	-0.47	0.34	0.46
Relative variance (%) of dimensions associated with taxonomical composition										
	67.1	60.9	47.9	9.6		65.0	32.1	24.4	12.6	

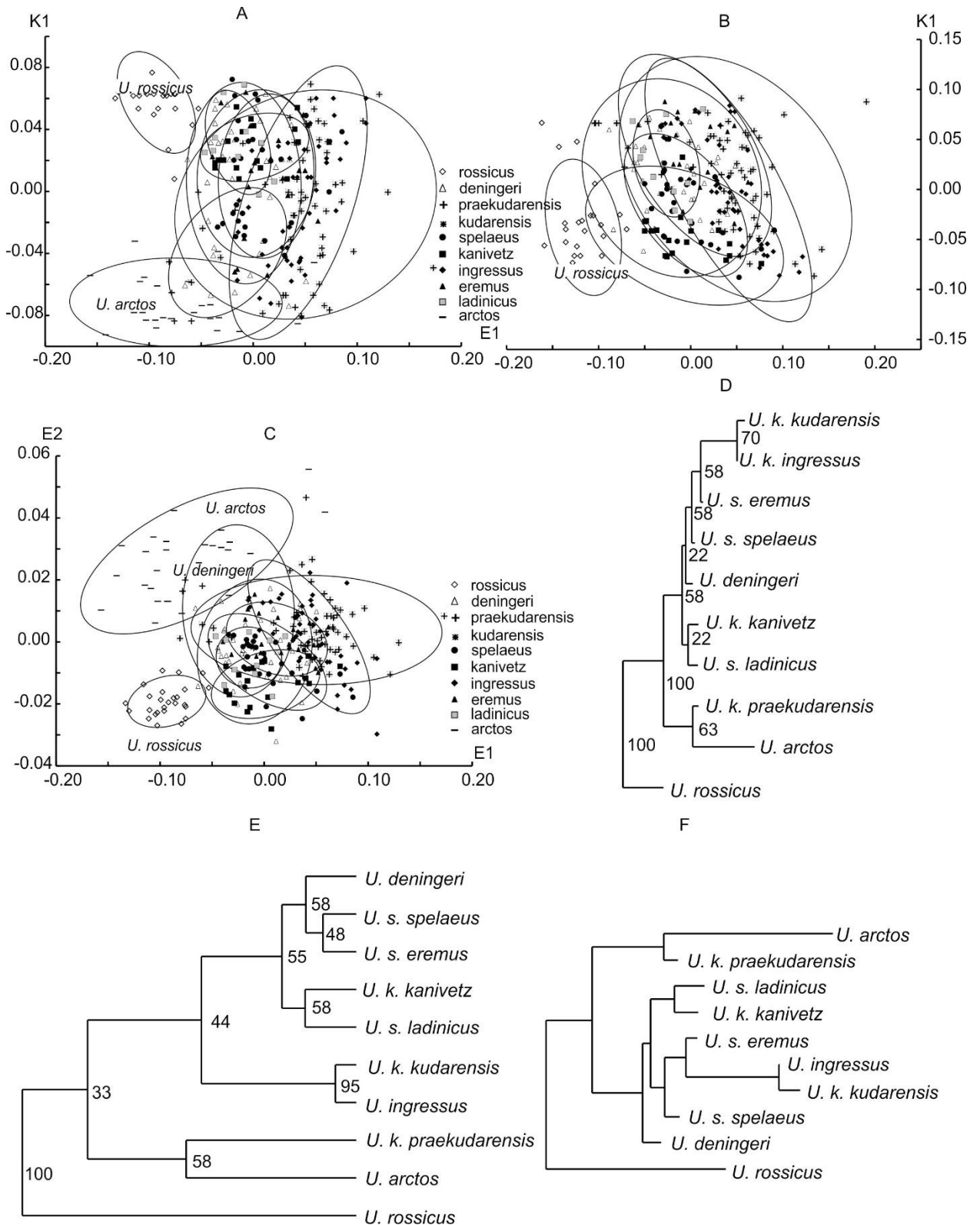

Fig. S18. Scatterplot of the first dimensions of "size" (E1) and "shape" (K1) morphospaces reproduced variation of mtc IV in males and females: A, C – models with *U. arctos*; B – model without *U. arctos*; C – "size" morphospace; D – NJ tree; E – UGMA dendrogram (cophenetic correlation – 0.86); F – Sattath-Tversky (Sattath, Tversky, 1977) additive tree. All classifications based on the coordinates of samples' centroids in the "size" (E1, E2) and "shape" (K1, K2) morphospaces (numbers near the nodes - bootstrap (1000 repeats) supports in %). Ellipses' horizontal and vertical projection onto the E1 (E2) and K1 axes are equal to the "sample mean" (centroid)  $\pm$  "sample range"  $\times$  0.95.

**Males**

Table S27. Description of the modeled morphological spaces for males of cave bears and brown bear mtc IV. Correlation coefficients among the measures and dimensions of two morphospace models (MDS axes: E1–E2, K1–K2);  $r^2$  – coefficients of determination in the linear multiple regression models.

Measures	Morphospaces with <i>U. arctos</i>				$r^2$	Morphospaces without <i>U. arctos</i>		
	“Size”		“Shape”			“Size”		“Shape”
	morphospace		morphospace			morphospace		morphospace
	E1	E2	K1	K2		E1	K1	$r^2$
GL	0.83	0.40	-0.35	-0.05	0.94	0.91	0.31	0.89
Bp	0.93	-0.14	0.23	0.15	0.94	0.92	-0.13	0.89
Dp	0.95	-0.09	0.04	-0.04	0.90	0.94	0.13	0.87
SD	0.90	-0.47	0.33	-0.12	0.92	0.89	-0.25	0.87
Bd	0.96	-0.24	0.22	-0.21	0.97	0.96	0.05	0.93
Dd	0.95	0.04	-0.07	-0.05	0.92	0.92	0.28	0.89
ip	0.23	-0.60	0.62	-0.17	0.81	0.25	-0.40	0.24
Relative variance (%) of dimensions associated with taxonomical composition								
	80.6	65.3	42.4	0.0		83.9	34.3	

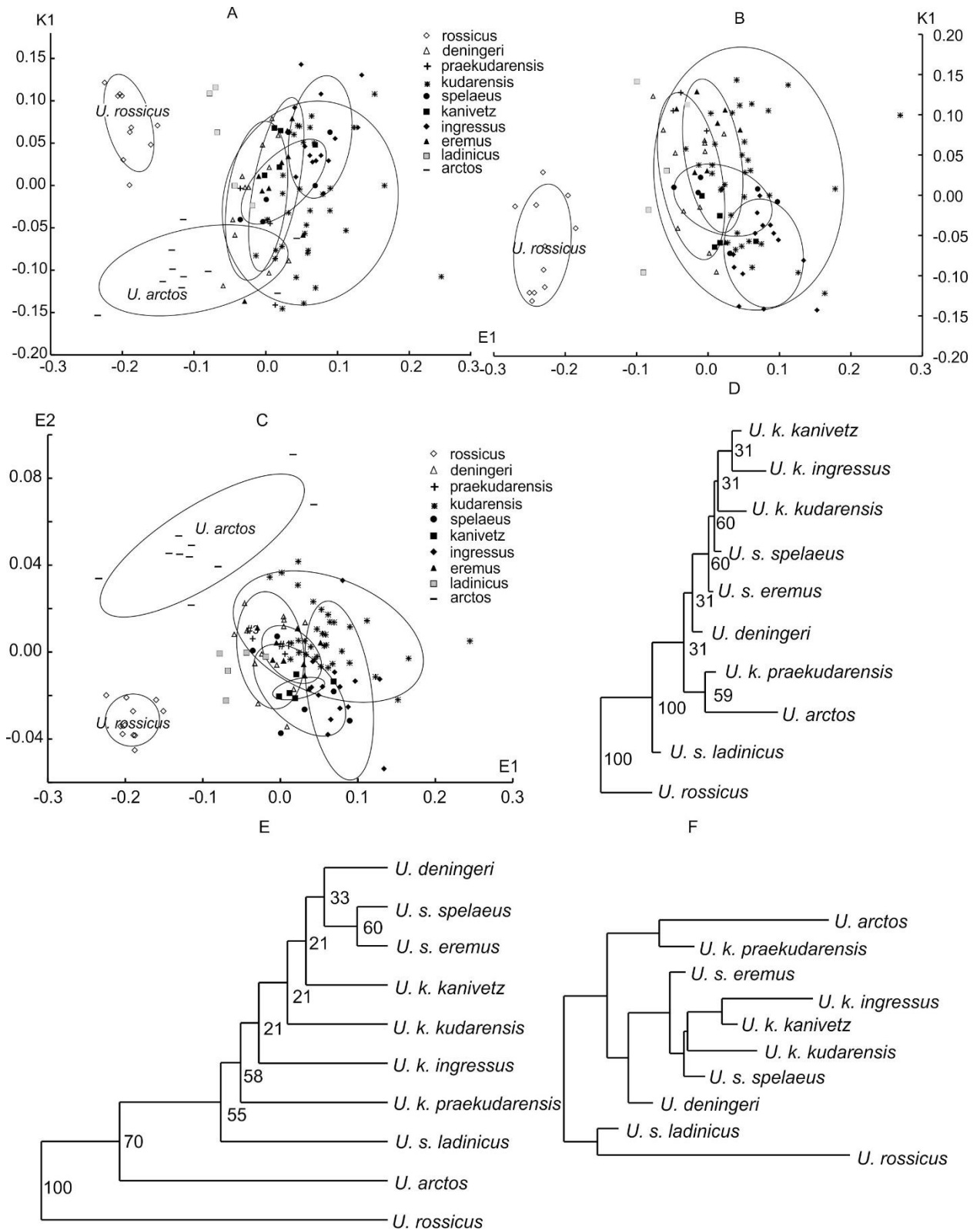

Fig. S19. Scatterplot of the first dimensions of “size” (E1) and “shape” (K1) morphospaces reproduced variation of mtc IV in males: A, C – models with *U. arctos*; B – model without *U. arctos*; C – “size” morphospace; D – NJ tree; E – UGMA dendrogram (cophenetic correlation – 0.93); F – Sattath-Tversky (Sattath, Tversky, 1977) additive tree. All classifications based on the coordinates of samples’ centroids in the “size” (E1, E2) and “shape” (K1, K2) morphospaces (numbers near the nodes - bootstrap (1000 repeats) supports in %). Ellipses’ horizontal and vertical projection onto the E1 (E2) and K1 axes are equal to the “sample mean” (centroid) ± “sample range” x 0.95.

## Females

Table S28. Description of the modeled morphological spaces for females of cave bears and brown bear mtc IV. Correlation coefficients among the measures and dimensions of two morphospace models (MDS axes: E1–E2, K1–K2);  $r^2$  – coefficients of determination in the linear multiple regression models.

Measures	Morphospaces with <i>U. arctos</i>					Morphospaces without <i>U. arctos</i>				
	“Size”		“Shape”		$r^2$	“Size”		“Shape”		$r^2$
	morphospace		morphospace			morphospace		morphospace		
	E1	E2	K1	K2	E1	E2	K1	K2		
GL	0.77	0.40	-0.20	-0.10	0.89	0.92	-0.17	0.07	0.04	0.93
Bp	0.95	-0.18	0.26	-0.43	0.90	0.93	0.04	-0.13	0.19	0.85
Dp	0.95	-0.05	0.07	-0.33	0.91	0.93	-0.19	0.07	0.42	0.97
SD	0.93	-0.44	0.48	-0.35	0.95	0.91	0.37	-0.47	0.29	0.96
Bd	0.96	-0.33	0.37	-0.27	0.96	0.94	0.22	-0.29	0.28	0.91
Dd	0.96	-0.10	0.10	-0.48	0.96	0.94	-0.04	-0.10	0.05	0.92
ip	-0.05	-0.67	0.61	0.18	0.77	-0.04	0.57	-0.56	0.45	0.57
Relative variance (%) of dimensions associated with taxonomical composition										
	81.2	66.6	48.1	28.9		75.1	35.6	25.6	7.1	



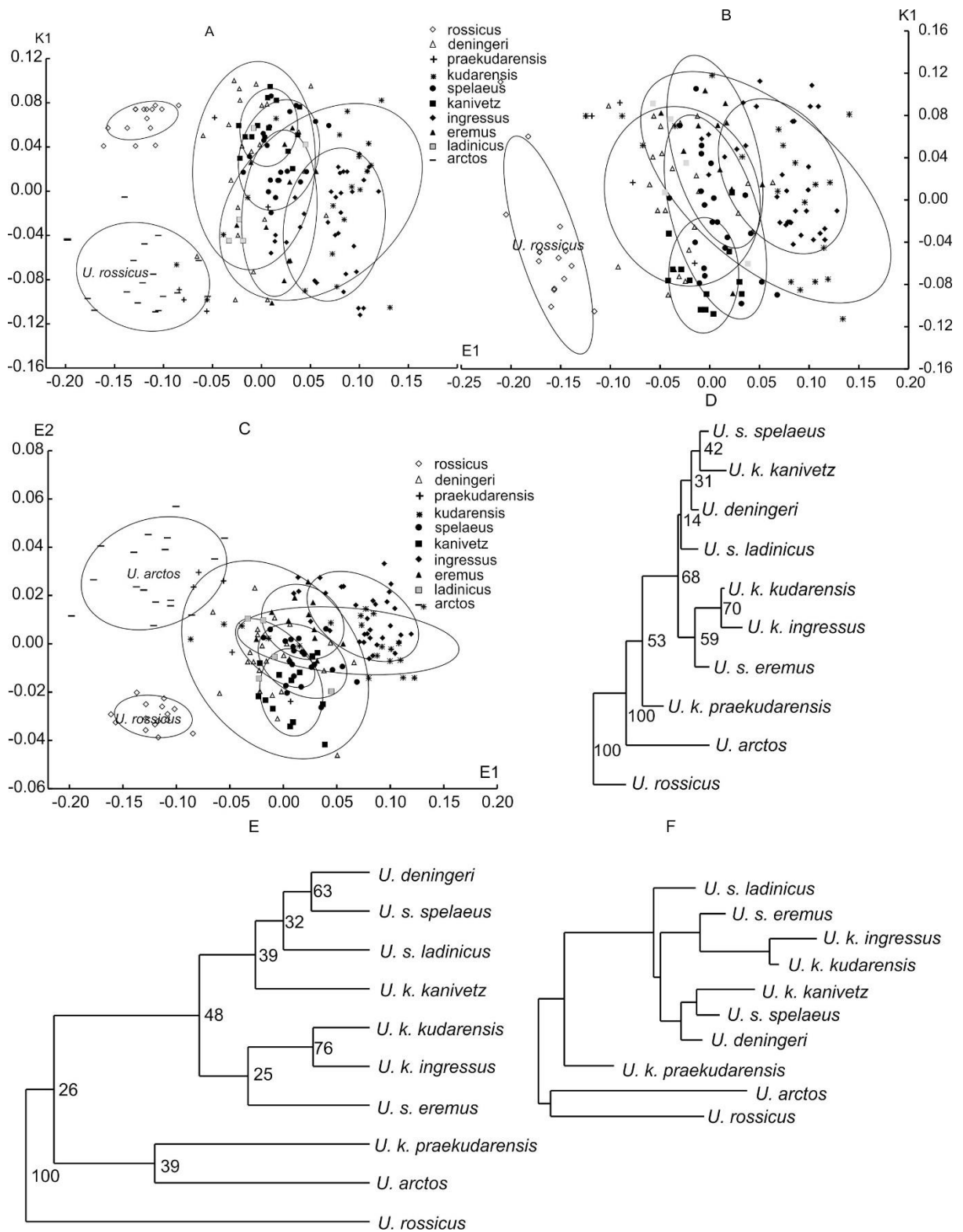

Fig. S20. Scatterplot of the first dimensions of “size” (E1) and “shape” (K1) morphospaces reproduced variation of mtc IV in females: A, C – models with *U. arctos*; B – model without *U. arctos*; C – “size” morphospace; D – NJ tree; E – UGMA dendrogram (cophenetic correlation – 0.81); F – Sattath-Tversky (Sattath, Tversky, 1977) additive tree. All classifications based on the coordinates of samples’ centroids in the “size” (E1, E2) and “shape” (K1, K2) morphospaces (numbers near the nodes - bootstrap (1000 repeats) supports in %). Ellipses’ horizontal and vertical projection onto the E1 (E2) and K1 axes are equal to the “sample mean” (centroid) ± “sample range” x 0.95.

**METACARPAL BONE V (MTC V)****Males and females**

Table S29. Sample numbers (N), means (M), and standard errors (m) of the variables of mtc V among different forms of bears

Form	GL		Bp		Dp		SD	
	N	M±m	N	M±m	N	M±m	N	M±m
<i>U. etruscus</i> *	3	79.3±2.89	1	19.5	no data		3	13.8±0.59
<i>U. deningeri</i>	40	79.4±1.00	38	26.6±0.46	39	31.8±0.56	40	16.7±0.26
<i>U. k. praekudarensis</i>	4	86.7±4.32	6	29.7±1.66	8	36.3±1.62	9	17.5±0.87
<i>U. k. kudarensis</i>	63	89.9±0.70	71	32.0±0.32	74	36.8±0.41	74	19.2±0.24
<i>U. rossicus</i>	15	62.0±0.88	18	21.9±0.31	17	27.0±0.60	17	14.3±0.25
<i>U. s. spelaeus</i>	11	86.5±1.90	9	30.1±0.91	11	34.6±1.12	10	19.3±0.69
<i>U. k. kanivetz</i>	22	82.6±1.25	21	29.5±0.46	22	34.5±0.94	22	18.3±0.37
<i>U. s. eremus</i>	20	80.6±1.08	20	28.2±0.48	20	33.3±0.71	20	16.7±0.33
<i>U. s. ladinicus</i>	6	77.5±1.58	6	27.1±0.54	6	32.7±1.10	6	16.4±0.25
<i>U. k. ingressus</i>	55	88.6±0.71	27	31.3±0.55	27	36.8±0.68	57	19.7±0.28
<i>U. arctos</i>	31	83.9±1.85	29	23.3±0.70	23	28.2±1.04	31	14.3±0.48
			Bd		Dd			
			N	M±m	N	M±m		
<i>U. etruscus</i> *			3	20.6±1.20	3	16.5±0.65		
<i>U. deningeri</i>			40	26.5±0.35	40	19.5±0.28		
<i>U. k. praekudarensis</i>			5	28.7±1.46	5	21.5±0.97		
<i>U. k. kudarensis</i>			63	30.2±0.36	59	22.8±0.19		
<i>U. rossicus</i>			15	22.6±0.55	12	15.6±0.25		
<i>U. s. spelaeus</i>			10	28.9±0.84	6	21.4±0.72		
<i>U. k. kanivetz</i>			22	28.5±0.70	20	20.7±0.39		
<i>U. s. eremus</i>			20	26.3±0.38	19	20.3±0.25		
<i>U. s. ladinicus</i>			6	26.2±0.63	6	19.5±0.31		
<i>U. k. ingressus</i>			54	30.1±0.37	38	22.8±0.25		
<i>U. arctos</i>			31	22.4±0.56	23	18.4±0.54		

\* Males only

**Sexual size dimorphism**Table S30. Sexual size dimorphism (SSD and ASSD) of mtc V in the different forms of cave bears and brown bear; *p* based on Mann-Whitney U Test; *v*, % - relative variance associated with SSD.

	SSD						ASSD
	GL	Bp	Dp	SD	Bd	Dd	
	<i>U. deningeri</i>						
Males	84.1±1.11	28.9±0.47	34.5±0.49	17.9±0.29	28.1±0.38	20.7±0.35	
Females	75.0±0.86	24.6±0.35	29.3±0.56	15.6±0.23	24.9±0.33	18.5±0.26	
SSD	5.7±0.88	8.0±1.10	8.2±1.17	6.9±1.11	6.0±0.95	5.6±1.11	6.7
<i>v</i> , %	( <i>p</i> <0.001)	( <i>p</i> <0.001)	( <i>p</i> <0.001)	( <i>p</i> <0.001)	( <i>p</i> <0.001)	( <i>p</i> <0.001)	
	70.8	74.8	69.7	64.8	64.9	53.9	
	<i>U. rossicus</i>						
Males	63.9±1.13	22.8±0.48	28.9±1.05	14.8±0.5	23.6±0.87	16.1±0.30	
Females	59.7±0.77	21.3±0.26	25.7±0.33	13.9±0.07	21.4±0.32	15.3±0.33	
SSD	3.4±1.11	3.4±1.24	5.9±2.02	n.s.	4.9±2.06	n.s.	3.9

	SSD						ASSD
	GL	Bp	Dp	SD	Bd	Dd	
<i>v</i> , %	( <i>p</i> =0.01) 40.2	( <i>p</i> =0.03) 26.1	( <i>p</i> =0.003) 56.7	-	( <i>p</i> =0.01) 56.5	-	
<i>U. k. praekudarensis</i>							
Males	90.3±3.35	32.1±0.9	38.6±0.75	18.5±0.7	29.7±1.39	22.1±0.96	
Females	75.8*	24.8±0.25	29.4±1.05	13.9±0.75	24.8*	19.0*	
SSD	8.7	12.8±1.7 ( <i>p</i> =0.056)	13.5±1.91 ( <i>p</i> =0.056)	14.2±3.2 ( <i>p</i> =0.056)	9.0	7.5	10.9
<i>v</i> , %*	-	-	-	-	-	-	
<i>U. k. kudarensis</i>							
Males	91.4±0.44	32.8±0.24	38.1±0.31	19.9±0.22	31.2±0.28	23.3±0.15	
Females	81.2±1.34	29.4±1.93	32.6±0.84	17.1±0.5	26.3±0.65	20.9±0.41	
SSD	5.9±0.82 ( <i>p</i> <0.001)	5.5±1.55 ( <i>p</i> <0.001)	7.8±1.27 ( <i>p</i> <0.001)	7.6±1.48 ( <i>p</i> <0.001)	8.5±1.24 ( <i>p</i> <0.001)	5.4±0.99 ( <i>p</i> <0.001)	6.8
<i>v</i> , %	80.6	51.0	62.1	50.7	67.9	66.5	
<i>U. s. spelaeus</i>							
Males	91.6±0.67	31.8±0.92	37.2±1.14	21.2±0.35	30.8±0.44	23.4±0.45	
Females	80.4±1.46	28.1±0.96	31.5±0.71	17.3±0.40	26.2±0.84	20.4±0.54	
SSD	6.5±0.93 ( <i>p</i> =0.008)	6.2±2.22 ( <i>p</i> =0.04)	8.3±1.96 ( <i>p</i> =0.01)	10.1±1.39 ( <i>p</i> =0.01)	8.1±1.67 ( <i>p</i> =0.01)	n.s.	7.7
<i>v</i> , %	83.9	78.9	89.7	92.6	88.3	-	
<i>U. s. ladinicus</i>							
Males	80.5±1.63	27.7±0.58	34.8±0.73	16.6±0.24	27.1±0.32	19.7±0.55	
Females	74.6±1.16	26.5±0.87	30.6±1.03	16.1±0.43	25.3±1.02	19.4±0.37	
SSD	n.s.	n.s.	n.s.	n.s.	n.s.	n.s.	3.0
<i>v</i> , %*	-	-	-	-	-	-	
<i>U. s. eremus</i>							
Males	87.2±1.60	31.0±0.69	37.4±0.64	18.6±0.25	28.8±0.33	23.9±2.10	
Females	78.4±0.69	27.2±0.33	31.9±0.59	16.1±0.27	25.5±0.21	19.9±0.21	
SSD	5.3±1.05 ( <i>p</i> =0.002)	6.6±1.32 ( <i>p</i> =0.001)	7.8±1.25 ( <i>p</i> =0.001)	7.2±1.07 ( <i>p</i> =0.002)	6.2±0.73 ( <i>p</i> =0.001)	9.1±4.84 ( <i>p</i> =0.008)	7.0
<i>v</i> , %	79.5	79.8	72.9	76.3	89.3	73.9	
<i>U. k. ingressus</i>							
Males	91.9±0.58	33.4±0.30	39.4±0.47	21±0.22	31.7±0.25	23.5±0.13	
Females	83.0±0.33	28.4±0.47	33.1±0.37	17.4±0.24	27.0±0.35	20.5±0.37	
SSD	5.1±0.45 ( <i>p</i> <0.001)	8.1±0.91 ( <i>p</i> <0.001)	8.7±0.83 ( <i>p</i> <0.001)	9.4±0.85 ( <i>p</i> <0.001)	8.0±0.74 ( <i>p</i> <0.001)	6.8±0.89 ( <i>p</i> <0.001)	7.7
<i>v</i> , %	86.2	85.9	87.3	84.7	84.0	88.8	
<i>U. kanivetz</i>							
Males	88.7±1.1	32.5±0.44	39.2±0.98	20.2±0.27	31.8±0.59	22.6±0.41	
Females	79.2±1.03	27.7±0.55	31.9±0.69	17.3±0.31	26.6±0.60	19.7±0.27	
SSD	5.7±0.90 ( <i>p</i> <0.001)	8.0±1.17 ( <i>p</i> <0.001)	10.3±1.69 ( <i>p</i> <0.001)	7.8±1.11 ( <i>p</i> <0.001)	9.0±1.44 ( <i>p</i> <0.001)	6.9±1.16 ( <i>p</i> <0.001)	7.9
<i>v</i> , %	77.5	79.2	79.2	79.8	77.8	80.2	
<i>U. arctos</i>							
Males	91.1±2.0	26.4±0.69	31.3±0.95	15.9±0.38	24.7±0.60	19.8±0.46	
Females	76.2±1.52	20.5±0.53	23.3±0.71	12.1±0.27	19.9±0.41	16.3±0.78	
SSD	8.9±1.51 ( <i>p</i> <0.001)	12.6±1.87 ( <i>p</i> <0.001)	14.7±2.20 ( <i>p</i> <0.001)	13.4±1.67 ( <i>p</i> <0.001)	10.6±1.63 ( <i>p</i> <0.001)	9.7±2.52 ( <i>p</i> =0.002)	11.6
<i>v</i> , %	66.2	78.8	81.2	75.4	75.7	59.9	

Univariate analysis

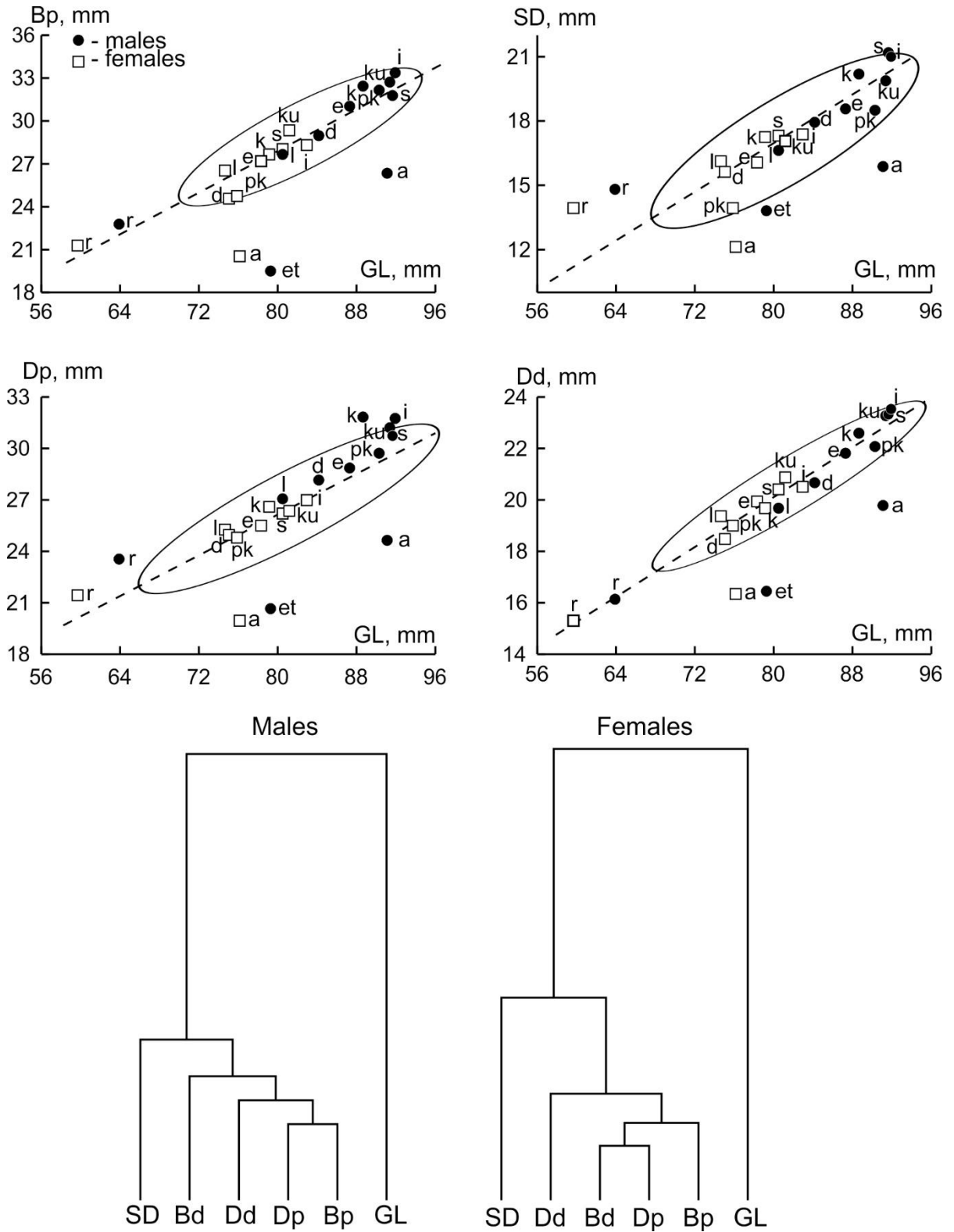

Fig. S21. The scatterplots of measures (GL – Dd) of mtc V and their classification: et – *U. etruscus*, a – *U. arctos*, r – *U. rossicus*, d – *U. deningeri*, pk – *U. k. praekudarensis*, ku – *U. k. kudarensis*, s – *U. s. spelaeus*, k – *U. k. kanivetz*, i – *U. k. ingressus*, e – *U. s. eremus*, l – *U. s. ladinicus*.

Table S31. Statistical parameters of measures of mtc V among different bears and sexes: m – males, f – females.

Taxa	Sex	GL - N	GL	Std.Dev.	BP - N	BP	Std.Dev.	Dp- N	Dp	Std.Dev.	SD - N	SD	Std.Dev.	Bd - N	Bd	Std.Dev.	Dd- N	Dd	Std.Dev.
<i>U. etruscus</i>	m	3	79.3	5.01	1	19.5					3	13.8	1.01	3	20.6	2.07	3	16.5	1.12
<i>U. rossicus</i>	m	8	63.9	3.21	8	22.8	1.37	7	28.9	2.79	8	14.8	1.43	8	22.9	0.91	5	16.1	0.66
	f	7	59.7	2.04	10	21.3	0.81	10	25.7	1.03	9	13.9	0.21	7	21.4	0.86	7	15.3	0.88
<i>U. deningeri</i>	m	19	84.1	4.85	18	28.9	1.99	19	34.5	2.14	19	17.9	1.25	19	28.1	1.64	19	20.7	1.55
	f	21	75	3.93	20	24.6	1.56	20	29.3	2.52	21	15.6	1.05	21	24.9	1.5	21	18.5	1.18
<i>U. k. praekudar.</i>	m	3	90.3	5.81	4	32.1	1.8	6	38.6	1.83	7	18.5	1.86	4	29.7	2.78	4	22.1	1.93
	f	1	75.8		2	24.8	0.35	2	29.4	1.48	2	13.9	1.06	1	24.8		1	19	
<i>U. k. kudarensis</i>	m	49	91.4	3.05	56	32.8	1.81	57	38.1	2.33	57	19.9	1.64	50	31.2	1.96	47	23.3	1.06
	f	14	81.2	5.02	15	29.4	3.61	17	32.6	3.47	17	17.1	2.04	13	26.3	2.35	12	20.9	1.43
<i>U. s. spelaeus</i>	m	6	91.6	1.63	5	31.8	2.07	6	37.2	2.79	5	21.2	0.78	6	30.8	1.09	2	23.4	0.64
	f	5	80.4	3.25	4	28.1	1.93	5	31.5	1.59	5	17.3	0.89	4	26.2	1.69	4	20.4	1.07
<i>U. k. kanivetz</i>	m	8	88.7	3.11	8	32.5	1.25	8	39.2	2.77	8	20.2	0.77	8	31.8	1.67	7	22.6	1.09
	f	14	79.2	3.86	13	27.7	1.97	14	31.9	2.57	14	17.3	1.16	14	26.6	2.24	13	19.7	0.98
<i>U. s. eremus</i>	m	5	87.2	3.57	5	31	1.54	5	37.4	1.42	5	18.6	0.55	5	28.8	0.74	4	21.8	0.43
	f	15	78.4	2.67	15	27.2	1.29	15	32	2.27	15	16.1	1.06	15	25.5	0.82	15	19.9	0.82
<i>U. s. ladinicus</i>	m	3	80.5	2.82	3	27.7	1.0	3	34.8	1.27	3	16.6	0.42	3	27.1	0.56	3	19.7	0.95
	f	3	74.6	2	3	26.5	1.51	3	30.6	1.78	3	16.1	0.75	3	25.3	1.77	3	19.4	0.64
<i>U. k. kanivetz</i>	m	35	91.9	3.43	16	33.4	1.22	16	39.4	1.87	36	21	1.29	35	31.7	1.49	29	23.5	0.69
	f	20	83	2.36	11	28.4	1.55	11	33.1	1.24	21	17.4	1.1	19	27	1.52	9	20.5	1.12
<i>U. arctos</i>	m	16	91.1	8	14	26.4	2.58	14	31.3	3.56	16	15.9	1.51	16	24.7	2.4	14	19.8	1.71
	f	15	76.2	5.89	15	20.5	2.06	9	23.3	2.12	15	12.1	1.04	15	19.9	1.58	9	16.3	2.34

Table S32. Kruskal-Wallis test  $z'$  values (males - above diagonal and females – under diagonal) for GL and BP of mtc V between bear taxa. The statistical significance values, according to 2-tailed  $p$  values, have been underlined.

Taxa		1	2	3	4	5	6	7	8	9	10
GL											
<i>U. deningeri</i>	1		1.75	1.90	<u>4.65</u>	3.01	<u>4.79</u>	1.44	0.73	0.74	2.93
<i>U. rossicus</i>	2	2.35		2.84	<u>5.23</u>	<u>3.97</u>	<u>5.36</u>	2.69	1.94	0.41	<u>4.00</u>
<i>U. k. praekudarensis</i>	3	0.05	1.01		0.12	0.32	0.30	0.85	1.12	2.01	0.30
<i>U. k. kudarensis</i>	4	<u>3.32</u>	<u>4.69</u>	1.05		0.35	0.49	1.70	1.89	2.89	0.91
<i>U. s. spelaeus</i>	5	2.20	<u>3.62</u>	0.95	0.10		0.10	1.48	1.72	2.64	0.86
<i>U. k. ingressus</i>	6	<u>5.00</u>	<u>5.90</u>	1.47	1.20	0.94		1.94	2.09	3.03	1.23
<i>U. k. kanivetz</i>	7	2.26	<u>3.90</u>	0.70	0.97	0.61	2.25		0.42	1.58	0.90
<i>U. s. eremus</i>	8	1.78	<u>3.56</u>	0.53	1.46	0.95	2.82	0.48		1.13	1.22
<i>U. s. ladinicus</i>	9	0.41	1.12	0.26	2.19	1.84	2.93	1.62	1.35		2.31
<i>U. arctos</i>	10	0.68	2.74	0.17	2.47	1.68	<u>3.91</u>	1.48	1.02	0.76	
Bp											
<i>U. deningeri</i>	1		1.93	2.13	<u>4.69</u>	1.67	<u>4.67</u>	2.92	1.20	0.59	1.30
<i>U. rossicus</i>	2	1.99		3.26	<u>5.53</u>	2.92	<u>5.60</u>	<u>4.12</u>	2.50	0.67	0.80
<i>U. k. praekudarensis</i>	3	0.05	0.95		0.18	0.49	0.77	0.10	0.85	2.02	2.89
<i>U. k. kudarensis</i>	4	<u>3.81</u>	<u>5.08</u>	1.78		0.92	1.18	0.09	1.43	2.76	<u>5.81</u>
<i>U. s. spelaeus</i>	5	2.19	<u>3.33</u>	1.43	0.18		1.49	0.69	0.38	1.66	2.51
<i>U. k. ingressus</i>	6	<u>3.50</u>	<u>4.77</u>	1.76	0.03	0.19		0.85	1.95	3.13	<u>5.65</u>
<i>U. k. kanivetz</i>	7	2.98	<u>4.36</u>	1.45	0.63	0.24	0.61		1.11	2.37	<u>3.84</u>
<i>U. s. eremus</i>	8	2.81	<u>4.24</u>	1.33	0.93	0.42	0.89	0.27		1.33	2.05
<i>U. s. ladinicus</i>	9	1.05	2.16	0.75	1.03	0.72	1.02	0.64	0.49		0.15
<i>U. arctos</i>	10	2.62	0.30	1.14	<u>6.01</u>	<u>3.72</u>	<u>5.56</u>	<u>5.16</u>	<u>5.08</u>	2.44	
Dp											
<i>U. deningeri</i>	1		1.61	2.87	<u>4.29</u>	2.01	<u>4.74</u>	<u>3.58</u>	1.81	0.03	1.24
<i>U. rossicus</i>	2	2.22		<u>3.69</u>	<u>4.61</u>	2.97	<u>5.12</u>	<u>4.29</u>	2.76	1.00	0.59
<i>U. k. praekudarensis</i>	3	0.00	1.10		0.48	0.70	<u>0.56</u>	0.31	0.72	1.92	<u>3.65</u>
<i>U. k. kudarensis</i>	4	2.87	<u>4.53</u>	1.27		0.46	1.67	0.99	0.49	1.95	<u>5.28</u>
<i>U. s. spelaeus</i>	5	1.39	2.84	0.83	0.49		1.40	1.05	0.06	1.36	2.83
<i>U. k. ingressus</i>	6	<u>3.41</u>	<u>4.89</u>	1.67	0.86	1.08		0.23	1.37	2.59	<u>5.60</u>
<i>U. k. kanivetz</i>	7	2.23	<u>3.95</u>	1.03	0.47	0.16	1.25		1.06	2.26	<u>4.39</u>
<i>U. s. eremus</i>	8	2.60	<u>4.27</u>	1.18	0.17	0.37	0.99	0.30		1.27	2.58
<i>U. s. ladinicus</i>	9	0.52	1.79	0.35	1.00	0.51	1.47	0.72	0.90		0.66
<i>U. arctos</i>	10	2.75	0.54	1.41	<u>4.97</u>	3.23	<u>5.30</u>	<u>4.40</u>	<u>4.72</u>	2.14	
SD											
<i>U. deningeri</i>	1		1.94	0.77	<u>3.58</u>	<u>3.40</u>	<u>5.43</u>	2.67	0.37	0.79	1.78
<i>U. rossicus</i>	2	2.05		2.24	<u>4.69</u>	<u>4.43</u>	<u>6.04</u>	<u>3.89</u>	1.76	0.48	0.50
<i>U. k. praekudarensis</i>	3	1.14	0.04		1.52	2.34	2.91	1.52	0.26	1.21	2.08
<i>U. k. kudarensis</i>	4	2.40	<u>3.88</u>	2.18		1.63	2.78	0.46	1.64	2.43	<u>5.49</u>
<i>U. s. spelaeus</i>	5	2.13	<u>3.36</u>	2.28	0.54		0.35	1.03	2.41	3.01	<u>4.51</u>
<i>U. k. ingressus</i>	6	<u>3.38</u>	<u>4.66</u>	2.55	0.79	0.04		1.06	2.84	<u>3.38</u>	<u>7.13</u>
<i>U. k. kanivetz</i>	7	2.79	<u>4.16</u>	2.39	0.50	0.18	0.23		1.65	2.39	<u>3.99</u>
<i>U. s. eremus</i>	8	0.80	2.57	1.48	1.45	1.53	2.28	1.87		0.93	1.54
<i>U. s. ladinicus</i>	9	0.50	1.68	1.26	0.76	1.03	1.19	1.03	0.06		0.18
<i>U. arctos</i>	10	<u>3.67</u>	1.01	0.52	<u>5.71</u>	<u>4.46</u>	<u>6.75</u>	<u>5.93</u>	<u>4.14</u>	2.45	
Bd											
<i>U. deningeri</i>	1		1.71	1.18	<u>4.36</u>	1.90	<u>4.92</u>	<u>3.27</u>	0.20	0.39	1.74
<i>U. rossicus</i>	2	2.63		2.24	<u>4.97</u>	2.98	<u>5.42</u>	<u>4.20</u>	1.44	0.70	0.30
<i>U. k. praekudarensis</i>	3	0.30	0.78		1.01	0.37	1.43	1.19	0.82	1.17	2.22

Taxa		1	2	3	4	5	6	7	8	9	10
<i>U. k. kudarensis</i>	4	1.35	<u>3.46</u>	0.76		0.65	1.04	0.53	2.29	2.39	<u>6.14</u>
<i>U. s. spelaeus</i>	5	0.89	2.61	0.71	0.02		1.16	0.90	1.31	1.61	3.09
<i>U. k. ingressus</i>	6	2.78	<u>4.59</u>	1.16	1.12	0.72		0.07	2.73	2.74	<u>6.61</u>
<i>U. k. kanivetz</i>	7	1.86	<u>3.86</u>	0.92	0.43	0.27	0.68		2.24	2.40	<u>4.54</u>
<i>U. s. eremus</i>	8	0.62	2.96	0.50	0.71	0.49	1.95	1.16		0.47	1.35
<i>U. s. ladinicus</i>	9	0.07	1.73	0.31	0.67	0.58	1.35	0.94	0.26		0.55
<i>U. arctos</i>	10	<u>4.02</u>	0.46	1.01	<u>4.84</u>	<u>3.28</u>	<u>6.48</u>	<u>5.38</u>	<u>4.29</u>	2.22	
Dd											
<i>U. deningeri</i>	1		1.67	1.20	<u>4.84</u>	1.91	<u>5.18</u>	2.05	0.47	0.58	0.73
<i>U. rossicus</i>	2	2.18		2.24	<u>4.58</u>	2.70	<u>4.89</u>	2.98	1.64	0.65	1.12
<i>U. k. praekudarensis</i>	3	0.12	1.01		1.26	0.88	1.63	0.39	0.57	1.34	1.62
<i>U. k. kudarensis</i>	4	<u>3.86</u>	<u>4.93</u>	1.22		0.15	0.91	1.01	2.03	2.82	<u>5.16</u>
<i>U. s. spelaeus</i>	5	2.39	<u>3.60</u>	1.05	0.16		0.15	0.64	1.34	1.95	2.22
<i>U. k. ingressus</i>	6	3.21	<u>4.42</u>	1.09	0.27	0.04		1.48	2.38	3.12	<u>5.49</u>
<i>U. k. kanivetz</i>	7	2.23	<u>3.71</u>	0.64	1.52	0.90	1.13		1.03	1.84	2.51
<i>U. s. eremus</i>	8	2.82	<u>4.16</u>	0.80	1.14	0.62	0.77	0.44		0.81	0.91
<i>U. s. ladinicus</i>	9	0.86	2.14	0.35	1.34	1.01	1.12	0.40	0.67		0.17
<i>U. arctos</i>	10	1.42	0.77	0.65	<u>4.45</u>	3.11	<u>3.91</u>	3.12	<u>3.60</u>	1.64	

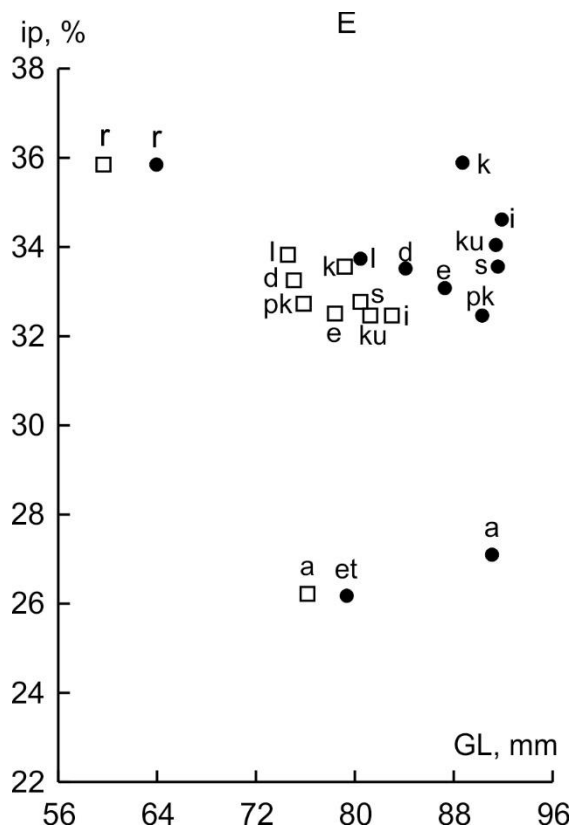

Fig. S22. Scatterplot of Index plumpness (ip) and GL of mtc V: et – *U. etruscus*, a – *U. arctos*, r – *U. rossicus*, d – *U. deningeri*, pk – *U. k. praekudarensis*, ku – *U. k. kudarensis*, s – *U. s. spelaeus*, k – *U. k. kanivetz*, k – *U. k. ingressus*, e – *U. s. eremus*, l – *U. s. ladinicus*. Points – males, squares – females.

**Multivariate analyses**

Table S33. Description of the modeled morphological spaces for cave bears and brown bear mtc V. Correlation coefficients among the measures and dimensions of two morphospace models (MDS axes: E1–E2, K1–K2);  $r^2$  – coefficients of determination in the linear multiple regression models.

Measures	Morphospaces with <i>U. arctos</i>					Morphospaces without <i>U. arctos</i>				
	“Size” morphospace		“Shape” morphospace		$r^2$	“Size” morphospace		“Shape” morphospace		$r^2$
	E1	E2	K1	K2		E1	E2	K1	K2	
GL	0.84	0.43	-0.08	-0.29	0.91	0.93	0.28	0.32	0.00	0.93
Bp	0.97	0.02	0.26	-0.01	0.94	0.96	0.10	0.18	0.00	0.93
Dp	0.96	-0.04	0.45	-0.11	0.96	0.95	0.01	0.14	0.31	0.95
SD	0.94	-0.20	0.38	0.25	0.96	0.93	-0.22	-0.16	-0.00	0.95
Bd	0.96	-0.19	0.44	0.02	0.96	0.95	-0.17	-0.03	0.18	0.95
Dd	0.96	0.13	0.19	-0.12	0.94	0.97	0.12	0.19	0.00	0.95
ip	0.48	-0.79	0.78	0.38	0.84	0.27	-0.74	-0.60	0.33	0.68
Relative variance (%) of dimensions associated with taxonomical composition										
	60.7	56.0	47.8	25.9		59.5	32.7	31.6	4.3	



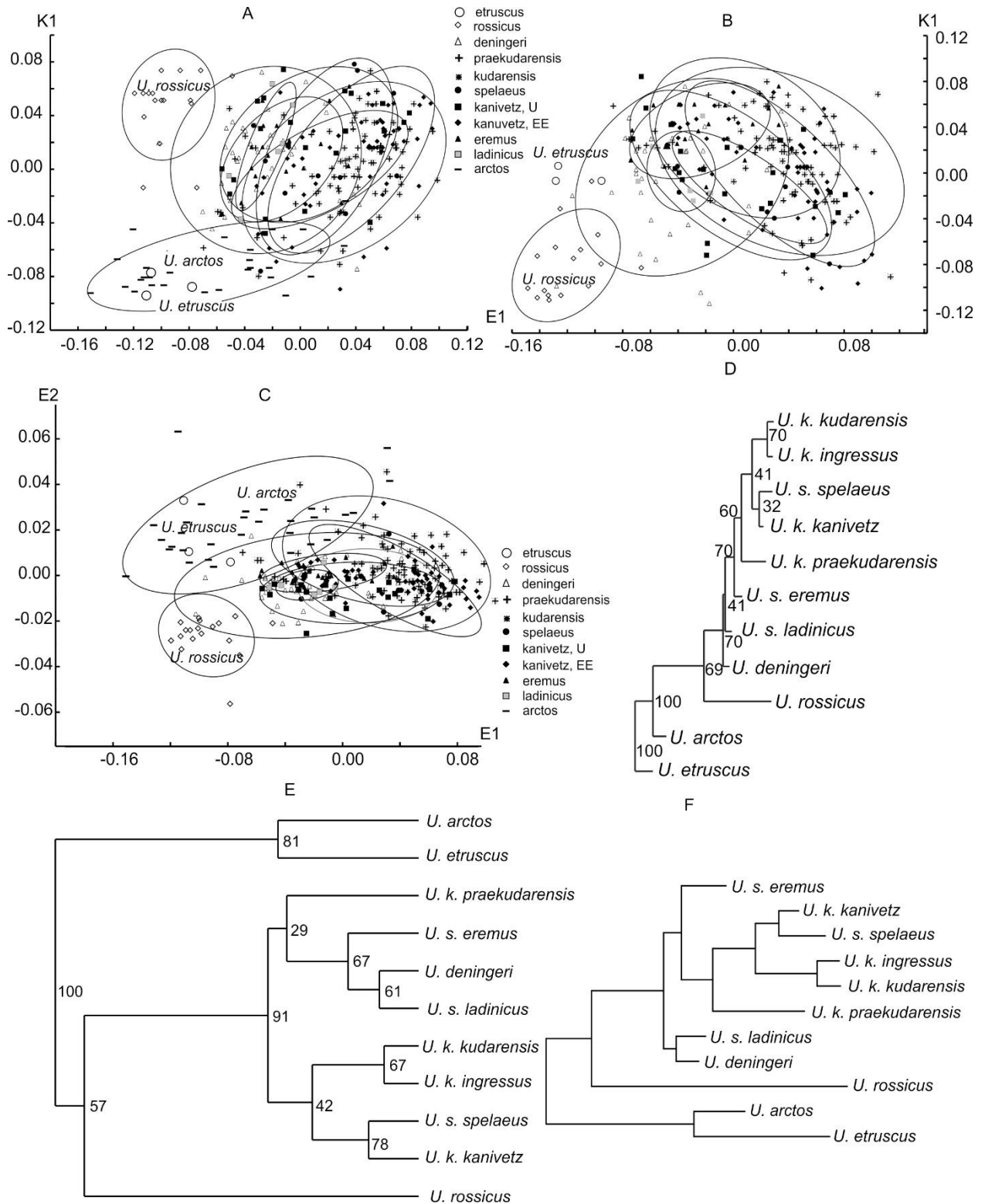

Fig. S23. Scatterplot of the first dimensions of “size” (E1) and “shape” (K1) morphospaces reproduced variation of mtc V in males and females: A, C – models with *U. arctos*; B – model without *U. arctos*; C – “size” morphospace; D – NJ tree; E – UGMA dendrogram (cophenetic correlation – 0.94); F – Sattath-Tversky (Sattath, Tversky, 1977) additive tree. All classifications based on the coordinates of samples’ centroids in the “size” (E1, E2) and “shape” (K1, K2) morphospaces (numbers near the nodes - bootstrap (1000 repeats) supports in %). Ellipses’ horizontal and vertical projection onto the E1 (E2) and K1 axes are equal to the “sample mean” ± (“sample range” x 0.95).

**Males**

Table S34. Description of the modeled morphological spaces for males of cave bears and brown bear mtc V. Correlation coefficients among the measures and dimensions of two morphospace models (MDS axes: E1–E2, K1–K2);  $r^2$  – coefficients of determination in the linear multiple regression models.

Measures	Morphospaces with <i>U. arctos</i>				$r^2$	Morphospaces without <i>U. arctos</i>			
	“Size”		“Shape”			“Size”		“Shape”	
	morphospace		morphospace			morphospace		morphospace	
	E1	E2	K1	K2		E1	K1	K2	$r^2$
GL	0.72	0.61	-0.33	0.09	0.87	0.92	0.39	0.43	0.86
Bp	0.96	0.07	0.25	0.15	0.92	0.95	0.12	0.35	0.91
Dp	0.93	0.04	0.33	-0.07	0.92	0.90	0.15	0.10	0.87
SD	0.91	-0.28	0.50	0.35	0.96	0.88	-0.24	0.35	0.92
Bd	0.96	-0.10	0.41	0.17	0.95	0.95	-0.05	0.30	0.94
Dd	0.96	0.21	0.10	0.22	0.96	0.96	0.20	0.50	0.95
ip	0.39	-0.59	0.71	0.07	0.81	0.36	-0.55	-0.21	0.58
Relative variance (%) of dimensions associated with taxonomical composition									
	81.7	55.5	53.9	17.8		84.8	21.3	28.7	

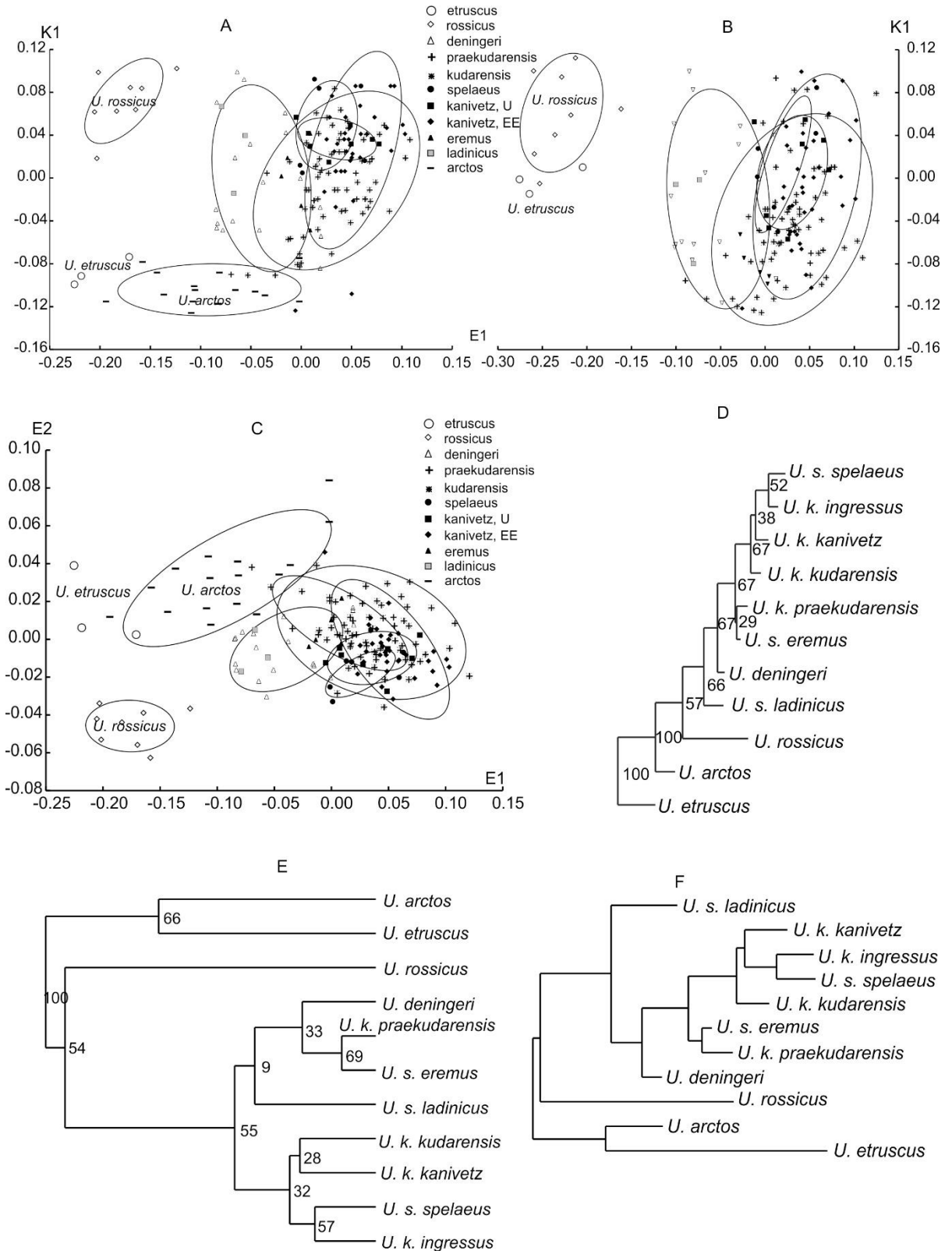

Fig. S24. Scatterplot of the first dimensions of "size" and "shape" morphospaces reproduced variation of mtc V in males: A, C – models with *U. arctos*; B – model without *U. arctos*; C – "size" morphospace; D – NJ tree; E – UGMA dendrogram (cophenetic correlation – 0.88); F – Sattath-Tversky (Sattath, Tversky, 1977) additive tree. All classifications based on the coordinates of samples' centroids in the "size" and "shape" morphospaces (numbers near the nodes - bootstrap (1000 repeats) supports in %). Ellipses' horizontal and vertical projections onto the axes are equal to the "sample mean" (centroid)  $\pm$  "highest value - "  $\times$  0.95.

## Females

Table S35. Description of the modeled morphological spaces for females of cave bears and brown bear mtc V. Correlation coefficients among the measures and dimensions of two morphospace models (MDS axes: E1–E2, K1–K2);  $r^2$  – coefficients of determination in the linear multiple regression models.

Measures	Morphospaces with <i>U. arctos</i>				$r^2$	Morphospaces without <i>U. arctos</i>				$r^2$
	“Size”		“Shape”			“Size”		“Shape”		
	morphospace		morphospace			morphospace		morphospace		
	E1	E2	K1	K2		E1	E2	K1	K2	
GL	0.76	0.58	-0.56	0.17	0.90	0.91	-0.27	0.23	-0.41	0.88
Bp	0.94	-0.04	-0.25	0.05	0.89	0.92	-0.07	0.22	-0.38	0.86
Dp	0.95	-0.07	-0.30	-0.04	0.89	0.92	-0.12	0.38	-0.11	0.89
SD	0.90	-0.30	0.04	0.02	0.95	0.87	0.33	-0.15	-0.20	0.95
Bd	0.91	-0.23	-0.12	-0.28	0.95	0.88	-0.16	0.19	0.00	0.86
Dd	0.96	0.07	-0.43	-0.08	0.95	0.94	-0.20	0.28	-0.30	0.89
ip	-0.10	-0.69	0.42	-0.64	0.88	-0.08	0.33	0.06	0.70	0.52
Relative variance (%) of dimensions associated with taxonomical composition										
	76.6	64.7	59.5	6.0		68.4	15.4	4.0	32.9	

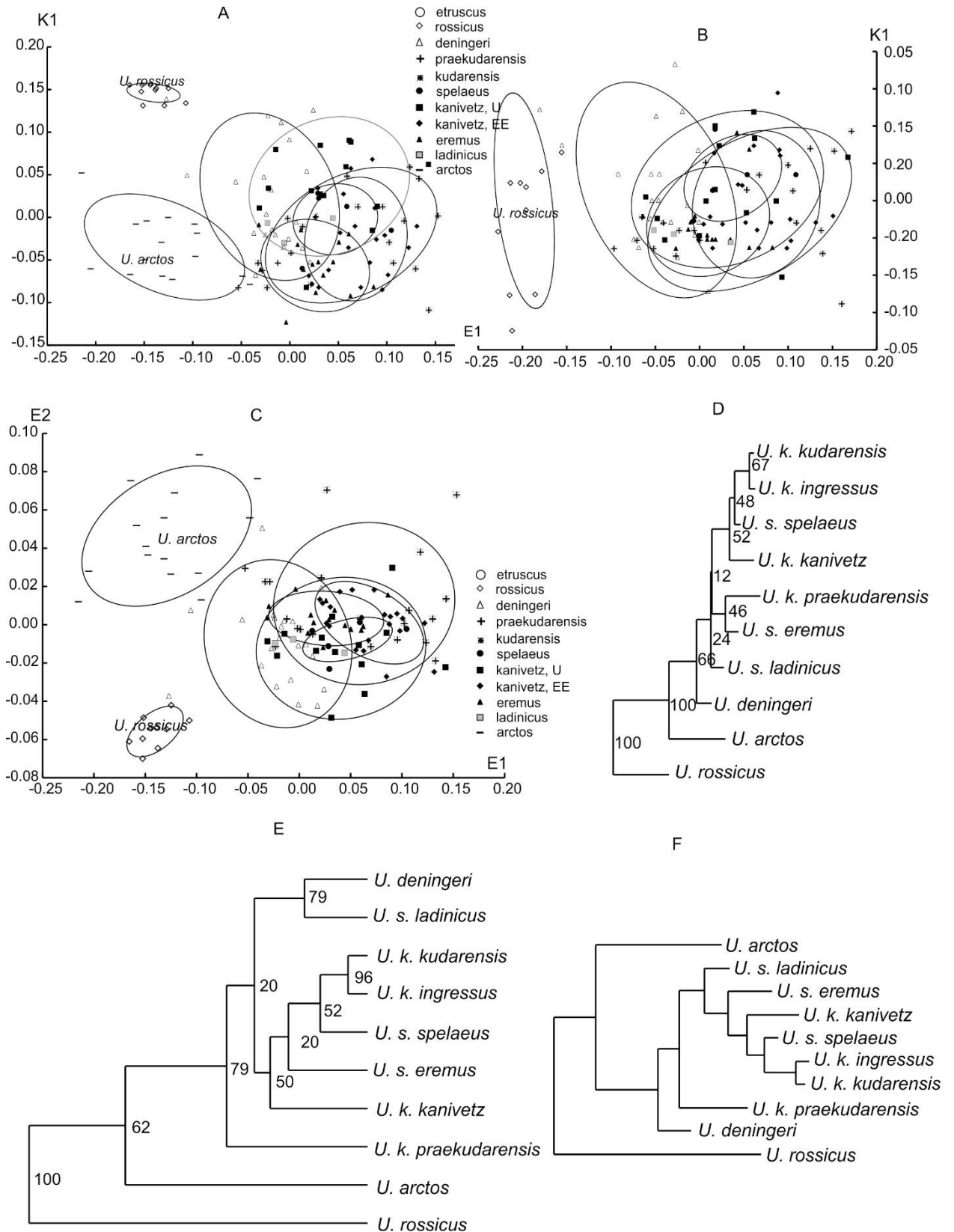

Fig. S25. Scatterplot of the first dimensions of “size” and “shape” morphospaces reproduced variation of mtc V in females: A, C – models with *U. arctos*; B – model without *U. arctos*; C – “size” morphospace; D – NJ tree; E – UGMA dendrogram (cophenetic correlation – 0.95); F – Sattath-Tversky (Sattath, Tversky, 1977) additive tree. All classifications based on the coordinates of samples’ centroids in the “size” and “shape” morphospaces (numbers near the nodes - bootstrap (1000 repeats) supports in %). Ellipses’ horizontal and vertical projections onto the axes are equal to the “sample mean” (centroid) ± “sample range” x 0.95.

## **Supplement II**

### **Additional materials to**

**Gennady F. Baryshnikov, Andrei Yu. Puzachenko**

### **Morphometrical analysis of metacarpal and metatarsal bones of cave bears (Carnivora, Ursidae)**

#### **Content**

METATARSAL BONE I (mtt I).....	8
Males and females.....	8
Sexual size dimorphism.....	8
Univariate analysis.....	10
Multivariate analyses.....	14
Males.....	16
Females.....	18
METATARSAL BONE II (mtt II).....	20
Males and females.....	20
Sexual dimorphism.....	20
Univariate statistic.....	22
Multivariate analysis.....	27
Males.....	29
Females.....	31
METATARSAL BONE III (mtt III).....	33
Males and females.....	33
Sexual dimorphism.....	33
Univariate analysis.....	35
Multivariate analysis.....	39
Males.....	41
Females.....	43
METATARSAL BONE IV (mtt IV).....	45
Males and females.....	45
Sexual dimorphism.....	45
Univariate analysis.....	47
Multivariate analysis.....	51
Males.....	53
Females.....	55
METATARSAL BONE V (mtt V).....	57
Males and females.....	57

Sexual size dimorphism.....	58
Univariate analysis.....	60
Multivariate analyses.....	64
Males.....	66
Females.....	68

## List of Figures

Fig. S1. The scatterplots of measures (GL – Dd) of mtt I and their UPMGA classification: et – <i>U. etruscus</i> , a – <i>U. arctos</i> , r – <i>U. rossicus</i> , d – <i>U. deningeri</i> , pk – <i>U. k. praekudarensis</i> , ku – <i>U. k. kudarensis</i> , s – <i>U. s. spelaeus</i> , k – <i>U. k. kanivetz</i> , i – <i>U. k. ingressus</i> , e – <i>U. s. eremus</i> , l – <i>U. s. ladinicus</i> .....	10
Fig. S2. The scatterplot of Index plumpness (ip) and GL of mtt I: et – <i>U. etruscus</i> , a – <i>U. arctos</i> , r – <i>U. rossicus</i> , sa – <i>U. savini</i> , d – <i>U. deningeri</i> , pk – <i>U. k. praekudarensis</i> , ku – <i>U. k. kudarensis</i> , s – <i>U. s. spelaeus</i> , k – <i>U. k. kanivetz</i> , i – <i>U. k. ingressus</i> , e – <i>U. s. eremus</i> , l – <i>U. s. ladinicus</i> . Point – males, square – females.....	12
Fig. S3. Scatterplot of the first dimensions of “size” (E1) and “shape” (K1) morphospaces reproduced variation of mtt I in males and females: A, C – models with <i>U. arctos</i> ; B – model without <i>U. arctos</i> ; C – “size” morphospace; D – NJ tree; E – UGMA dendrogram (cophenetic correlation – 0.89); F – Sattath-Tversky (Sattath, Tversky, 1977) additive tree. All classifications based on the coordinates of samples’ centroids in the “size” (E1, E2) and “shape” (K1, K2) morphospaces (numbers near the nodes - bootstrap (1000 repeats) supports in %). Ellipses’ horizontal and vertical projection onto the E1 (E2) and K1 axes are equal to the “sample mean” (centroid) $\pm$ “sample range” $\times$ 0.95.....	15
Fig. S4. Scatterplot of the first dimensions of “size” (E1) and “shape” (K1) morphospaces reproduced variation of mtt I in males: A, C – models with <i>U. arctos</i> ; B – model without <i>U. arctos</i> ; C – “size” morphospace; D – NJ tree; E – UGMA dendrogram (cophenetic correlation – 0.98); F – Sattath-Tversky (Sattath, Tversky, 1977) additive tree. All classifications based on the coordinates of samples’ centroids in the “size” (E1, E2) and “shape” (K1, K2) morphospaces (numbers near the nodes - bootstrap (1000 repeats) supports in %). Ellipses’ horizontal and vertical projection onto the E1 (E2) and K1 axes are equal to the “sample mean” (centroid) $\pm$ “sample range” $\times$ 0.95.....	17
Fig. S5. Scatterplot of the first dimensions of “size” (E1) and “shape” (K1) morphospaces reproduced variation of mtt I in females: A, C – models with <i>U. arctos</i> ; B – model without <i>U. arctos</i> ; C – “size” morphospace; D – NJ tree; E – UGMA dendrogram (cophenetic correlation – 0.90); F – Sattath-Tversky (Sattath, Tversky, 1977) additive tree. All classifications based on the coordinates of samples’ centroids in the “size” (E1, E2) and “shape” (K1, K2) morphospaces (numbers near the nodes - bootstrap (1000 repeats) supports in %). Ellipses’ horizontal and vertical projection onto the E1 (E2) and K1 axes are equal to the “sample mean” (centroid) $\pm$ “sample range” $\times$ 0.95.....	19
Fig. S6. The scatterplots of measures (GL – Dd) of mtt II and their UPMGA classification, and single linkage dendrograms of measurements based on the correlation metric. et – <i>U. etruscus</i> , a – <i>U. arctos</i> , r – <i>U. rossicus</i> , d – <i>U. deningeri</i> , pk – <i>U. k. praekudarensis</i> , ku – <i>U. k. kudarensis</i> , s – <i>U. s. spelaeus</i> , k, U – <i>U. k. kanivetz</i> , U, k, EE – <i>Ursus. kanivetz</i> , EE, e – <i>U. s. eremus</i> , l – <i>U. s. ladinicus</i> .....	24
Fig. S7. The scatterplot of Index plumpness (ip) and GL of mtt II: et – <i>U. etruscus</i> , a – <i>U. arctos</i> , r – <i>U. rossicus</i> , d – <i>U. deningeri</i> , pk – <i>U. k. praekudarensis</i> , ku – <i>U. k. kudarensis</i> , s – <i>U. s. spelaeus</i> , k – <i>U. k. kanivetz</i> , i – <i>U. k. ingressus</i> , e – <i>U. s. eremus</i> , l – <i>U. s. ladinicus</i> . Point – males, square – females.....	26

- Fig. S8. Scatterplot of the first dimensions of “size” (E1) and “shape” (K1) morphospaces reproduced variation of mtt II in males and females: A, C – models with *U. arctos*; B – model without *U. arctos*; C – “size” morphospace; D – NJ tree; E – UGMA dendrogram (cophenetic correlation – 0.92); F – Sattath-Tversky (Sattath, Tversky, 1977) additive tree. All classifications based on the coordinates of samples’ centroids in the “size” (E1, E2) and “shape” (K1, K2) morphospaces (numbers near the nodes - bootstrap (1000 repeats) supports in %). Ellipses’ horizontal and vertical projection onto the E1 (E2) and K1 axes are equal to the “sample mean” (centroid)  $\pm$  “sample range”  $\times$  0.95.....28
- Fig. S9. Scatterplot of the first dimensions of “size” (E1) and “shape” (K1) morphospaces reproduced variation of mtt II in males: A, C – models with *U. arctos*; B – model without *U. arctos*; C – “size” morphospace; D – NJ tree; E – UGMA dendrogram (cophenetic correlation – 0.90); F – Sattath-Tversky (Sattath, Tversky, 1977) additive tree. All classifications based on the coordinates of samples’ centroids in the “size” (E1, E2) and “shape” (K1, K2) morphospaces (numbers near the nodes - bootstrap (1000 repeats) supports in %). Ellipses’ horizontal and vertical projection onto the E1 (E2) and K1 axes are equal to the “sample mean” (centroid)  $\pm$  “sample range”  $\times$  0.95.....30
- Fig. S10. Scatterplot of the first dimensions of “size” (E1) and “shape” (K1) morphospaces reproduced variation of mtt II in females: A, C – models with *U. arctos*; B – model without *U. arctos*; C – “size” morphospace; D – NJ tree; E – UGMA dendrogram (cophenetic correlation – 0.86); F – Sattath-Tversky (Sattath, Tversky, 1977) additive tree. All classifications based on the coordinates of samples’ centroids in the “size” (E1, E2) and “shape” (K1, K2) morphospaces (numbers near the nodes - bootstrap (1000 repeats) supports in %). Ellipses’ horizontal and vertical projection onto the E1 (E2) and K1 axes are equal to the “sample mean” (centroid)  $\pm$  “sample range”  $\times$  0.95.....32
- Fig. S11. The scatterplots of measures (GL – Dd) of mtt III and their UPMGA classification, and single linkage dendrograms of measurements based on the correlation metric. et – *U. etruscus*, a – *U. arctos*, r – *U. rossicus*, d – *U. deningeri*, pk – *U. k. praekudarensis*, ku – *U. k. kudarensis*, s – *U. s. spelaeus*, k – *U. k. kanivetz*, U, i – *U. k. ingressus*, e – *U. s. eremus*, l – *U. s. ladinicus*.. 37
- Fig. S12. The scatterplot of Index plumpness (ip) and GL of mtt III: et – *U. etruscus*, a – *U. arctos*, r – *U. rossicus*, d – *U. deningeri*, pk – *U. k. praekudarensis*, ku – *U. k. kudarensis*, s – *U. s. spelaeus*, k – *U. k. kanivetz*, U, i – *U. k. ingressus*, e – *U. s. eremus*, l – *U. s. ladinicus*. Point – males, square – females.....39
- Fig. S13. Scatterplot of the first dimensions of “size” (E1) and “shape” (K1) morphospaces reproduced variation of mtt III in males and females: A – models with *U. arctos*; B – model without *U. arctos*; C – NJ tree; D – UGMA dendrogram (cophenetic correlation – 0.96); E – Sattath-Tversky (Sattath, Tversky, 1977) additive tree. All classifications based on the coordinates of samples’ centroids in the “size” (E) and “shape” (K1, K2) morphospaces (numbers near the nodes - bootstrap (1000 repeats) supports in %). Ellipses’ horizontal and vertical projection onto the E1 and K1 axes are equal to the “sample mean” (centroid)  $\pm$  “sample range”  $\times$  0.95.....40
- Fig. S14. Scatterplot of the first dimensions of “size” (E1) and “shape” (K1) morphospaces reproduced variation of mtt III in males: A – models with *U. arctos*; B – model without *U. arctos*; C – NJ tree; D – UGMA dendrogram (cophenetic correlation – 0.95); E – Sattath-Tversky (Sattath, Tversky, 1977) additive tree. All classifications based on the coordinates of samples’ centroids in the “size” (E) and “shape” (K1, K2) morphospaces (numbers near the nodes - bootstrap (1000 repeats) supports in %). Ellipses’ horizontal and vertical projection onto the E1 and K1 axes are equal to the “sample mean” (centroid)  $\pm$  “sample range”  $\times$  0.95.....42
- Fig. S15. Scatterplot of the first dimensions of “size” (E1) and “shape” (K1) morphospaces reproduced variation of mtt III in females: A – models with *U. arctos*; B – model without *U. arctos*; C – NJ tree; D – UGMA dendrogram (cophenetic correlation – 0.95); E – Sattath-Tversky (Sattath, Tversky, 1977) additive tree. All classifications based on the coordinates of samples’ centroids in the “size” (E, E1, E2) and “shape” (K1, K2) morphospaces (numbers near



- the nodes - bootstrap (1000 repeats) supports in %). Ellipses' horizontal and vertical projection onto the E1 and K1 axes are equal to the "sample mean" (centroid)  $\pm$  "sample range"  $\times$  0.95. ...44
- Fig. S16. The scatterplots of measures (GL – Dd) of mtt IV and their UPMGA classification, and single linkage dendrograms of measurements based on the correlation metric. et – *U. etruscus*, a – *U. arctos*, r – *U. rossicus*, d – *U. deningeri*, pk – *U. k. praekudarensis*, ku – *U. k. kudarensis*, s – *U. s. spelaeus*, k – *U. k. kanivetz*, i – *U. k. ingressus*, e – *U. s. eremus*, l – *U. s. ladinicus*. .....49
- Fig. S17. The scatterplot of Index plumpness (ip) and GL of mtt IV: et – *U. etruscus*, a – *U. arctos*, r – *U. rossicus*, d – *U. deningeri*, pk – *U. k. praekudarensis*, ku – *U. k. kudarensis*, s – *U. s. spelaeus*, k – *U. k. kanivetz*, i – *U. k. ingressus*, e – *U. s. eremus*, l – *U. s. ladinicus*. Point – males, square – females.....51
- Fig. S18. Scatterplot of the first dimensions of "size" (E1) and "shape" (K1) morphospaces reproduced variation of mtt IV in males and females: A, C – models with *U. arctos*; B – model without *U. arctos*; C – "size" morphospace; D – NJ tree; E – UGMA dendrogram (cophenetic correlation – 0.85); F – Sattath-Tversky (Sattath, Tversky, 1977) additive tree. All classifications based on the coordinates of samples' centroids in the "size" (E1, E2) and "shape" (K1, K2) morphospaces (numbers near the nodes - bootstrap (1000 repeats) supports in %). Ellipses' horizontal and vertical projection onto the E1 (E2) and K1 axes are equal to the "sample mean" (centroid)  $\pm$  "sample range"  $\times$  0.95.....52
- Fig. S19. Scatterplot of the first dimensions of "size" (E1) and "shape" (K1) morphospaces reproduced variation of mtt IV in males: A, C – models with *U. arctos*; B – model without *U. arctos*; C – NJ tree; E – UGMA dendrogram (cophenetic correlation – 0.89); D – Sattath-Tversky (Sattath, Tversky, 1977) additive tree. All classifications based on the coordinates of samples' centroids in the "size" (E, E1, and E2) and "shape" (K1, K2) morphospaces (numbers near the nodes - bootstrap (1000 repeats) supports in %). Ellipses' horizontal and vertical projection onto the E1 (E2) and K1 axes are equal to the "sample mean" (centroid)  $\pm$  "sample range"  $\times$  0.95.....54
- Fig. S20. Scatterplot of the first dimensions of "size" (E1) and "shape" (K1) morphospaces reproduced variation of mtt IV in females: A, C – models with *U. arctos*; B – model without *U. arctos*; C – "size" morphospace; D – NJ tree; E – UGMA dendrogram (cophenetic correlation – 0.89); F – Sattath-Tversky (Sattath, Tversky, 1977) additive tree. All classifications based on the coordinates of samples' centroids in the "size" (E1, E2) and "shape" (K1, K2) morphospaces (numbers near the nodes - bootstrap (1000 repeats) supports in %). Ellipses' horizontal and vertical projection onto the E1 (E2) and K1 axes are equal to the "sample mean" (centroid)  $\pm$  "sample range"  $\times$  0.95.....56
- Fig. S21. The scatterplots of measures (GL – Dd) of mtt V and their classification: et – *U. etruscus*, a – *U. arctos*, sa – *U. savini*, r – *U. rossicus*, d – *U. deningeri*, pk – *U. k. praekudarensis*, ku – *U. k. kudarensis*, s – *U. s. spelaeus*, k – *U. k. kanivetz*, i – *U. k. ingressus*, e – *U. s. eremus*, l – *U. s. ladinicus*. .....60
- Fig. S22. The scatterplot of Index plumpness (ip) and GL of mtt V: et – *U. etruscus*, a – *U. arctos*, r – *U. rossicus*, d – *U. deningeri*, pk – *U. k. praekudarensis*, ku – *U. k. kudarensis*, s – *U. s. spelaeus*, k – *U. k. kanivetz*, i – *U. k. ingressus*, e – *U. s. eremus*, l – *U. s. ladinicus*. Point – males, square – females.....63
- Fig. S23. Scatterplot of the first dimensions of "size" (E1) and "shape" (K1) morphospaces reproduced variation of mtt V in males and females: A, C – models with *U. arctos*; B – model without *U. arctos*; C – "size" morphospace; D – NJ tree; E – UGMA dendrogram (cophenetic correlation – 0.83); F – Sattath-Tversky (Sattath, Tversky, 1977) additive tree. All classifications based on the coordinates of samples' centroids in the "size" (E1, E2) and "shape" (K1, K2) morphospaces (numbers near the nodes - bootstrap (1000 repeats) supports in %). Ellipses' horizontal and vertical projection onto the E1 (E2) and K1 axes are equal to the "sample mean" (centroid)  $\pm$  "sample range"  $\times$  0.95.....65
- Fig. S24. Scatterplot of the first dimensions of "size" (E1) and "shape" (K1) morphospaces reproduced variation of mtt V in males: A, C – models with *U. arctos*; B – model without *U.*

*arctos*; C – “size” morphospace; D – NJ tree; E – UGMA dendrogram (cophenetic correlation – 0.89); F – Sattath-Tversky (Sattath, Tversky, 1977) additive tree. All classifications based on the coordinates of samples’ centroids in the “size” (E1, E2) and “shape” (K1, K2) morphospaces (numbers near the nodes - bootstrap (1000 repeats) supports in %). Ellipses’ horizontal and vertical projection onto the E1 (E2) and K1 axes are equal to the “sample mean” (centroid)  $\pm$  “sample range”  $\times$  0.95. ....67

Fig. S25. Scatterplot of the first dimensions of “size” (E1) and “shape” (K1) morphospaces reproduced variation of mtt V in females: A, C – models with *U. arctos*; B – model without *U. arctos*; C – “size” morphospace; D – NJ tree; E – UGMA dendrogram (cophenetic correlation – 0.95); F – Sattath-Tversky (Sattath, Tversky, 1977) additive tree. All classifications based on the coordinates of samples’ centroids in the “size” (E1, E2) and “shape” (K1, K2) morphospaces (numbers near the nodes - bootstrap (1000 repeats) supports in %). Ellipses’ horizontal and vertical projection onto the E1 (E2) and K1 axes are equal to the “sample mean” (centroid)  $\pm$  “sample range”  $\times$  0.95. ....69

## List of Tables

Table S1. Sample numbers (N), means (M), and standard errors (m) of the variables of mtt I among different forms of bears .....	8
Table S2. Sexual size dimorphism (SSD and ASSD) of mtt I in the different forms of cave bears and brown bear; <i>p</i> based on Mann-Whitney U Test; <i>v</i> , % - relative variance associated with SSD. ....	8
Table S3. Statistical parameters of measures of mtt I among different bears and sexes: m – males, f – females. ....	11
Table S4. Kruskal-Wallis test <i>z'</i> values (males - above diagonal and females – under diagonal) for measures of mtt I. The statistical significance values, according to 2-tailed <i>p</i> values, have been underlined. ....	12
Table S5. Description of the modeled morphological spaces for cave bears and brown bear mtt I. Correlation coefficients among the measures and dimensions of two morphospace models (MDS axes: E1–E3, K1–K3); $r^2$ – coefficients of determination in the linear multiple regression models. ....	14
Table S6. Description of the modeled morphological spaces of mtt I for males of cave bears and brown bear. Correlation coefficients among the measures and dimensions of two morphospace models (MDS axes: E1–E2, K1–K2); $r^2$ – coefficients of determination in the linear multiple regression models. ....	16
Table S7. Description of the modeled morphological spaces of mtt I for females of cave bears and brown bear. Correlation coefficients among the measures and dimensions of two morphospace models (MDS axes: E1–E2, K1–K2); $r^2$ – coefficients of determination in the linear multiple regression models. ....	18
Table S8. Sample numbers (N), means (M), and standard errors (m) of the variables of mtt II among different forms of bears .....	20
Table S9. Sexual size dimorphism (SSD and ASSD) of mtt II in the different forms of cave bears and brown bear ; <i>p</i> based on Mann-Whitney U Test; <i>v</i> , % - relative variance associated with SSD. ....	20
Table S10. Kruskal-Wallis test <i>z'</i> values (males - above diagonal and females – under diagonal) for measures of mtc II. The statistical significance values, according to 2-tailed <i>p</i> values, have been underlined. ....	22
Table S11. Statistical parameters of measures of mtt II among different bears and sexes: m – males, f – females. ....	25
Table S12. Description of the modeled morphological spaces for cave bears and brown bear mtt II. Correlation coefficients among the measures and dimensions of two morphospace models	

(MDS axes: E1–E2, K1–K2); $r^2$ – coefficients of determination in the linear multiple regression models. ....	27
Table S13. Description of the modeled morphological spaces for males of cave bears and brown bear mtt II. Correlation coefficients among the measures and dimensions of two morphospace models (MDS axes: E1–E2, K1–K2); $r^2$ – coefficients of determination in the linear multiple regression models. ....	29
Table S14. Description of the modeled morphological spaces for females of cave bears and brown bear mtt II. Correlation coefficients among the measures and dimensions of two morphospace models (MDS axes: E1–E2, K1–K2); $r^2$ – coefficients of determination in the linear multiple regression models. ....	31
Table S15. Sample numbers (N), means (M), and standard errors (m) of the variables of mtt III among different forms of bears ....	33
Table S16. Sexual size dimorphism (SSD and ASSD) of mtt III in the different forms of cave bears and brown bear ; $p$ based on Mann-Whitney U Test; $v$ , % - relative variance associated with SSD. ....	33
Table S17. Kruskal-Wallis test $z'$ values (males - above diagonal and females – under diagonal) for measures of mtt III. The statistical significance values, according to 2-tailed $p$ values, have been underlined. ....	35
Table S18. Statistical parameters of measures of mtt III among different bears and sexes: m – males, f – females. ....	38
Table S19. Description of the modeled morphological spaces for males of cave bears and brown bear mtt III. Correlation coefficients among the measures and dimensions of two morphospace models (MDS axes: E, K1–K2); $r^2$ – coefficients of determination in the linear multiple regression models. ....	39
Table S20. Description of the modeled morphological spaces for males of cave bears and brown bear mtt III. Correlation coefficients among the measures and dimensions of two morphospace models (MDS axes: E, K1–K3); $r^2$ – coefficients of determination in the linear multiple regression models. ....	41
Table S21. Description of the modeled morphological spaces for females of cave bears and brown bear mtt III. Correlation coefficients among the measures and dimensions of two morphospace models (MDS axes: E, E1–E2, K1–K2); $r^2$ – coefficients of determination in the linear multiple regression models. ....	43
Table S22. Sample numbers (N), means (M), and standard errors (m) of the variables of mtt IV among the different forms of bears. ....	45
Table S23. Sexual size dimorphism (SSD and ASSD) of mtt IV in the different forms of cave bears and brown bear; $p$ based on Mann-Whitney U Test; $v$ , % - relative variance associated with SSD. ....	45
Table S24. Kruskal-Wallis test $z'$ values (males - above diagonal and females – under diagonal) for measures of mtt IV. The statistical significance values, according to 2-tailed $p$ values, have been underlined. ....	47
Table 26. Description of the modeled morphological spaces for cave bears and brown bear mtt IV. Correlation coefficients among the measures and dimensions of two morphospace models (MDS axes: E1–E2, K1–K2); $r^2$ – coefficients of determination in the linear multiple regression models. ....	51
Table S27. Description of the modeled morphological spaces for males of cave bears and brown bear metatarsal IV. Correlation coefficients among the measures and dimensions of two morphospace models (MDS axes: E1–E2, K1–K3); $r^2$ – coefficients of determination in the linear multiple regression models. ....	53
Table S28. Description of the modeled morphological spaces for females of cave bears and brown bear mtt IV. Correlation coefficients among the measures and dimensions of two morphospace models (MDS axes: E, K1–K2); $r^2$ – coefficients of determination in the linear multiple regression models. ....	55

Table S29. Sample numbers (N), means (M), and standard errors (m) of the variables of mtt V among different forms of bears .....	57
Table S30. Sexual size dimorphism ( <i>SSD</i> and <i>ASSD</i> ) of mtt V in the different forms of cave bears and brown bear; <i>p</i> based on Mann-Whitney U Test; <i>v</i> , % - relative variance associated with <i>SSD</i> . .....	58
Table S31. Statistical parameters of measures of mtt V among different bears and sexes: m – males, f – females. ....	61
Table S32. Kruskal-Wallis test <i>z'</i> values (males - above diagonal and females – under diagonal) for GL and BP of mtt V between bear taxa. The statistical significance values, according to 2-tailed <i>p</i> values, have been underlined. ....	62
Table S33. Description of the modeled morphological spaces for cave bears and brown bear mtt V. Correlation coefficients among the measures and dimensions of two morphospace models (MDS axes: E1–E2, K1–K2); $r^2$ – coefficients of determination in the linear multiple regression models. ....	64
Table S34. Description of the modeled morphological spaces for males of cave bears and brown bear mtt V (males only). Correlation coefficients among the measures and dimensions of two morphospace models (MDS axes: E1–E2, K1–K2); $r^2$ – coefficients of determination in the linear multiple regression models. ....	66
Table S35. Description of the modeled morphological spaces for females of cave bears and brown bear mtt V. Correlation coefficients among the measures and dimensions of two morphospace models (MDS axes: E1–E2, K1–K3); $r^2$ – coefficients of determination in the linear multiple regression models. ....	68

**METATARSAL BONE I (MTT I)****Males and females**

Table S1. Sample numbers (N), means (M), and standard errors (m) of the variables of mtt I among different forms of bears

Form	GL		Bp		Dp		SD	
	N	M±m	N	M±m	N	M±m	N	M±m
<i>U. deningeri</i>	30	55.5±0.68	30	23.9±0.44	30	25.9±0.62	30	12.2±0.26
<i>U. k. praekudarensis</i>	26	61.2±0.91	27	26.4±0.51	28	26.5±0.56	29	13.5±0.24
<i>U. k. kudarensis</i>	96	60.7±0.40	95	26.7±0.17	102	29.2±0.26	100	13.3±0.10
<i>U. rossicus</i>	13	42.2±0.48	10	16.5±0.26	10	17.0±0.57	10	8.6±0.20
<i>U. s. spelaeus</i>	12	54.7±1.09	11	23.1±0.70	12	25.6±0.86	12	11.5±0.36
<i>U. k. kanivetz</i>	13	54.5±1.03	12	22.9±0.59	13	24.8±0.44	13	11.3±0.26
<i>U. s. eremus</i>	20	54.0±0.77	20	22.4±0.54	20	25.2±0.65	20	11.2±0.38
<i>U. k. ingressus</i>	38	56.6±0.56	13	24.3±0.58	13	23.8±0.66	38	17.5±0.25
<i>U. arctos</i>	24	64.8±1.51	24	20.8±0.59	18	21.7±0.93	24	9.7±0.37
			Bd		Dd			
			N	M±m	N	M±m		
<i>U. deningeri</i>	30	17.6±0.31	30	15.5±0.24				
<i>U. k. praekudarensis</i>	28	19.6±0.29	28	16.6±0.23				
<i>U. k. kudarensis</i>	98	19.5±0.14	94	15.9±0.11				
<i>U. rossicus</i>	13	13.5±0.29	9	11.3±0.18				
<i>U. s. spelaeus</i>	11	17.6±0.49	11	16.2±0.37				
<i>U. k. kanivetz</i>	13	17.2±0.41	13	15.6±0.27				
<i>U. s. eremus</i>	20	16.7±0.37	20	16.0±0.33				
<i>U. k. ingressus</i>	38	17.5±0.25	31	16.7±0.22				
<i>U. arctos</i>	24	16.2±0.55	17	13.7±0.47				

**Sexual size dimorphism**Table S2. Sexual size dimorphism (SSD and ASSD) of mtt I in the different forms of cave bears and brown bear; *p* based on Mann-Whitney U Test; *v*, % - relative variance associated with SSD.

	Measures						ASSD
	GL	Bp	Dp	SD	Bd	Dd	
	<i>U. deningeri</i>						
Males	57.1±0.69	25.3±0.39	27.9±0.60	13.1±0.28	18.5±0.26	16.3±0.20	
Females	53.1±1.04	21.7±0.45	23.0±0.62	10.8±0.21	16.1±0.36	14.4±0.31	
SSD	3.7±1.13	7.8±1.27	9.6±1.71	9.5±1.48	7.0±1.30	6.0±1.20	7.3
<i>v</i> , %	( <i>p</i> =0.004)	( <i>p</i> <0.001)	( <i>p</i> <0.001)	( <i>p</i> <0.001)	( <i>p</i> <0.001)	( <i>p</i> <0.001)	
	42.2	71.3	66.8	70.5	67.2	65.0	
	<i>U. rossicus</i>						
Males	43.9±0.29	17.0±0.43	18.9±1.06	9.1±0.29	14.7±0.22	11.6±0.42	
Females	41.2±0.45	16.3±0.31	16.1±0.41	8.4±0.21	12.7±0.1	11.2±0.18	
SSD	3.2±0.63	n.s.	n.s.	n.s.	7.1±0.89	n.s.	4.4
<i>v</i> , %	( <i>p</i> =0.004)	-	-	-	( <i>p</i> =0.004)	-	
	69.5	-	-	-	92.0	-	
	<i>U. k. praekudarensis</i>						
Males	63.1±0.65	27.4±0.4	27.3±0.56	13.9±0.21	20.0±0.21	17.2±0.15	
Females	55.0±1.61	22.9±0.81	23.4±0.86	12.1±0.56	17.8±0.86	14.8±0.31	
SSD	6.8±1.48	8.9±1.8	7.7±2.03	6.7±2.30	5.8±2.33	7.5±1.08	7.2

	Measures						ASSD
	GL	Bp	Dp	SD	Bd	Dd	
	(p<0.001)	(p<0.001)	(p=0.006)	(p=0.01)	(p=0.02)	(p<0.001)	
v, %	75.6	72.4	55.6	51.8	54.6	84.2	
	<i>U. k. kudarensis</i>						
Males	66.1±0.44	27.5±0.19	30.7±0.26	13.8±0.10	20.0±0.17	16.3±0.15	
Females	61.9±0.55	26.1±0.25	27.8±0.35	12.9±0.15	19.0±0.20	15.5±0.13	
SSD	3.3±0.37	2.5±0.58	5.0±0.74	3.2±0.67	2.7±0.66	2.5±0.62	3.3
	(p<0.001)	(p<0.001)	(p<0.001)	(p<0.001)	(p<0.001)	(p<0.001)	
v, %	72.7	23.7	45.2	28.0	23.1	19.7	
	<i>U. s. spelaeus</i>						
Males	59.2±0.78	25.6±0.56	28.1±0.56	12.9±0.32	19.1±0.41	17.5±0.35	
Females	52.5±0.74	21.7±0.54	24.4±1.02	10.8±0.28	16.8±0.52	15.4±0.26	
SSD	6.0±0.96	8.2±1.64	7.0±2.22	8.8±1.80	6.4±1.84	6.3±1.32	7.1
	(p=0.008)	(p=0.01)	n.s.	(p=0.008)	(p=0.02)	(p=0.01)	
v, %	83.4	80.5	47.7	76.7	61.4	81.0	
	<i>U. s. eremus</i>						
Males	56.9±0.60	24.4±0.61	27.3±0.79	12.5±0.43	18.1±0.39	17.1±0.38	
Females	51.1±0.58	20.5±0.23	23.1±0.40	9.8±0.16	15.4±0.19	14.9±0.19	
SSD	5.3±0.77	8.5±1.46	8.4±1.76	12.0±2.05	7.9±1.30	7.0±1.32	8.2
	(p<0.001)	(p<0.001)	(p=0.002)	(p<0.001)	(p<0.001)	(p=0.002)	
v, %	82.3	76.7	68.4	77.0	78.4	73.2	
	<i>U. k. ingressus</i>						
Males	59.6±0.47	25.4±0.62	24.0±0.95	12.9±0.29	18.8±0.21	17.5±0.20	
Females	54.2±0.52	22.6±0.61	23.5±0.92	11.1±0.20	16.5±0.25	15.8±0.26	
SSD	4.7±0.62	5.8±1.81		7.4±1.48	6.5±0.93	5.0±0.98	5.1
	(p<0.001)	(p=0.004)	n.s.	(p<0.001)	(p<0.001)	(p<0.001)	
v, %	76.0	56.9	-	11.5	69.3	80.2	
	<i>U. kanivetz</i>						
Males	57.7±0.88	25.0±0.20	25.8±0.60	12.0±0.23	18.2±0.67	16.4±0.20	
Females	51.7±0.81	21.4±0.45	24.0±0.46	10.8±0.32	16.3±0.18	15.0±0.27	
SSD	5.5±1.01	7.7±1.06		5.3±1.71	5.5±2.01	4.7±1.08	5.4
	(p=0.003)	(p=0.006)	n.s.	(p=0.02)	(p=0.01)	(p=0.006)	
v, %	77.9	87.0		56.3	70.9	69.3	
	<i>U. arctos</i>						
Males	70.2±1.79	23.3±0.55	23.9±1.32	11.1±0.50	18.5±0.64	15.3±0.49	
Females	60.2±1.44	18.6±0.44	19.5±0.84	8.5±0.24	14.3±0.37	12.4±0.37	
SSD	7.6±1.75	11.1±1.70	10.3±3.62	13.1±2.84	12.8±2.26	10.5±2.24	10.9
	(p<0.001)	(p<0.001)	(p=0.01)	(p<0.001)	(p=0.004)	(p=0.001)	

Univariate analysis

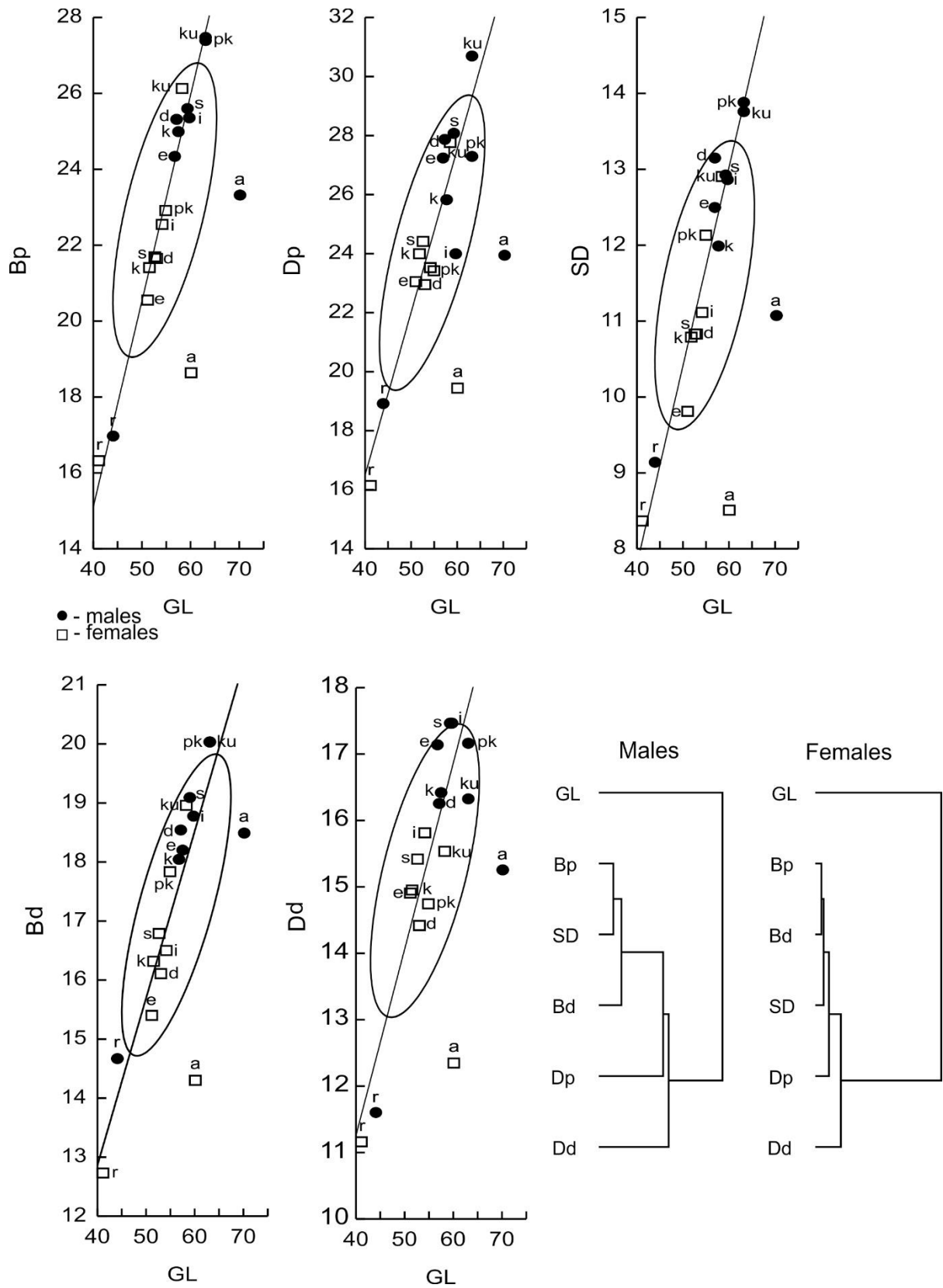

Fig. S1. The scatterplots of measures (GL – Dd) of mtt I and their UPMGA classification: et – *U. etruscus*, a – *U. arctos*, r – *U. rossicus*, d – *U. deningeri*, pk – *U. k. praekudarensis*, ku – *U. k. kudarensis*, s – *U. s. spelaeus*, k – *U. k. kanivetz*, i – *U. k. ingressus*, e – *U. s. eremus*, l – *U. s. ladinicus*.

Table S3. Statistical parameters of measures of mtt I among different bears and sexes: m – males, f – females.

Taxa	Sex	GL - N	GL	GL Std.Dev.	Bp - N	Bp	Bp Std.Dev.	Dp - N	Dp	Dp Std.Dev.	SD - N	SD	SD Std.Dev.	Bd - N	Bd	Bd Std.Dev.	Dd - N	Dd	Dd Std.Dev.
<i>U. rossicus</i>	f	8	41.2	1.26	7	16.3	0.83	7	16.1	1.08	7	8.4	0.56	8	12.7	0.27	6	11.2	0.45
	m	5	43.9	0.66	3	17.0	0.75	3	18.9	1.84	3	9.1	0.50	5	14.7	0.50	3	11.6	0.72
<i>U. deningeri</i>	f	12	53.1	3.60	12	21.7	1.56	12	23.0	2.15	12	10.8	0.72	12	16.1	1.26	12	14.4	1.07
	m	18	57.1	2.91	18	25.3	1.66	18	27.9	2.55	18	13.1	1.21	18	18.5	1.12	18	16.3	0.85
<i>U. k. praekudarensis</i>	f	6	55.0	3.95	6	22.9	1.98	6	23.4	2.11	6	12.1	1.37	6	17.8	2.10	6	14.8	0.75
	m	20	63.1	2.93	21	27.4	1.85	22	27.3	2.60	23	13.9	1.02	22	20.0	0.97	22	17.2	0.70
<i>U. k. kudarensis</i>	f	50	58.4	2.05	51	26.1	1.76	53	27.8	2.54	51	12.9	1.05	49	19.0	1.37	49	15.5	0.88
	m	46	63.3	2.28	44	27.5	1.25	49	30.7	1.79	49	13.8	0.69	49	20.0	1.17	45	16.3	1.02
<i>U. s. spelaeus</i>	f	8	52.5	2.09	7	21.7	1.42	8	24.4	2.88	8	10.8	0.79	7	16.8	1.37	7	15.4	0.68
	m	4	59.2	1.56	4	25.6	1.11	4	28.1	1.13	4	12.9	0.64	4	19.1	0.82	4	17.5	0.70
<i>U. k. ingressus</i>	f	21	54.2	2.39	5	22.6	1.36	5	23.5	2.06	21	11.1	0.91	21	16.5	1.15	15	15.8	0.99
	m	17	59.6	1.93	8	25.4	1.75	8	24.0	2.70	17	12.9	1.21	17	18.8	0.86	16	17.5	0.81
<i>U. k. kanivetz</i>	f	7	51.7	2.14	7	21.4	1.19	7	24.0	1.21	7	10.8	0.84	7	16.3	0.49	7	15.0	0.72
	m	6	57.7	2.17	5	25.0	0.45	6	25.8	1.47	6	12.0	0.56	6	18.2	1.64	6	16.4	0.49
<i>U. s. eremus</i>	f	10	51.1	1.84	10	20.5	0.72	10	23.1	1.26	10	9.8	0.51	10	15.4	0.59	10	14.9	0.61
	m	10	56.9	1.89	10	24.4	1.94	10	27.3	2.49	10	12.5	1.35	10	18.1	1.23	10	17.1	1.19
<i>U. arctos</i>	f	13	60.2	5.08	13	18.6	1.59	9	19.5	2.52	13	8.5	0.86	13	14.3	1.32	9	12.4	1.12
	m	11	70.2	5.93	11	23.3	1.84	9	23.9	3.96	11	11.1	1.65	11	18.5	2.11	8	15.3	1.39



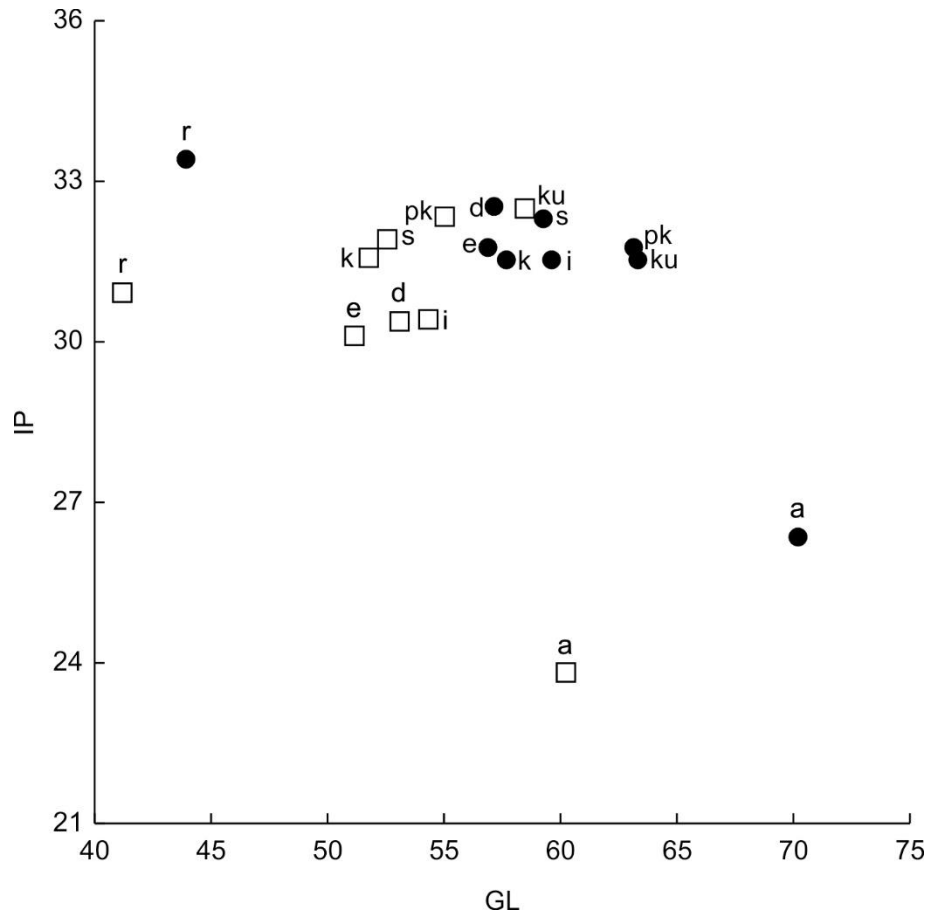

Fig. S2. The scatterplot of Index plumpness (ip) and GL of mtt I: et – *U. etruscus*, a – *U. arctos*, r – *U. rossicus*, sa – *U. savini*, d – *U. deningeri*, pk – *U. k. praekudarensis*, ku – *U. k. kudarensis*, s – *U. s. spelaeus*, k – *U. k. kanivetz*, i – *U. k. ingressus*, e – *U. s. eremus*, l – *U. s. ladinicus*. Point – males, square – females

Table S4. Kruskal-Wallis test z' values (males - above diagonal and females – under diagonal) for measures of mtt I. The statistical significance values, according to 2-tailed *p* values, have been underlined.

Taxa	1	2	3	4	5	6	7	8	9
	GL								
<i>U. deningeri</i>	1	1.32	<u>4.6</u>	<u>5.79</u>	0.64	1.57	0.11	0.37	<u>6.23</u>
<i>U. rossicus</i>	2	2.32	<u>4.33</u>	<u>4.84</u>	1.52	2.36	1.19	0.96	<u>5.66</u>
<i>U. k. praekudarensis</i>	3	0.97	2.86	0.43	2.09	2.92	3.1	<u>4.23</u>	2.37
<i>U. k. kudarensis</i>	4	<u>4.01</u>	<u>6.17</u>	1.86	2.41	<u>3.8</u>	<u>3.59</u>	<u>5.03</u>	2.31
<i>U. s. spelaeus</i>	5	0.44	1.72	1.27	<u>3.92</u>	0.33	0.46	0.84	<u>3.48</u>
<i>U. k. ingressus</i>	6	0.61	3.09	0.56	<u>4.10</u>	1.02	1.01	1.7	<u>4.79</u>
<i>U. k. kanivetz</i>	7	0.62	1.48	1.40	<u>3.92</u>	0.18	1.18	0.38	<u>4.59</u>
<i>U. s. eremus</i>	8	0.99	1.34	1.76	<u>4.94</u>	0.47	1.68	0.26	<u>5.79</u>
<i>U. arctos</i>	9	<u>3.91</u>	<u>5.84</u>	2.19	0.89	<u>3.94</u>	<u>3.81</u>	<u>3.97</u>	<u>4.73</u>
	Bp								
<i>U. deningeri</i>	1	1.96	<u>3.07</u>	<u>4.15</u>	0.16	0.26	0.60	0.80	1.81
<i>U. rossicus</i>	2	2.49	<u>3.58</u>	<u>4.00</u>	1.72	1.97	1.26	1.38	0.82
<i>U. k. praekudarensis</i>	3	0.68	2.74	0.66	1.64	2.11	2.59	<u>3.38</u>	<u>4.51</u>
<i>U. k. kudarensis</i>	4	<u>4.14</u>	<u>6.23</u>	2.28	2.05	2.74	3.10	<u>4.21</u>	<u>5.50</u>
<i>U. s. spelaeus</i>	5	0.01	2.22	0.61	<u>3.28</u>	0.03	0.58	0.68	1.34
<i>U. k. ingressus</i>	6	0.51	2.49	0.12	2.25	0.46	0.72	0.89	1.72
<i>U. k. kanivetz</i>	7	0.20	2.04	0.78	<u>3.52</u>	0.18	0.62	0.02	0.72

Taxa		1	2	3	4	5	6	7	8	9
<i>U. s. eremus</i>	8	0.94	1.59	1.44	<u>5.00</u>	0.82	1.23	0.63		0.86
<i>U. arctos</i>	9	2.06	0.77	2.36	<u>6.92</u>	1.76	2.08	1.56	1.00	
Dp										
<i>U. deningeri</i>	1		2.37	0.46	<u>3.76</u>	0.06	2.24	1.49	0.36	2.02
<i>U. rossicus</i>	2	2.21		2.16	<u>4.23</u>	1.98	0.78	1.10	2.03	0.98
<i>U. k. praekudarensis</i>	3	0.10	1.98		<u>4.61</u>	0.33	1.95	1.20	<u>0.01</u>	<u>1.72</u>
<i>U. k. kudarensis</i>	4	<u>4.25</u>	<u>5.99</u>	3.04		1.93	<u>5.22</u>	<u>4.02</u>	<u>3.40</u>	<u>5.14</u>
<i>U. s. spelaeus</i>	5	0.83	2.77	0.61	2.58		1.61	1.14	0.30	1.43
<i>U. k. ingressus</i>	6	0.15	1.93	0.05	2.73	0.53		0.47	1.71	0.26
<i>U. k. kanivetz</i>	7	0.53	2.43	0.36	2.76	0.25	0.29		1.08	0.24
<i>U. s. eremus</i>	8	0.14	2.01	0.21	<u>4.12</u>	0.93	0.26	0.63		1.49
<i>U. arctos</i>	9	1.59	0.70	1.42	<u>5.71</u>	2.23	1.40	1.89	1.39	
SD										
<i>U. deningeri</i>	1		2.51	1.93	2.08	0.48	0.43	2.10	0.93	2.78
<i>U. rossicus</i>	2	2.40		<u>3.54</u>	<u>3.60</u>	1.70	2.27	0.82	1.82	0.78
<i>U. k. praekudarensis</i>	3	1.62	<u>3.51</u>		0.13	1.61	2.35	<u>3.48</u>	2.57	<u>4.55</u>
<i>U. k. kudarensis</i>	4	<u>3.92</u>	<u>5.96</u>	1.04		1.61	2.55	<u>3.61</u>	2.71	<u>4.90</u>
<i>U. s. spelaeus</i>	5	0.01	2.20	1.51	<u>3.32</u>		0.22	1.12	0.17	1.36
<i>U. k. ingressus</i>	6	0.44	2.99	1.41	<u>4.24</u>	0.40		1.78	0.56	2.38
<i>U. k. kanivetz</i>	7	0.11	2.04	1.55	<u>3.26</u>	0.09	0.49		1.20	0.15
<i>U. s. eremus</i>	8	1.45	1.06	2.77	<u>5.44</u>	1.30	2.04	1.16		1.59
<i>U. arctos</i>	9	2.68	0.15	<u>3.82</u>	<u>7.50</u>	2.38	<u>3.49</u>	2.17	1.07	
Bd										
<i>U. deningeri</i>	1		2.13	<u>3.71</u>	<u>4.08</u>	0.83	0.51	0.34	0.54	0.79
<i>U. rossicus</i>	2	2.53		<u>4.56</u>	<u>4.69</u>	2.29	2.46	1.52	1.58	2.56
<i>U. k. praekudarensis</i>	3	1.55	<u>3.57</u>		0.22	1.32	3.12	2.91	<u>3.66</u>	2.38
<i>U. k. kudarensis</i>	4	<u>4.22</u>	<u>6.59</u>	1.35		1.27	<u>3.37</u>	2.97	<u>3.86</u>	2.47
<i>U. s. spelaeus</i>	5	0.65	2.83	0.84	2.60		0.52	0.96	1.14	0.28
<i>U. k. ingressus</i>	6	0.52	<u>3.23</u>	1.27	<u>4.49</u>			0.70	0.98	0.33
<i>U. k. kanivetz</i>	7	0.10	2.33	1.30	<u>3.24</u>	0.28			0.11	0.91
<i>U. s. eremus</i>	8	1.09	1.45	2.40	<u>5.26</u>	0.49	0.32	1.05		1.18
<i>U. arctos</i>	9	1.84	0.93	3.06	<u>6.71</u>	1.57	1.70	1.68	0.64	
Dd										
<i>U. deningeri</i>	1		2.18	2.75	0.00	2.24	3.38	0.11	2.19	1.38
<i>U. rossicus</i>	2	2.24		3.63	2.28	3.41	4.01	2.00	3.38	1.14
<i>U. k. praekudarensis</i>	3	0.31	2.21		3.37	0.67	0.87	1.79	0.03	3.54
<i>U. k. kudarensis</i>	4	2.84	<u>4.71</u>	1.76		2.38	4.00	0.12	2.47	1.53
<i>U. s. spelaeus</i>	5	1.77	<u>3.53</u>	1.23	0.18		0.14	1.84	0.64	2.98
<i>U. k. ingressus</i>	6	3.08	<u>4.79</u>	2.15	0.94	0.76		2.32	0.74	4.04
<i>U. k. kanivetz</i>	7	0.65	2.57	0.27	1.51	1.00	1.93		1.57	1.18
<i>U. s. eremus</i>	8	0.53	2.61	0.14	1.99	1.25	2.37	0.16		3.06
<i>U. arctos</i>	9	2.06	0.40	2.02	<u>5.04</u>	<u>3.48</u>	<u>4.99</u>	2.42	2.47	

**Multivariate analyses**

Table S5. Description of the modeled morphological spaces for cave bears and brown bear mtt I. Correlation coefficients among the measures and dimensions of two morphospace models (MDS axes: E1–E3, K1–K3);  $r^2$  – coefficients of determination in the linear multiple regression models.

Measures	Morphospaces with <i>U. arctos</i>					Morphospaces without <i>U. arctos</i>					$r^2$
	“Size”		“Shape”		$r^2$	“Size”		“Shape”		$r^2$	
	morphospace	morphospace	morphospace	morphospace		morphospace	morphospace				
	E1	E2	K1	K2		E1	E2	K1	K2	K3	
GL	0.86	0.35	0.11	-0.35	0.74	0.88	-0.21	-0.14	0.21	0.36	0.91
Bp	0.95	0.18	0.30	-0.53	0.93	0.95	-0.02	-0.28	0.45	0.20	0.93
Dp	0.86	-0.26	0.58	-0.15	0.96	0.85	0.38	-0.52	0.08	-0.12	0.97
SD	0.95	0.05	0.33	-0.54	0.93	0.94	0.09	-0.30	0.56	-0.12	0.96
Bd	0.95	0.26	0.21	-0.53	0.91	0.95	-0.10	-0.20	0.45	0.15	0.90
Dd	0.77	0.61	-0.23	-0.21	0.85	0.78	-0.52	0.32	0.18	-0.03	0.95
ip	0.37	-0.12	0.29	-0.38		0.33	0.21	-0.21	0.47	-0.30	
Relative variance (%) of dimensions associated with taxonomical composition											
	64.4	51.24	43.1	55.1		68.2	41.0	51.7	23.5	12.6	

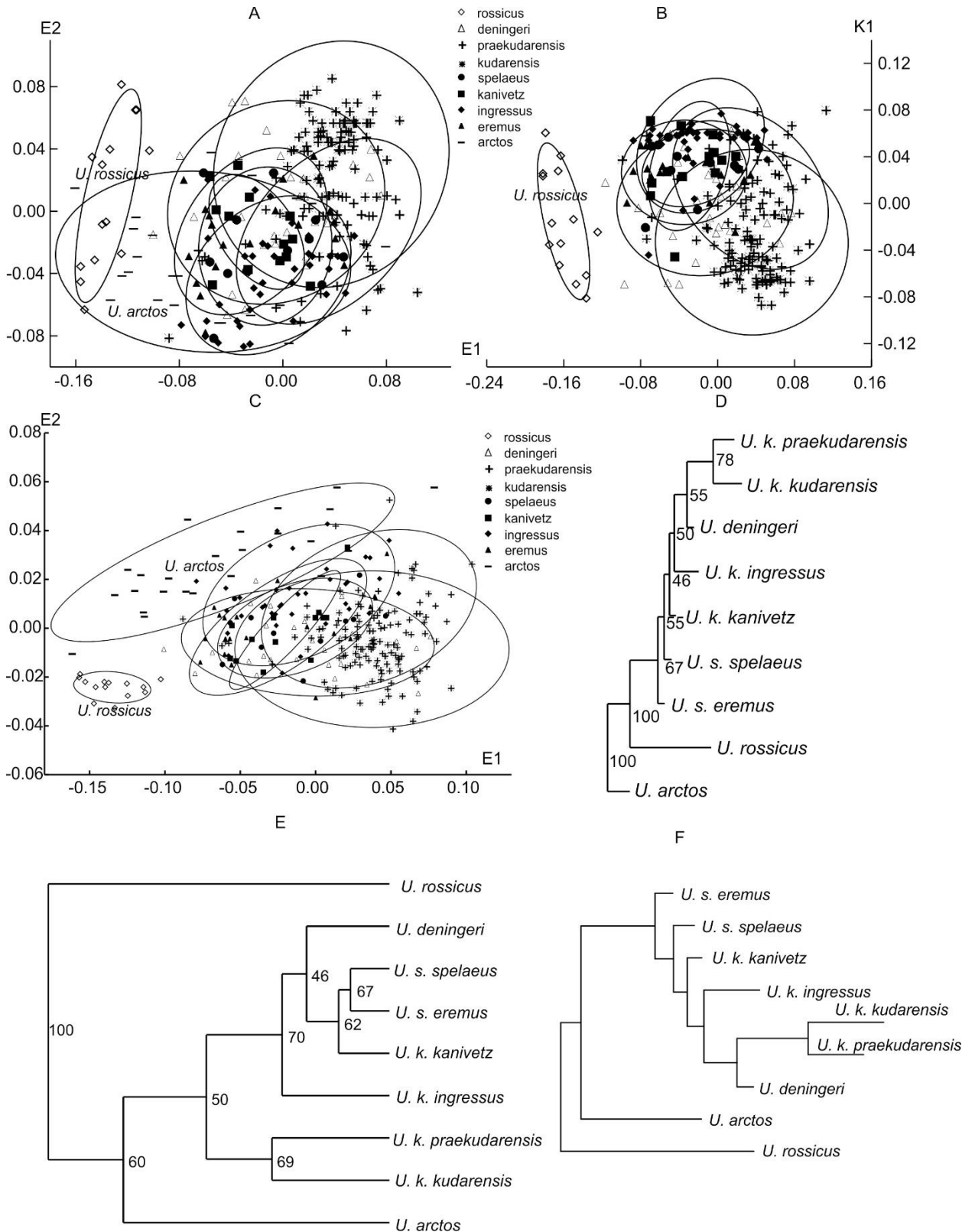

Fig. S3. Scatterplot of the first dimensions of "size" (E1) and "shape" (K1) morphospaces reproduced variation of mtt I in males and females: A, C – models with *U. arctos*; B – model without *U. arctos*; C – "size" morphospace; D – NJ tree; E – UGMA dendrogram (cophenetic correlation = 0.89); F – Sattath-Tversky (Sattath, Tversky, 1977) additive tree. All classifications based on the coordinates of samples' centroids in the "size" (E1, E2) and "shape" (K1, K2) morphospaces (numbers near the nodes - bootstrap (1000 repeats) supports in %). Ellipses' horizontal and vertical projection onto the E1 (E2) and K1 axes are equal to the "sample mean" (centroid)  $\pm$  "sample range"  $\times 0.95$ .

**Males**

Table S6. Description of the modeled morphological spaces of mtt I for males of cave bears and brown bear. Correlation coefficients among the measures and dimensions of two morphospace models (MDS axes: E1–E2, K1–K2);  $r^2$  – coefficients of determination in the linear multiple regression models.

Measures	Morphospaces with <i>U. arctos</i>					Morphospaces without <i>U. arctos</i>					
	“Size” morphospace		“Shape” morphospace		$r^2$	“Size” morphospace		“Shape” morphospace			$r^2$
	E1	E2	K1	K2		E1	E2	K1	K2	K3	
GL	0.51	0.47	0.05	0.45	0.66	0.79	-0.25	-0.13	-0.45	0.29	0.89
Bp	0.91	0.01	0.22	-0.04	0.84	0.91	0.03	-0.15	-0.03	0.47	0.84
Dp	0.81	-0.45	0.57	-0.31	0.88	0.75	0.58	-0.56	0.20	0.02	0.94
SD	0.91	-0.16	0.18	-0.45	0.87	0.88	0.19	-0.09	0.40	0.38	0.91
Bd	0.88	0.20	0.10	0.01	0.81	0.88	-0.09	-0.02	-0.04	0.48	0.82
Dd	0.66	0.50	-0.45	-0.09	0.79	0.62	-0.57	0.52	-0.07	-0.05	0.88
ip	0.13	-0.05	0.02	-0.13		0.06	-0.15	-0.11	-0.53	0.30	
Relative variance (%) of dimensions associated with taxonomical composition											
	73.2	58.0	48.9	51.9		82.5	48.6	58.4	7.7	29.7	

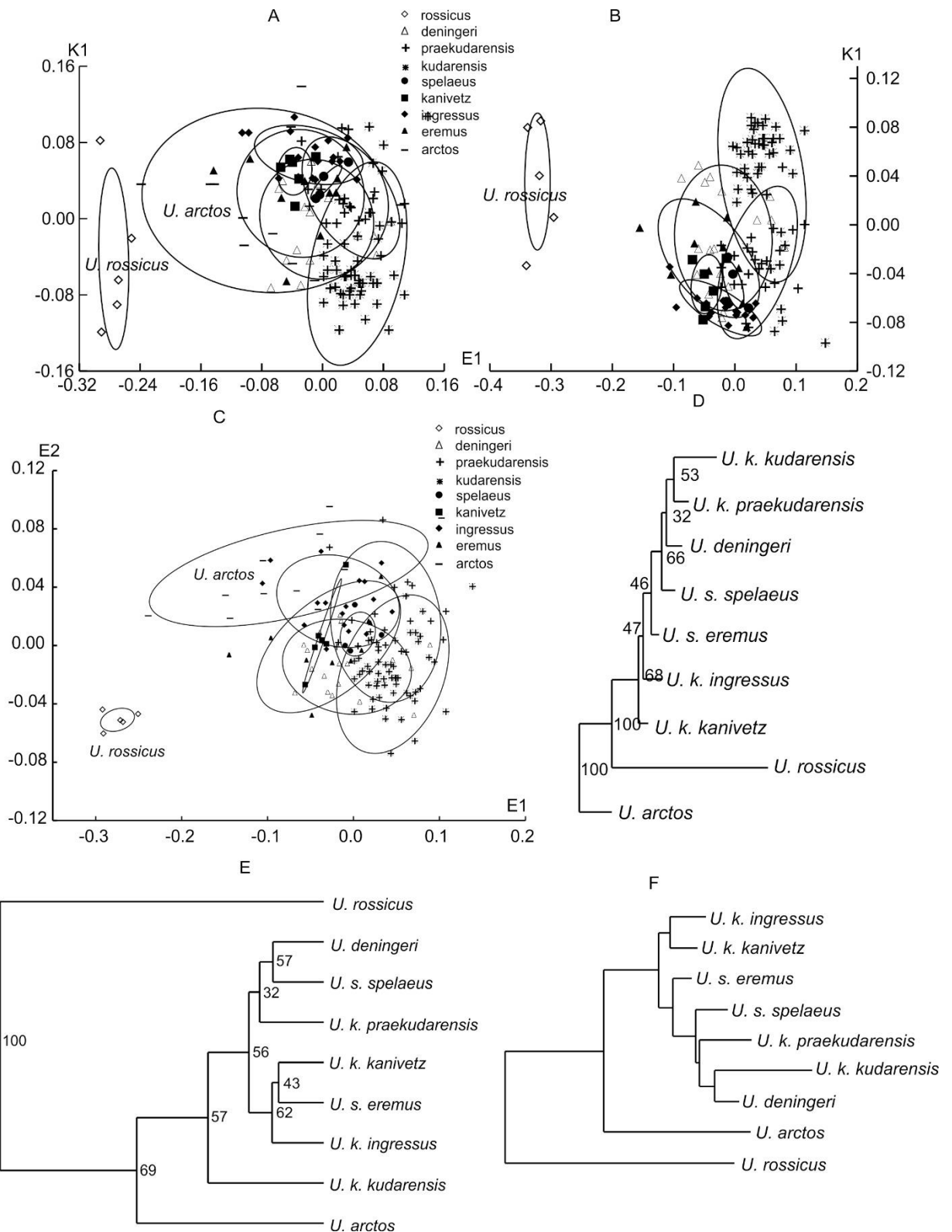

Fig. S4. Scatterplot of the first dimensions of “size” (E1) and “shape” (K1) morphospaces reproduced variation of mtt I in males: A, C – models with *U. arctos*; B – model without *U. arctos*; C – “size” morphospace; D – NJ tree; E – UGMA dendrogram (cophenetic correlation – 0.98); F – Sattath-Tversky (Sattath, Tversky, 1977) additive tree. All classifications based on the coordinates of samples’ centroids in the “size” (E1, E2) and “shape” (K1, K2) morphospaces (numbers near the nodes - bootstrap (1000 repeats) supports in %). Ellipses’ horizontal and vertical projection onto the E1 (E2) and K1 axes are equal to the “sample mean” (centroid)  $\pm$  “sample range”  $\times$  0.95.

## Females

Table S7. Description of the modeled morphological spaces of mtt I for females of cave bears and brown bear. Correlation coefficients among the measures and dimensions of two morphospace models (MDS axes: E1–E2, K1–K2);  $r^2$  – coefficients of determination in the linear multiple regression models.

Measures	Morphospaces with <i>U. arctos</i>					$r^2$	Morphospaces without <i>U. arctos</i>				
	“Size” morphospace		“Shape” morphospace				“Size” morphospace		“Shape” morphospace		
	E1	E2	K1	K2	K3		E1	E2	K1	K2	
GL	0.63	0.65	-0.01	-0.12	0.33	0.84	0.91	-0.26	-0.08	0.30	0.87
Bp	0.97	0.06	0.55	-0.22	0.27	0.97	0.97	-0.05	-0.22	0.46	0.95
Dp	0.90	-0.20	0.54	0.27	0.14	0.97	0.87	0.33	-0.50	0.10	0.96
SD	0.95	-0.13	0.70	-0.20	0.00	0.97	0.94	0.10	-0.23	0.52	0.92
Bd	0.96	0.09	0.52	-0.21	0.19	0.92	0.96	-0.10	-0.13	0.39	0.91
Dd	0.83	0.17	0.22	-0.18	-0.13	0.81	0.80	-0.46	0.22	0.01	0.89
ip	0.54	-0.15	-0.66	0.03	0.19		0.50	0.34	-0.25	0.24	
Relative variance (%) of dimensions associated with taxonomical composition											
	84.7	56.1	34.1	12.7	24.2		85.6	28.7	17.8	36.7	

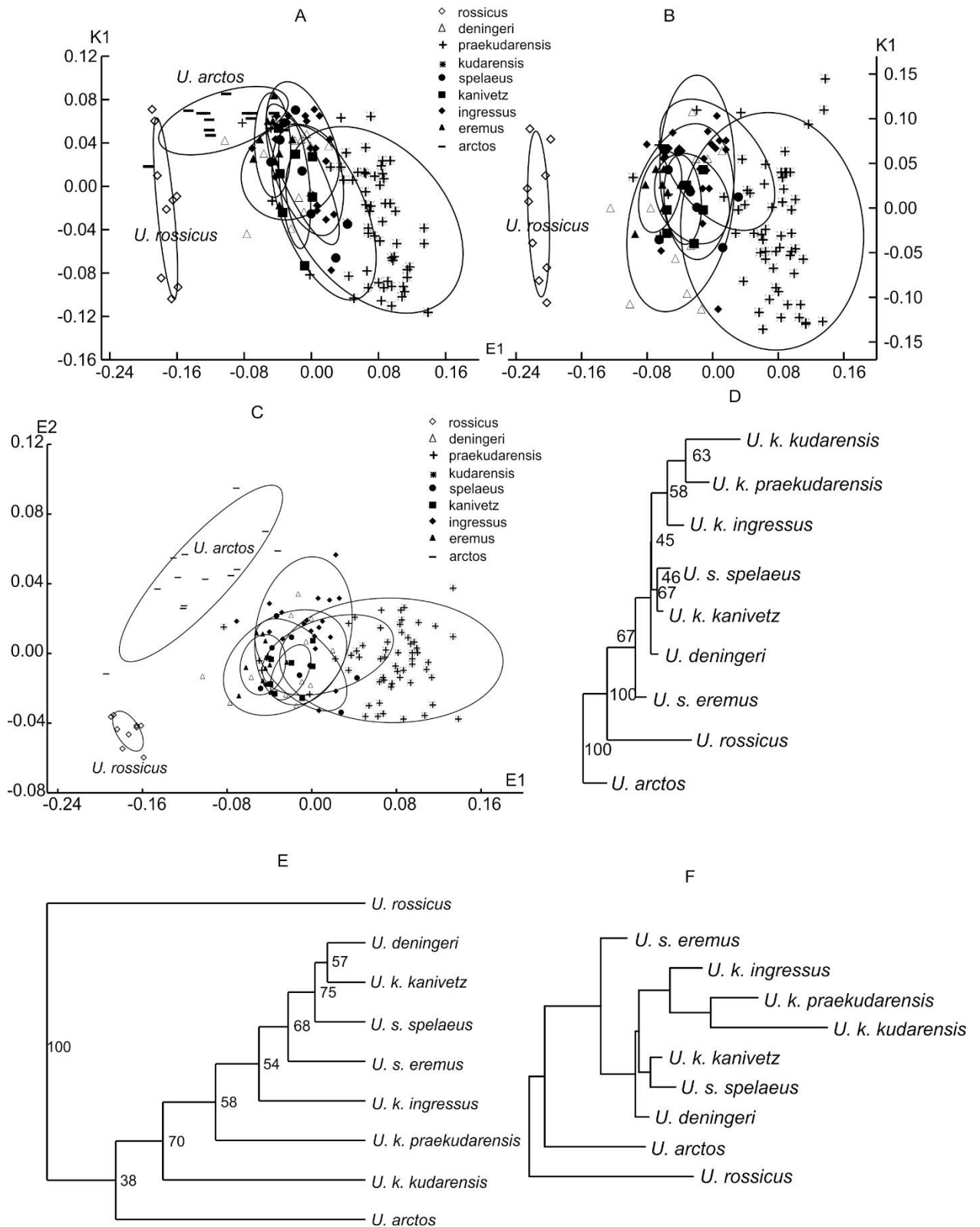

Fig. S5. Scatterplot of the first dimensions of "size" (E1) and "shape" (K1) morphospaces reproduced variation of mtt I in females: A, C – models with *U. arctos*; B – model without *U. arctos*; C – "size" morphospace; D – NJ tree; E – UGMA dendrogram (cophenetic correlation – 0.90); F – Sattath-Tversky (Sattath, Tversky, 1977) additive tree. All classifications based on the coordinates of samples' centroids in the "size" (E1, E2) and "shape" (K1, K2) morphospaces (numbers near the nodes - bootstrap (1000 repeats) supports in %). Ellipses' horizontal and vertical projection onto the E1 (E2) and K1 axes are equal to the "sample mean" (centroid) ± "sample range" x 0.95.



**METATARSAL BONE II (MTT II)****Males and females**

Table S8. Sample numbers (N), means (M), and standard errors (m) of the variables of mtt II among different forms of bears

Form	GL		Bp		Dp		SD	
	N	M±m	N	M±m	N	M±m	N	M±m
<i>U. etruscus</i>	1	60.5					1	11.5
<i>U. deningeri</i>	35	65.6±0.65	35	15.0±0.21	35	23.5±0.26	35	12.8±0.19
<i>U. k. praekudarensis</i>	25	72.9±1.15	31	17.1±0.36	27	27.2±0.56	31	14.6±0.27
<i>U. k. kudarensis</i>	78	73.4±0.43	83	17.5±0.17	78	27.7±0.27	87	15.0±0.15
<i>U. rossicus</i>	17	51.5±0.52	14	11.2±0.29	12	18.5±0.28	14	10.1±0.09
<i>U. s. spelaeus</i>	18	67.9±0.69	18	15.3±0.69	15	23.5±0.54	18	13.6±0.24
<i>U. k. kanivetz</i>	19	68.3±1.07	19	15.9±0.30	17	23.9±0.40	19	13.8±0.26
<i>U. s. eremus</i>	20	69.3±0.93	20	15.2±0.38	20	25.2±0.50	20	13.4±0.33
<i>U. s. ladinicus</i>	11	65.8±0.99	11	15.1±0.36	11	24.1±0.55	11	13.6±0.36
<i>U. k. ingressus</i>	38	70.4±0.68	10	16.4±0.37	10	25.4±0.55	39	14.0±0.22
<i>U. arctos</i>	23	75.8±1.88	23	13.5±0.56	19	23.5±0.81	23	11.6±0.43
			Bd		Dd			
			N	M±m	N	M±m		
<i>U. etruscus</i>			1	17.1	1	12.1		
<i>U. deningeri</i>			34	19.2±0.22	32	15.5±0.19		
<i>U. k. praekudarensis</i>			29	22.1±0.38	25	17.5±0.34		
<i>U. k. kudarensis</i>			82	22.8±0.21	67	17.5±0.13		
<i>U. rossicus</i>			17	15.3±0.17	14	12.2±0.10		
<i>U. s. spelaeus</i>			18	19.9±0.35	9	16.4±0.34		
<i>U. k. kanivetz</i>			19	20.3±0.34	12	15.6±0.39		
<i>U. s. eremus</i>			20	20.6±0.39	20	16.6±0.26		
<i>U. s. ladinicus</i>			11	20.2±0.48	10	15.8±0.49		
<i>U. k. ingressus</i>			38	20.4±0.30	26	16.8±0.24		
<i>U. arctos</i>			23	17.8±0.53	20	15.1±0.46		

\* - female proposed

**Sexual dimorphism**Table S9. Sexual size dimorphism (SSD and ASSD) of mtt II in the different forms of cave bears and brown bear ; *p* based on Mann-Whitney U Test; *v*, % - relative variance associated with SSD.

	Measures						ASSD
	GL	Bp	Dp	SD	Bd	Dd	
	<i>U. deningeri</i>						
Males	66.9±0.48	15.4±0.17	23.9±0.25	13.0±0.16	19.6±0.17	15.8±0.16	
Females	59.3±1.02	13.4±0.57	21.8±0.55	11.9±0.72	17.4±0.52	14.1±0.38	
SSD	6.0±0.89	6.8±2.08	4.6±1.32		6.0±1.48	5.6±1.38	5.6
<i>v</i> , %	( <i>p</i> <0.001)	( <i>p</i> <0.001)	( <i>p</i> =0.003)	n.s.	( <i>p</i> <0.001)	( <i>p</i> <0.001)	
	81.1	61.9	55.6	30.7	72.2	65.6	
	<i>U. rossicus</i>						
Males	52.6±0.41	11.5±0.35	18.8±0.20	10.2±0.11	15.4±0.24	12.1±0.15	
Females	48.9±0.38	10.4±0.23	17.4±0.70	10.0±0.18	15.2±0.09	12.2±0.05	

	Measures						ASSD
	GL	Bp	Dp	SD	Bd	Dd	
SSD	3.6±0.55 (p=0.002)	n.s.	n.s.	n.s.	n.s.	n.s.	2.4
v, %	79.4	-	-	-	-	-	
<i>U. k. praekudarensis</i>							
Males	76.1±0.67	18.0±0.22	28.5±0.29	15.2±0.24	23.1±0.19	18.4±0.19	
Females	64.7±0.53	14.5±0.61	22.7±0.91	12.6±0.16	18.9±0.41	15.2±0.30	
SSD	8.1±0.61 (p<0.001)	10.8±2.02 (p<0.001)	11.3±1.88 (p<0.001)	9.2±1.04 (p<0.001)	10.1±1.09 (p<0.001)	9.8±1.05 (p<0.001)	9.9
v, %	91.6	78.1	92.8	75.2	90.4	89.0	
<i>U. k. kudarensis</i>							
Males	75.6±0.31	17.9±0.18	28.7±0.27	15.5±0.18	23.6±0.23	17.9±0.13	
Females	69.4±0.50	16.7±0.27	26.2±0.41	14.3±0.23	21.5±0.31	16.7±0.16	
SSD	4.3±0.41 (p<0.001)	3.5±0.97 (p=0.004)	4.6±0.89 (p<0.001)	4.0±0.98 (p<0.001)	4.5±0.86 (p<0.001)	3.6±0.61 (p<0.001)	4.1
v, %	77.3	18.5	50.3	14.2	25.8	47.6	
<i>U. s. spelaeus</i>							
Males	70.6±0.55	16.1±0.40	25.0±0.74	14.2±0.39	20.8±0.61	17.4±0.28	
Females	65.7±0.51	14.8±0.18	22.1±0.31	13.2±0.22	19.2±0.24	15.6±0.16	
SSD	3.6±0.55 (p<0.001)	4.3±1.44 (p=0.003)	6.2±1.70 (p=0.006)	3.6±1.63 (p=0.03)	4.1±1.63 (p=0.006)	5.4±0.99 (p=0.02)	4.5
v, %	68.9	29.7	79.7	39.2	40.5	87.8	
<i>U. s. ladinicus</i>							
Males	68.5±0.98	16.2±0.25	25.7±0.65	14.4±0.47	21.3±0.68	16.9±1.03	
Females	63.5±0.86	14.2±0.23	22.8±0.24	12.9±0.33	19.3±0.40	15.1±0.15	
SSD	3.8±0.99 (p=0.004)	6.8±1.13 (p=0.004)	6.0±1.43 (p=0.008)	5.6±2.10 (p=0.03)	5.1±1.94 (p=0.02)	5.7±3.26 (p=0.02)	5.5
v, %	67.6	85.7	74.4	46.6	58.0	44.0	
<i>U. s. eremus</i>							
Males	74.2±0.56	17.0±0.50	27.5±0.70	15.0±0.41	22.7±0.26	17.8±0.23	
Females	66.7±0.59	14.2±0.23	24.0±0.34	12.6±0.23	19.5±0.23	15.9±0.22	
SSD	5.3±0.58 (p<0.001)	8.9±1.77 (p<0.001)	6.8±1.51 (p=0.002)	8.6±1.71 (p<0.001)	7.5±0.86 (p<0.001)	5.6±0.95 (p<0.001)	7.13
v, %	88.1	78.5	73.5	76.2	87.4	75.5	
<i>U. k. ingressus</i>							
Males	75.2±0.51	17.5±0.40	27.2±0.55	15.5±0.30	22.5±0.34	17.8±0.16	
Females	68.0±0.51	15.7±0.28	24.2±0.29	13.3±0.16	19.3±0.18	15.9±0.23	
SSD	5.1±0.50 (p<0.001)	5.5±1.48 (p=0.009)	5.8±1.22 (p=0.009)	7.7±1.18 (p=0.009)	7.6±0.92 (p<0.001)	5.7±0.82 (p=0.009)	6.2
v, %	81.7	66.9	81.9	91.5	95.9	94.5	
<i>U. kanivetz</i>							
Males	73.7±1.59	17.1±0.26	25.0±0.30	14.7±0.39	21.9±0.21	16.9±0.81	
Females	65.9±0.65	15.3±0.31	23.5±0.50	13.4±0.27	19.6±0.32	15.0±0.24	
SSD	5.6±1.23 (p<0.001)	5.6±1.23 (p=0.002)	n.s.	4.5±1.69 (p=0.04)	5.7±0.92 (p=0.04)	n.s.	5.1
v, %	88.0	74.7	-	28.6	84.2	-	
<i>U. arctos</i>							
Males	80.3±2.18	15.1±0.61	26.1±0.78	12.8±0.50	19.4±0.59	16.5±0.47	
Females	68.9±1.85	11.5±0.52	20.7±0.70	10.0±0.31	15.7±0.38	13.5±0.37	
SSD	7.6±1.82 (p=)	13.6±3.05 (p=)	11.4±2.25 (p=)	12.5±2.59 (p=)	10.3±2.01 (p=)	10.2±2.00 (p=)	10.9

v, %	Measures						ASSD
	GL	Bp	Dp	SD	Bd	Dd	
	48.4	78.1	72.4	75.2	76.1	68.1	

### Univariate statistic

Table S10. Kruskal-Wallis test  $z'$  values (males - above diagonal and females – under diagonal) for measures of mtc II. The statistical significance values, according to 2-tailed  $p$  values, have been underlined.

Taxa	1	2	3	4	5	6	7	8	9	10
	GL									
<i>U. deningeri</i>	1	1.52	<u>5.81</u>	<u>6.98</u>	1.02	<u>4.60</u>	2.39	2.85	0.34	<u>6.46</u>
<i>U. rossicus</i>	2	0.35	<u>6.07</u>	<u>6.69</u>	2.04	<u>5.13</u>	3.19	<u>3.62</u>	1.29	<u>6.69</u>
<i>U. k. praekudarensis</i>	3	1.36	1.66	0.41	3.14	0.57	1.42	1.21	3.12	1.14
<i>U. k. kudarensis</i>	4	<u>4.99</u>	<u>5.06</u>	<u>3.51</u>	3.21	0.30	1.29	1.06	3.12	1.69
<i>U. s. spelaeus</i>	5	2.00	2.27	0.56	<u>3.29</u>	2.51	1.23	1.53	0.43	<u>3.89</u>
<i>U. k. ingressus</i>	6	<u>3.96</u>	<u>4.10</u>	2.43	1.62	2.04	0.94	0.71	2.60	1.58
<i>U. k. kanivetz</i>	7	2.33	2.59	0.83	3.26	0.28	1.90	0.23	1.50	2.20
<i>U. s. eremus</i>	8	2.82	3.04	1.34	2.55	0.85	1.20	0.61	1.77	2.04
<i>U. s. ladinicus</i>	9	0.86	1.17	0.47	<u>3.88</u>	1.04	2.86	1.32	1.81	<u>3.79</u>
<i>U. arctos</i>	10	<u>3.73</u>	<u>3.90</u>	2.37	0.86	2.00	0.35	1.85	1.28	2.77
	Bp									
<i>U. deningeri</i>	1	1.99	<u>5.79</u>	<u>6.54</u>	0.81	2.52	2.46	2.51	0.89	0.51
<i>U. rossicus</i>	2	1.29	<u>6.20</u>	<u>6.50</u>	2.23	<u>3.51</u>	<u>3.55</u>	<u>3.63</u>	2.12	2.14
<i>U. k. praekudarensis</i>	3	0.97	2.21	0.41	3.15	0.50	1.12	1.29	2.40	<u>4.17</u>
<i>U. k. kudarensis</i>	4	<u>3.79</u>	<u>4.74</u>	2.93	3.13	0.32	0.95	1.13	2.31	<u>4.34</u>
<i>U. s. spelaeus</i>	5	1.40	2.63	0.42	2.65	1.67	1.44	1.42	0.19	0.35
<i>U. k. ingressus</i>	6	2.27	<u>3.32</u>	1.46	0.84	1.14	0.38	0.46	1.36	2.06
<i>U. k. kanivetz</i>	7	2.02	3.19	1.05	2.10	0.65	0.64	0.08	1.11	1.89
<i>U. s. eremus</i>	8	0.73	2.08	0.37	<u>4.02</u>	0.86	1.93	1.62	1.07	1.90
<i>U. s. ladinicus</i>	9	0.41	1.66	0.53	3.25	0.94	1.86	1.53	0.25	0.50
<i>U. arctos</i>	10	1.07	0.47	2.27	<u>6.16</u>	2.85	<u>3.61</u>	<u>3.68</u>	2.17	1.53
	Dp									
<i>U. deningeri</i>	1	1.70	<u>6.03</u>	<u>7.29</u>	0.92	2.08	0.67	3.09	1.12	2.08
<i>U. rossicus</i>	2	1.07	<u>5.96</u>	<u>6.50</u>	2.05	2.93	1.74	<u>3.86</u>	2.13	3.06
<i>U. k. praekudarensis</i>	3	0.85	1.77	0.05	3.08	1.13	2.82	<u>0.98</u>	2.39	2.52
<i>U. k. kudarensis</i>	4	<u>4.14</u>	<u>4.32</u>	3.04	<u>3.28</u>	1.16	2.96	1.02	2.50	2.74
<i>U. s. spelaeus</i>	5	0.19	1.27	0.72	<u>4.40</u>	1.16	0.10	1.71	0.27	0.76
<i>U. k. ingressus</i>	6	1.97	2.69	1.12	1.59	1.92	1.17	0.30	0.85	0.59
<i>U. k. kanivetz</i>	7	1.58	2.40	0.59	3.12	1.50	0.71	1.67	0.34	0.80
<i>U. s. eremus</i>	8	2.12	2.82	1.12	2.43	2.10	0.19	0.65	1.30	1.09
<i>U. s. ladinicus</i>	9	0.81	1.74	0.05	3.10	0.68	1.17	0.64	1.18	0.40
<i>U. arctos</i>	10	0.40	0.82	1.34	<u>5.44</u>	0.65	2.57	2.27	2.91	1.29
	SD									
<i>U. deningeri</i>	1	1.86	<u>4.89</u>	<u>6.78</u>	1.70	<u>4.81</u>	2.33	2.92	1.77	0.29
<i>U. rossicus</i>	2	1.20	<u>5.40</u>	<u>6.52</u>	2.87	<u>5.43</u>	<u>3.34</u>	<u>3.88</u>	2.81	1.85
<i>U. k. praekudarensis</i>	3	0.39	1.58	0.89	1.64	0.74	0.67	0.28	1.00	<u>3.64</u>
<i>U. k. kudarensis</i>	4	<u>3.55</u>	<u>4.44</u>	<u>3.26</u>	2.34	0.11	1.22	0.84	1.52	<u>4.75</u>
<i>U. s. spelaeus</i>	5	1.36	2.49	0.98	2.43	2.06	0.67	1.06	0.31	1.30
<i>U. k. ingressus</i>	6	1.81	2.97	1.41	2.89	0.33	1.14	0.80	1.42	<u>3.84</u>
<i>U. k. kanivetz</i>	7	1.92	3.00	1.55	1.92	0.58	0.37	0.34	0.31	1.92
<i>U. s. eremus</i>	8	0.47	1.76	0.03	<u>4.11</u>	1.11	1.73	1.82	0.64	2.42

Taxa		1	2	3	4	5	6	7	8	9	10
<i>U. s. ladinicus</i>	9	0.87	1.97	0.51	2.42	0.38	0.70	0.90	0.55		1.44
<i>U. arctos</i>	10	1.56	0.05	2.07	<u>6.62</u>	<u>3.36</u>	<u>4.37</u>	<u>4.16</u>	2.47	2.53	
		Bd									
<i>U. deningeri</i>	1		1.82	<u>5.70</u>	<u>7.46</u>	1.25	<u>3.75</u>	2.02	3.25	1.54	0.24
<i>U. rossicus</i>	2	0.91		<u>6.28</u>	<u>7.43</u>	2.48	<u>4.71</u>	3.08	<u>4.21</u>	2.59	1.77
<i>U. k. praekudarensis</i>	3	1.19	2.07		0.49	2.72	1.04	1.55	0.58	1.77	<u>4.41</u>
<i>U. k. kudarensis</i>	4	<u>4.55</u>	<u>5.36</u>	<u>3.28</u>		<u>3.29</u>	1.58	1.95	0.93	2.14	<u>5.38</u>
<i>U. s. spelaeus</i>	5	1.65	2.57	0.39	3.24		1.69	0.76	1.69	0.43	0.93
<i>U. k. ingressus</i>	6	2.08	3.06	0.67	<u>4.02</u>	0.25		0.71	0.24	0.97	3.00
<i>U. k. kanivetz</i>	7	2.41	<u>3.31</u>	1.13	2.54	0.80	0.71		0.83	0.27	1.68
<i>U. s. eremus</i>	8	2.22	3.13	0.93	2.83	0.57	0.43	0.25		1.07	2.76
<i>U. s. ladinicus</i>	9	1.59	2.43	0.47	2.49	0.13	0.06	0.55	0.35		1.27
<i>U. arctos</i>	10	0.86	0.20	2.24	<u>6.79</u>	2.90	<u>3.72</u>	<u>3.89</u>	<u>3.66</u>	2.64	
		Dd									
<i>U. deningeri</i>	1		1.77	<u>6.17</u>	<u>5.88</u>	1.76	<u>3.90</u>	1.46	3.15	1.19	1.42
<i>U. rossicus</i>	2	0.91		<u>6.47</u>	<u>6.04</u>	2.71	<u>4.71</u>	2.44	<u>4.06</u>	2.19	2.68
<i>U. k. praekudarensis</i>	3	1.14	1.95		1.54	1.72	1.43	2.00	1.24	2.27	<u>3.61</u>
<i>U. k. kudarensis</i>	4	<u>4.40</u>	<u>4.81</u>	3.20		0.99	0.31	1.29	0.29	1.57	2.81
<i>U. s. spelaeus</i>	5	1.78	2.49	0.76	1.89		0.72	0.22	0.63	0.43	0.74
<i>U. k. ingressus</i>	6	2.72	<u>3.38</u>	1.50	2.03	0.47		1.00	0.04	1.25	2.03
<i>U. k. kanivetz</i>	7	1.07	1.91	0.11	<u>3.50</u>	0.88	1.69		0.89	0.21	0.47
<i>U. s. eremus</i>	8	2.84	<u>3.48</u>	1.64	1.77	0.61	0.19	1.83		1.12	1.71
<i>U. s. ladinicus</i>	9	0.95	1.76	0.15	3.20	0.88	1.59	0.05	1.72		0.22
<i>U. arctos</i>	10	0.46	0.58	1.74	<u>5.76</u>	2.37	<u>3.67</u>	1.69	<u>3.79</u>	1.50	

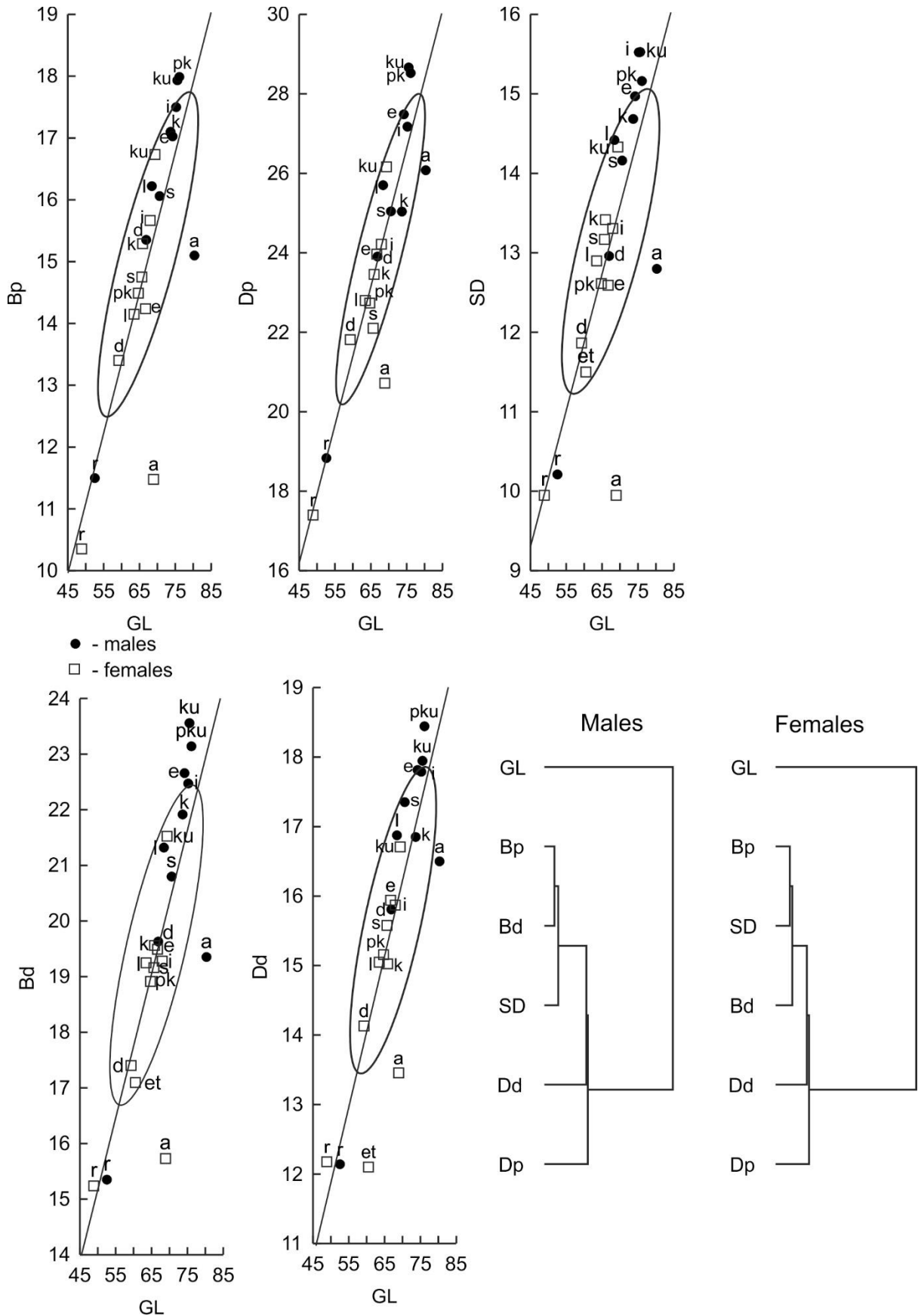

Fig. S6. The scatterplots of measures (GL – Dd) of mtt II and their UPMGA classification, and single linkage dendrograms of measurements based on the correlation metric. et – *U. etruscus*, a – *U. arctos*, r – *U. rossicus*, d – *U. deningeri*, pk – *U. k. praekudarensis*, ku – *U. k. kudarensis*, s – *U. s. spelaeus*, k, U – *U. k. kanivetz*, U, k, EE – *Ursus. kanivetz*, EE, e – *U. s. eremus*, l – *U. s. ladinicus*.

Table S11. Statistical parameters of measures of mtt II among different bears and sexes: m – males, f – females.

Taxa	Sex	GL - N	GL	GL Std.Dev.	Bp - N	Bp	Bp Std.Dev.	Dp - N	Dp	Dp Std.Dev.	SD - N	SD	SD Std.Dev.	Bd - N	Bd	Bd Std.Dev.	Dd - N	Dd	Dd Std.Dev.
<i>U. etruscus</i>	f	1	60.5								1	11.5		1	17.1		1	12.1	
<i>U. rossicus</i>	f	5	48.9	0.85	4	10.4	0.47	3	17.4	1.22	4	10.0	0.37	5	15.2	0.21	4	12.2	0.10
	m	12	52.6	1.43	10	11.5	1.12	9	18.8	0.59	10	10.2	0.34	12	15.4	0.84	10	12.1	0.46
<i>U. deningeri</i>	f	6	59.3	2.49	6	13.4	1.40	6	21.8	1.34	6	11.9	1.77	6	17.4	1.28	6	14.1	0.93
	m	29	66.9	2.59	29	15.4	0.92	29	23.9	1.34	29	13.0	0.87	28	19.6	0.87	26	15.8	0.82
<i>U. k. praekudarensis</i>	f	7	64.7	1.40	8	14.5	1.73	6	22.7	2.23	7	12.6	0.43	7	18.9	1.09	7	15.2	0.78
	m	18	76.1	2.83	23	18.0	1.07	21	28.5	1.35	24	15.2	1.16	22	23.1	0.91	18	18.4	0.81
<i>U. k. kudarensis</i>	f	28	69.4	2.64	31	16.7	1.52	30	26.2	2.23	35	14.3	1.37	30	21.5	1.69	24	16.7	0.81
	m	50	75.6	2.19	52	17.9	1.41	48	28.7	1.86	52	15.5	1.28	52	23.6	1.67	43	17.9	0.87
<i>U. s. spelaeus</i>	f	10	65.7	1.60	10	14.8	0.58	8	22.1	0.88	10	13.2	0.70	10	19.2	0.75	5	15.6	0.36
	m	8	70.6	1.55	8	16.1	1.14	7	25.0	1.95	8	14.2	1.09	8	20.8	1.71	4	17.4	0.57
<i>U. k. kanivetz</i> , EE	f	25	68.0	2.54	6	15.7	0.68	6	24.2	0.72	26	13.3	0.83	25	19.3	0.91	14	15.9	0.85
	m	13	75.2	1.85	4	17.5	0.80	4	27.2	1.11	13	15.5	1.08	13	22.5	1.22	12	17.8	0.54
<i>U. k. kanivetz</i> , U	f	13	65.9	2.36	13	15.3	1.10	12	23.5	1.73	13	13.4	0.98	13	19.6	1.16	8	15.0	0.68
	m	6	73.7	3.89	6	17.1	0.63	5	25.0	0.67	6	14.7	0.95	6	21.9	0.50	4	16.9	1.63
<i>U. s. eremus</i>	f	13	66.7	2.13	13	14.2	0.82	13	24.0	1.23	13	12.6	0.84	13	19.5	0.91	13	15.9	0.80
	m	7	74.2	1.49	7	17.0	1.33	7	27.5	1.84	7	15.0	1.08	7	22.7	0.68	7	17.8	0.60
<i>U. s. ladinicus</i>	f	6	63.5	2.10	6	14.2	0.58	6	22.8	0.60	6	12.9	0.81	6	19.3	0.97	6	15.1	0.37
	m	5	68.5	2.19	5	16.2	0.56	5	25.7	1.45	5	14.4	1.04	5	21.3	1.52	4	16.9	2.06
<i>U. arctos</i>	f	10	68.9	5.84	10	11.5	1.65	9	20.7	2.10	10	10.0	0.97	10	15.7	1.19	9	13.5	1.11
	m	13	80.3	7.85	13	15.1	2.20	10	26.1	2.45	13	12.8	1.79	13	19.4	2.13	11	16.5	1.55

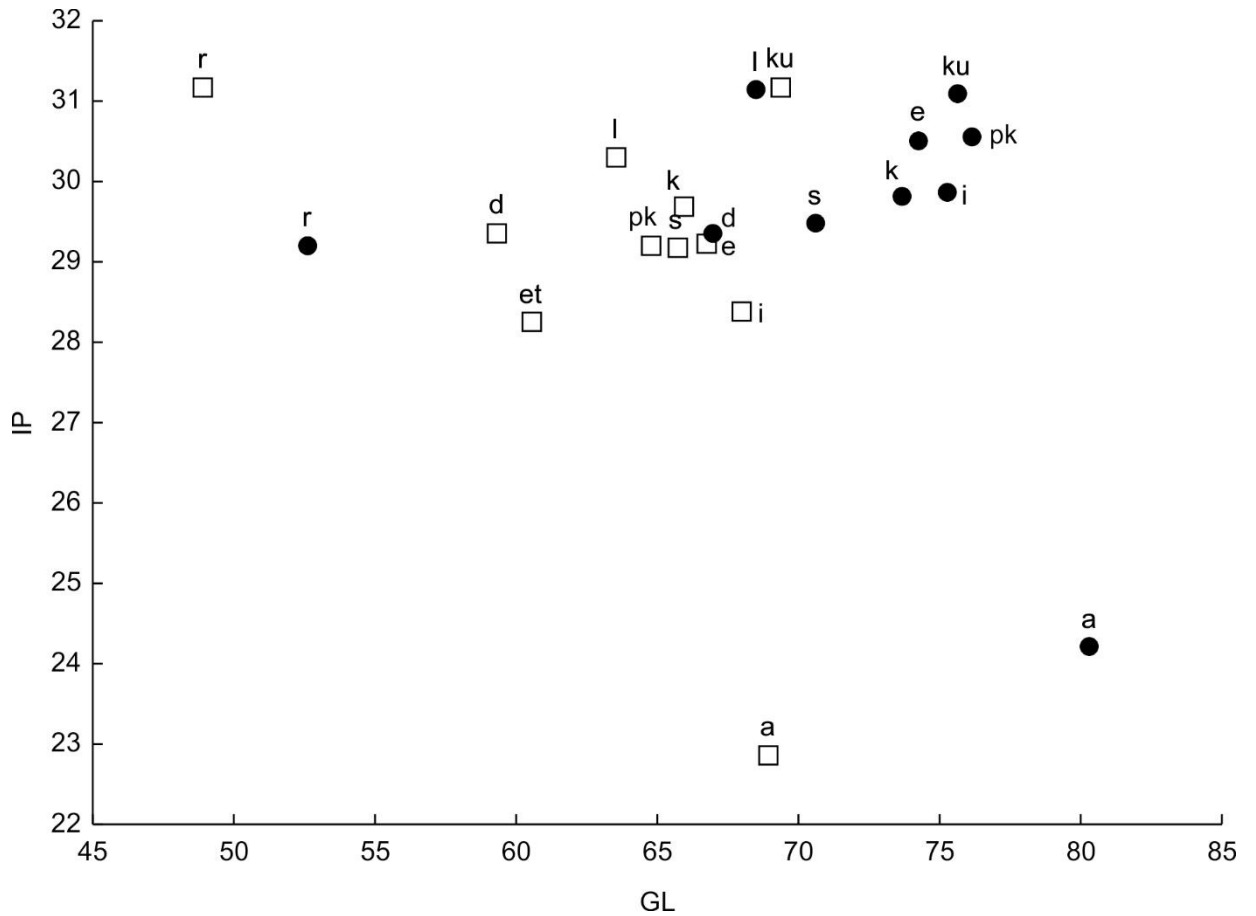

Fig. S7. The scatterplot of Index plumpness (ip) and GL of mtt II: et – *U. etruscus*, a – *U. arctos*, r – *U. rossicus*, d – *U. deningeri*, pk – *U. k. praekudarensis*, ku – *U. k. kudarensis*, s – *U. s. spelaeus*, k – *U. k. kanivetz*, i – *U. k. ingressus*, e – *U. s. eremus*, l – *U. s. ladinicus*. Point – males, square – females.

**Multivariate analysis**

Table S12. Description of the modeled morphological spaces for cave bears and brown bear mtt II. Correlation coefficients among the measures and dimensions of two morphospace models (MDS axes: E1–E2, K1–K2);  $r^2$  – coefficients of determination in the linear multiple regression models.

Measures	Morphospaces with <i>U. arctos</i>				$r^2$	Morphospaces without <i>U. arctos</i>				$r^2$
	“Size”		“Shape”			“Size”		“Shape”		
	morphospace		morphospace			morphospace		morphospace		
	E1	E2	K1	K2		E1	E2	K1	K2	
GL	0.83	0.47	0.30	0.28	0.94	0.94	-0.25	0.15	0.43	0.92
Bp	0.95	-0.01	-0.12	0.34	0.94	0.94	-0.05	0.11	0.15	0.95
Dp	0.96	0.21	0.15	0.53	0.94	0.95	-0.19	-0.04	0.47	0.96
SD	0.93	-0.18	-0.31	0.45	0.95	0.93	0.16	0.40	0.34	0.96
Bd	0.96	-0.04	-0.09	0.60	0.96	0.96	-0.00	0.15	0.39	0.94
Dd	0.95	0.22	0.05	0.49	0.92	0.95	-0.27	0.15	0.29	0.94
ip	0.46	-0.35	-0.30	0.59		0.43	0.44	0.13	0.14	
Relative variance (%) of dimensions associated with taxonomical composition										
	61.2	40.9	31.4	39.0		65.7	5.4	12.2	21.1	



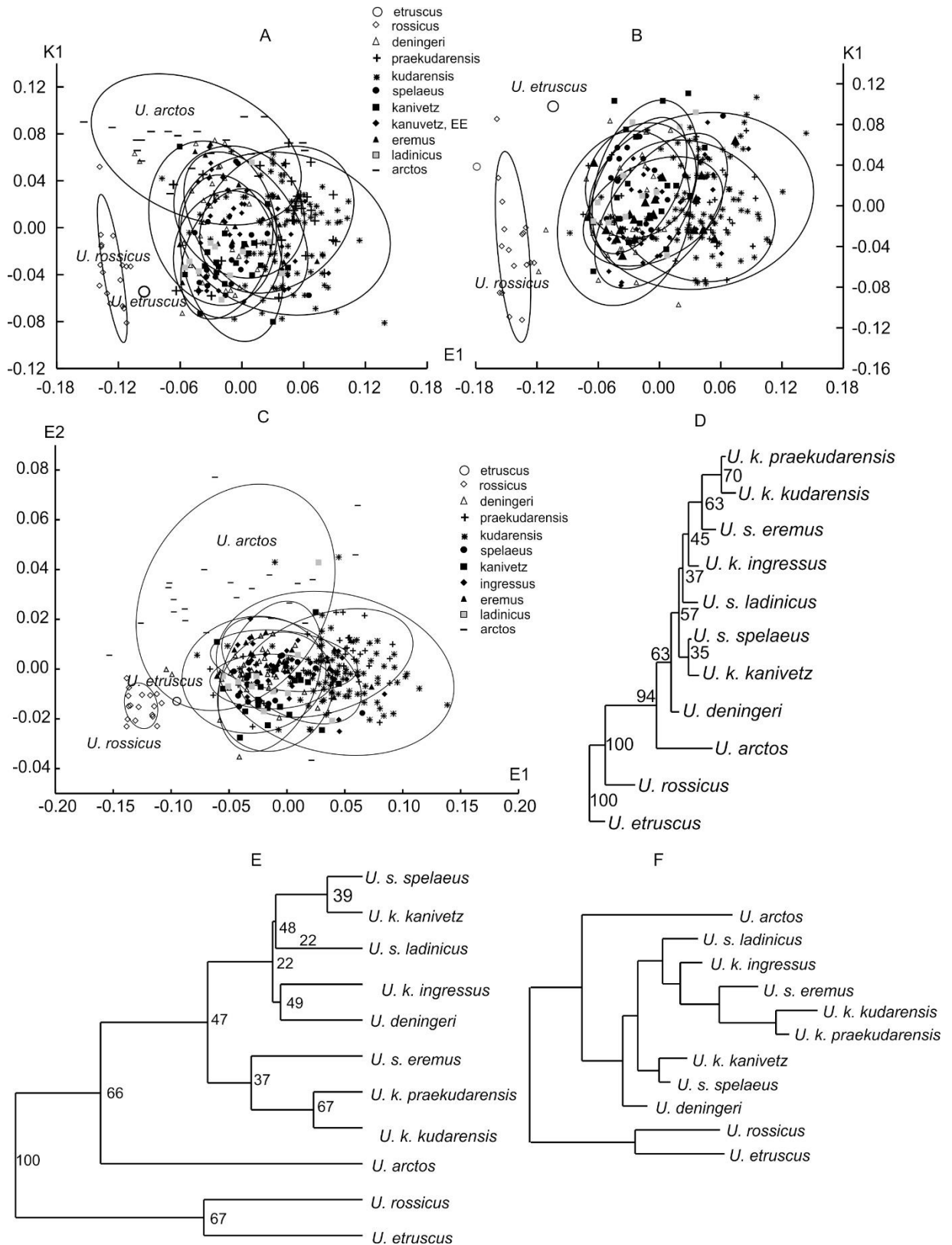

Fig. S8. Scatterplot of the first dimensions of “size” (E1) and “shape” (K1) morphospaces reproduced variation of mtt II in males and females: A, C – models with *U. arctos*; B – model without *U. arctos*; C – “size” morphospace; D – NJ tree; E – UGMA dendrogram (cophenetic correlation – 0.92; F – Sattath-Tversky (Sattath, Tversky, 1977) additive tree. All classifications based on the coordinates of samples’ centroids in the “size” (E1, E2) and “shape” (K1, K2) morphospaces (numbers near the nodes - bootstrap (1000 repeats) supports in %). Ellipses’ horizontal and vertical projection onto the E1 (E2) and K1 axes are equal to the “sample mean” (centroid)  $\pm$  “sample range”  $\times 0.95$ .

**Males**

Table S13. Description of the modeled morphological spaces for males of cave bears and brown bear mtt II. Correlation coefficients among the measures and dimensions of two morphospace models (MDS axes: E1–E2, K1–K2);  $r^2$  – coefficients of determination in the linear multiple regression models.

Measures	Morphospaces with <i>U. arctos</i>				Morphospaces without <i>U. arctos</i>					
	“Size” morphospace		“Shape” morphospace		“Size” morphospace		“Shape” morphospace		$r^2$	$r^2$
	E1	E2	K1	K2	E1	E2	K1	K2		
GL	0.85	0.49	0.09	0.42	0.85	0.94	0.23	0.08	0.61	0.94
Bp	0.94	0.08	-0.31	0.31	0.92	0.94	0.04	0.04	0.30	0.94
Dp	0.96	0.28	-0.13	0.62	0.95	0.96	0.16	-0.09	0.57	0.94
SD	0.93	-0.14	-0.54	0.36	0.95	0.94	-0.19	0.35	0.44	0.96
Bd	0.95	0.03	-0.30	0.54	0.93	0.96	-0.04	0.06	0.52	0.94
Dd	0.94	0.20	-0.22	0.43	0.89	0.95	0.10	0.07	0.43	0.91
ip	0.49	-0.36	-0.44	0.38		0.46	-0.48	0.15	0.07	
Relative variance (%) of dimensions associated with taxonomical composition										
	83.2	38.9	29.7	35.0		88.2	8.1	6.9	42.3	

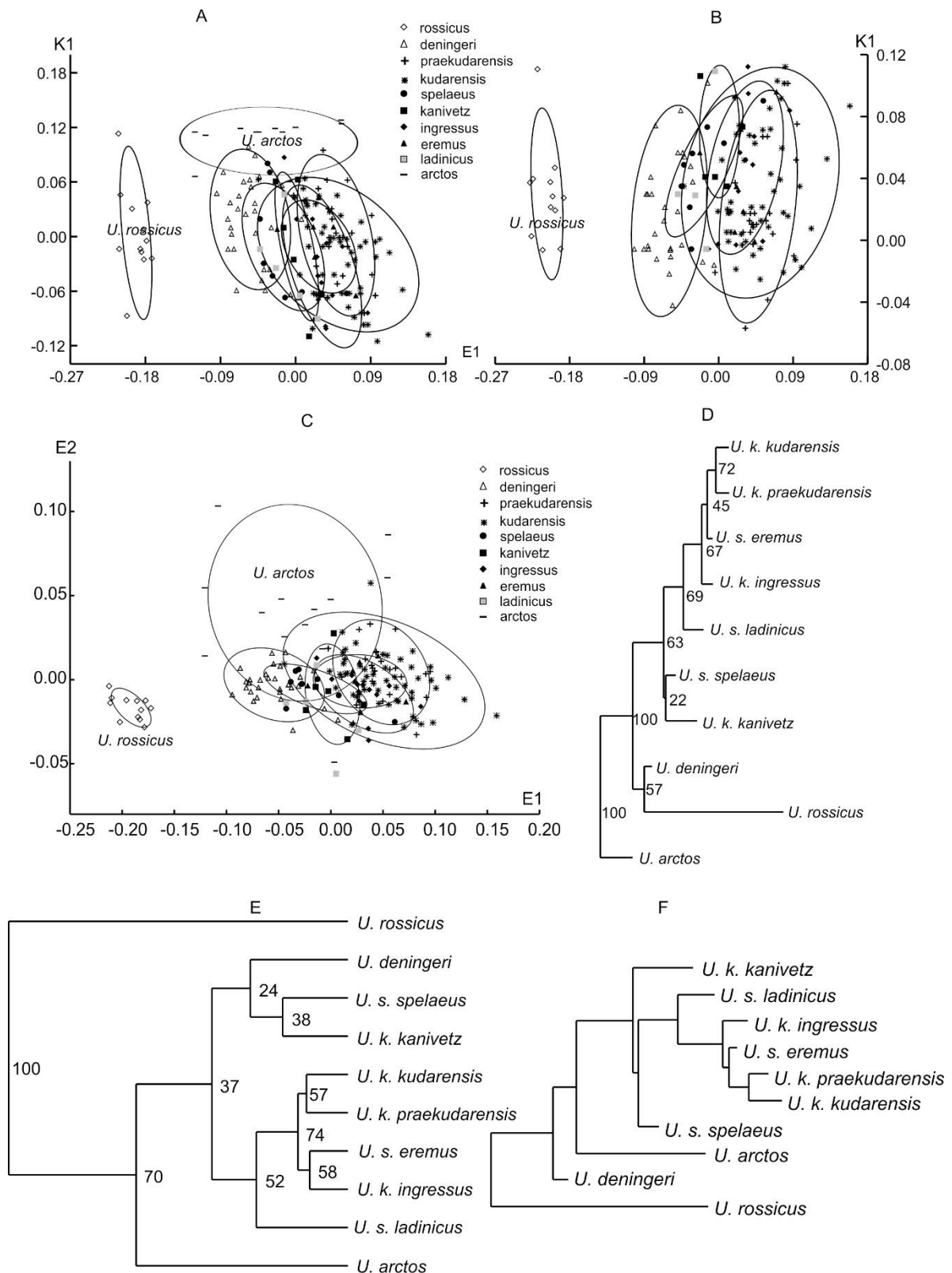

Fig. S9. Scatterplot of the first dimensions of "size" (E1) and "shape" (K1) morphospaces reproduced variation of mtt II in males: A, C – models with *U. arctos*; B – model without *U. arctos*; C – "size" morphospace; D – NJ tree; E – UGMA dendrogram (cophenetic correlation – 0.90); F – Sattath-Tversky (Sattath, Tversky, 1977) additive tree. All classifications based on the coordinates of samples' centroids in the "size" (E1, E2) and "shape" (K1, K2) morphospaces (numbers near the nodes - bootstrap (1000 repeats) supports in %). Ellipses' horizontal and vertical projection onto the E1 (E2) and K1 axes are equal to the "sample mean" (centroid)  $\pm$  "sample range"  $\times 0.95$ .

## Females

Table S14. Description of the modeled morphological spaces for females of cave bears and brown bear mtt II. Correlation coefficients among the measures and dimensions of two morphospace models (MDS axes: E1–E2, K1–K2);  $r^2$  – coefficients of determination in the linear multiple regression models.

Measures	Morphospaces with <i>U. arctos</i>					Morphospaces without <i>U. arctos</i>				
	“Size”		“Shape”		$r^2$	“Size”		“Shape”		$r^2$
	morphospace		morphospace			morphospace		morphospace		
	E1	E2	K1	K2	E1	E2	K1	K2		
GL	0.67	0.60	0.15	0.31	0.83	0.91	-0.10	0.05	0.31	0.82
BP	0.96	-0.15	-0.43	0.35	0.91	0.94	0.08	0.35	0.16	0.89
BD	0.92	0.10	-0.20	0.31	0.89	0.91	-0.14	0.07	0.07	0.89
SD	0.92	-0.35	-0.61	0.12	0.94	0.89	0.34	0.55	0.16	0.92
DP	0.96	-0.18	-0.50	0.40	0.94	0.95	-0.04	0.37	0.18	0.90
DD	0.94	0.03	-0.25	0.56	0.94	0.92	-0.30	0.08	0.49	0.96
ip	0.33	-0.41	-0.69	0.27		0.33	0.13	0.47	-0.09	
Relative variance (%) of dimensions associated with taxonomical composition										
	73.3	57.1	46.0	15.6		70.7	10.1	24.4	19.9	

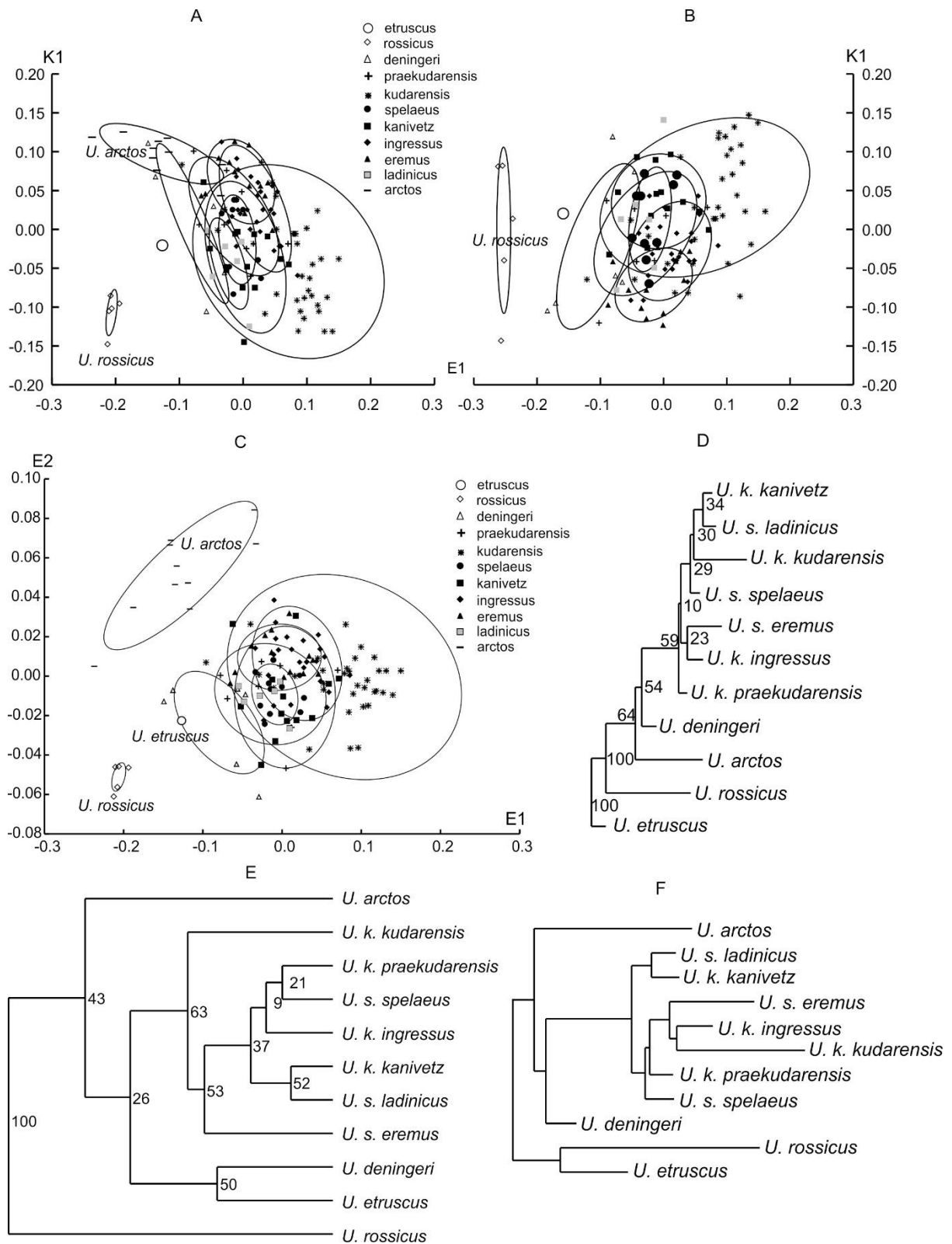

Fig. S10. Scatterplot of the first dimensions of "size" (E1) and "shape" (K1) morphospaces reproduced variation of mtt II in females: A, C – models with *U. arctos*; B – model without *U. arctos*; C – "size" morphospace; D – NJ tree; E – UGMA dendrogram (cophenetic correlation – 0.86); F – Sattath-Tversky (Sattath, Tversky, 1977) additive tree. All classifications based on the coordinates of samples' centroids in the "size" (E1, E2) and "shape" (K1, K2) morphospaces (numbers near the nodes - bootstrap (1000 repeats) supports in %). Ellipses' horizontal and vertical projection onto the E1 (E2) and K1 axes are equal to the "sample mean" (centroid) ± "sample range" x 0.95.

**METATARSAL BONE III (MTT III)****Males and females**

Table S15. Sample numbers (N), means (M), and standard errors (m) of the variables of mtt III among different forms of bears

Form	GL		Bp		Dp		SD	
	N	M±m	N	M±m	N	M±m	N	M±m
<i>U. etruscus</i>	1	78.0					1	12.5
<i>U. deningeri</i>	38	75.4±0.92	38	18.7±0.34	37	28.6±0.45	38	14.1±0.25
<i>U. k. praekudarensis</i>	19	81.8±1.22	24	19.4±0.32	22	31.3±0.45	23	15.2±0.28
<i>U. k. kudarensis</i>	68	83.4±0.49	75	19.8±0.18	70	31.0±0.24	76	16.2±0.14
<i>U. rossicus</i>	17	58.8±0.58	17	14.2±0.32	17	23.3±0.43	17	11.5±0.14
<i>U. s. spelaeus</i>	18	78.8±1.19	18	19.1±0.44	15	29.6±0.72	18	15.9±0.33
<i>U. k. kanivetz</i>	22	78.4±1.04	24	18.9±0.46	21	29.8±0.69	24	15.7±0.28
<i>U. s. eremus</i>	20	78.1±1.29	20	19.3±0.46	20	30.0±0.54	20	14.8±0.33
<i>U. s. ladinicus</i>	14	71.7±0.91	14	17.6±0.51	14	27.9±0.57	14	13.8±0.36
<i>U. k. ingressus</i>	55	80.6±0.63	27	19.4±0.40	25	30.8±0.48	55	16.2±0.22
<i>U. arctos</i>	30	76.9±1.49	30	16.2±0.52	17	25.7±1.10	31	12.0±0.34
			Bd		Dd			
			N	M±m	N	M±m		
<i>U. etruscus</i>			1	18.2	1	14.7		
<i>U. deningeri</i>			38	20.7±0.34	35	16.9±0.27		
<i>U. k. praekudarensis</i>			20	22.5±0.43	17	18.1±0.33		
<i>U. k. kudarensis</i>			69	23.2±0.20	63	18.5±0.13		
<i>U. rossicus</i>			17	16.3±0.17	12	12.7±0.11		
<i>U. s. spelaeus</i>			18	21.8±0.47	11	18.2±0.39		
<i>U. k. kanivetz</i>			21	21.8±0.36	17	17.8±0.30		
<i>U. s. eremus</i>			20	21.7±0.38	20	17.6±0.32		
<i>U. s. ladinicus</i>			14	20.3±0.48	14	16.4±0.26		
<i>U. k. ingressus</i>			55	22.4±0.27	41	18.0±0.24		
<i>U. arctos</i>			31	17.5±0.45	19	15.9±0.55		

**Sexual dimorphism**Table S16. Sexual size dimorphism (SSD and ASSD) of mtt III in the different forms of cave bears and brown bear ; *p* based on Mann-Whitney U Test; *v*, % - relative variance associated with SSD.

	Measures						ASSD
	GL	Bp	Dp	SD	Bd	Dd	
	<i>U. deningeri</i>						
Males	80.5±0.77	20.3±0.43	30.9±0.55	15.1±0.35	22.2±0.50	18.0±0.37	
Females	71.2±0.70	17.5±0.31	26.8±0.35	13.3±0.24	19.5±0.27	16.0±0.23	
SSD	6.1±0.68	7.4±1.41	7.1±1.13	6.4±1.49	6.5±1.36	5.9±1.30	6.6
<i>v</i> , %	( <i>p</i> <0.001) 82.6	( <i>p</i> <0.001) 57.4	( <i>p</i> <0.001) 69.6	( <i>p</i> <0.001) 52.4	( <i>p</i> <0.001) 56.5	( <i>p</i> <0.001) 54.8	
	<i>U. rossicus</i>						
Males	60.3±0.35	14.4±0.50	23.8±0.56	11.3±0.23	16.5±0.22	12.9±0.04	
Females	56.1±0.55	14.0±0.24	22.3±0.49	11.6±0.13	15.9±0.19	12.6±0.21	
SSD	3.6±0.56	n.s.	( <i>p</i> =0.045)	n.s.	n.s.	n.s.	1.7

	Measures						ASSD
	GL	Bp	Dp	SD	Bd	Dd	
	( $p < 0.001$ )						
<i>v</i> , %	81.5	-	-	-	-	-	
	<i>U. k. praekudarensis</i>						
Males	84.0±0.71	20.0±0.21	32.0±0.33	15.7±0.25	23.3±0.38	18.5±0.35	
Females	73.9±1.44	17.0±0.54	28.1±0.84	13.5±0.39	20.2±0.38	16.8±0.42	
SSD	6.4±1.02	8.1±1.56	6.5±1.51	7.4±1.60	7.3±1.24	4.8±1.55	6.8
	( $p < 0.001$ )	( $p < 0.001$ )	( $p = 0.002$ )	( $p < 0.001$ )	( $p < 0.001$ )	( $p = 0.015$ )	
<i>v</i> , %	84.0	81.1	73.2	55.0	82.0	44.6	
	<i>U. k. kudarensis</i>						
Males	86.8±0.41	20.4±1.48	32.0±1.71	16.8±0.20	24.0±0.26	19.0±0.21	
Females	80.3±0.42	19.1±1.47	30.0±1.79	15.6±0.16	22.5±0.24	18.0±0.18	
SSD	3.9±0.35	3.2±0.86	3.2±0.68	3.5±0.80	3.3±0.76	2.7±0.59	2.9
	( $p < 0.001$ )	( $p < 0.001$ )	( $p < 0.001$ )	( $p < 0.001$ )	( $p < 0.001$ )	( $p < 0.001$ )	
<i>v</i> , %	78.3	18.1	33.5	33.8	38.4	36.6	
	<i>U. s. spelaeus</i>						
Males	84.6±1.35	21.2±0.64	32.3±0.77	17.5±0.38	24.0±0.67	19.3±0.45	
Females	75.9±0.79	18.0±0.27	28.2±0.67	15.0±0.20	20.7±0.25	17.2±0.22	
SSD	5.4±0.97	8.3±1.78	6.9±1.68	7.6±1.32	7.5±1.61	5.6±1.37	6.9
	( $p < 0.001$ )	( $p < 0.001$ )	( $p = 0.001$ )	( $p < 0.001$ )	( $p < 0.001$ )	( $p = 0.009$ )	
<i>v</i> , %	78.5	68.2	71.6	89.8	83.6	90.7	
	<i>U. s. ladinicus</i>						
Males	75.8±0.91	18.6±0.68	29.8±0.67	14.9±0.51	21.9±0.50	17.3±0.20	
Females	69.3±0.51	16.9±0.64	26.6±0.43	12.9±0.24	19.1±0.35	15.7±0.18	
SSD	4.0±0.72	n.s.	5.6±1.41	7.0±2.05	7.0±1.49	4.7±0.80	5.5
	( $p < 0.001$ )		( $p = 0.003$ )	( $p = 0.01$ )	( $p = 0.001$ )	( $p = 0.001$ )	
<i>v</i> , %	81.7	-	69.0	62.0	76.8	83.9	
	<i>U. s. eremus</i>						
Males	84.0±1.27	21.5±0.33	32.4±0.58	16.3±0.34	23.4±0.42	19.0±0.33	
Females	74.2±0.76	17.9±0.30	28.4±0.34	13.7±0.17	20.5±0.22	16.6±0.20	
SSD	6.2±0.94	9.1±1.15	6.6±1.11	8.6±1.27	6.4±1.09	6.7±1.10	7.3
	( $p < 0.001$ )	( $p < 0.001$ )	( $p < 0.001$ )	( $p < 0.001$ )	( $p < 0.001$ )	( $p < 0.001$ )	
<i>v</i> , %	83.6	86.2	80.2	85.0	80.8	81.2	
	<i>U. k. ingressus</i>						
Males	85.2±0.55	21.6±0.47	33.5±0.50	17.8±0.22	24.3±0.28	19.3±0.21	
Females	77.2±0.41	18.1±0.22	29.3±0.26	15.0±0.15	21.6±0.16	16.8±0.18	
SSD	4.9±0.43	8.9±1.32	6.7±0.90	8.5±0.81	7.5±0.72	6.8±0.77	7.2
	( $p < 0.001$ )	( $p < 0.001$ )	( $p < 0.001$ )	( $p < 0.001$ )	( $p < 0.001$ )	( $p < 0.001$ )	
<i>v</i> , %	87.4	84.0	87.0	90.1	86.0	73.8	
	<i>U. kanivetz</i>						
Males	84.1±0.67	20.9±0.58	32.1±1.04	16.6±0.44	23.2±0.59	19.2±0.34	
Females	75.1±0.54	17.1±0.33	28.0±0.50	15.0±0.24	21.0±0.27	17.1±0.15	
SSD	5.7±0.55	8.7±1.76	6.8±1.93	5.1±1.58	5.0±1.47	5.9±1.02	6.2
	( $p < 0.001$ )	( $p < 0.001$ )	( $p = 0.009$ )	( $p = 0.003$ )	( $p = 0.006$ )	( $p < 0.001$ )	
<i>v</i> , %	93.4	79.8	69.0	67.6	74.5	84.0	
	<i>U. arctos</i>						
Males	86.3±3.22	19.3±1.33	29.3±1.72	13.8±0.64	20.4±0.71	17.7±0.62	
Females	73.5±0.93	15.1±0.27	23.2±0.75	11.2±0.27	16.4±0.32	14.2±0.45	
SSD	8.0±2.11	12.4±3.96	11.6±3.59	10.1±2.78	10.9±2.12	10.7±2.43	10.6
	( $p < 0.001$ )	( $p < 0.001$ )	( $p = 0.002$ )	( $p < 0.001$ )	( $p < 0.001$ )	( $p < 0.001$ )	

## Univariate analysis

Table S17. Kruskal-Wallis test z' values (males - above diagonal and females – under diagonal) for measures of mtt III. The statistical significance values, according to 2-tailed *p* values, have been underlined.

Taxa		1	2	3	4	5	6	7	8	9	10
		GL									
<i>U. deningeri</i>	1		2.21	1.98	<u>5.10</u>	1.88	3.21	1.84	1.75	1.21	2.68
<i>U. rossicus</i>	2	1.59		<u>3.90</u>	<u>6.83</u>	<u>3.45</u>	<u>5.13</u>	<u>3.55</u>	<u>3.46</u>	0.55	<u>4.32</u>
<i>U. k. praekudarensis</i>	3	1.10	2.13		2.54	0.36	0.92	0.17	0.08	2.65	0.98
<i>U. k. kudarensis</i>	4	<u>7.51</u>	<u>6.35</u>	3.17		1.43	1.85	1.87	1.98	<u>4.73</u>	0.96
<i>U. s. spelaeus</i>	5	2.94	<u>3.61</u>	0.97	2.99		0.29	0.19	0.27	2.54	0.48
<i>U. k. ingressus</i>	6	<u>4.83</u>	<u>4.71</u>	1.68	2.90	0.86		0.57	0.67	<u>3.49</u>	0.31
<i>U. k. kanivetz</i>	7	2.35	3.17	0.50	<u>3.97</u>	0.65	1.70		0.08	2.53	0.72
<i>U. s. eremus</i>	8	1.70	2.71	0.12	<u>4.34</u>	1.10	2.19	0.50		2.45	0.80
<i>U. s. ladinicus</i>	9	0.90	0.67	1.62	<u>6.24</u>	3.16	<u>4.38</u>	2.68	2.17		3.20
<i>U. arctos</i>	10	1.68	2.72	0.07	<u>5.72</u>	1.54	3.05	0.87	0.28	2.15	
		Bp									
<i>U. deningeri</i>	1		<u>3.75</u>	0.43	0.34	1.21	1.88	0.89	1.85	1.82	1.07
<i>U. rossicus</i>	2	2.83		<u>3.47</u>	<u>4.37</u>	<u>4.04</u>	<u>4.97</u>	<u>4.14</u>	<u>4.79</u>	1.37	2.29
<i>U. k. praekudarensis</i>	3	0.55	1.80		0.85	1.53	2.29	1.28	2.22	1.54	0.76
<i>U. k. kudarensis</i>	4	<u>3.63</u>	<u>5.04</u>	2.65		1.08	1.83	0.72	1.78	2.19	1.44
<i>U. s. spelaeus</i>	5	0.96	<u>3.30</u>	1.17	1.93		0.34	0.42	0.40	2.49	1.92
<i>U. k. ingressus</i>	6	1.38	<u>3.66</u>	1.42	1.84	0.27		0.88	0.09	3.13	2.55
<i>U. k. kanivetz</i>	7	0.02	2.72	0.54	3.13	0.86	1.23		0.92	2.36	1.72
<i>U. s. eremus</i>	8	0.81	3.20	1.07	2.09	0.13	0.42	0.73		3.07	2.50
<i>U. s. ladinicus</i>	9	0.41	2.18	0.18	2.97	1.13	1.45	0.40	1.01		0.75
<i>U. arctos</i>	10	<u>3.56</u>	0.65	1.64	<u>7.74</u>	<u>4.00</u>	<u>4.76</u>	3.20	<u>3.85</u>	2.22	
		Dp									
<i>U. deningeri</i>	1		3.04	1.31	1.39	1.25	2.71	1.71	1.46	1.09	0.66
<i>U. rossicus</i>	2	1.85		<u>4.15</u>	<u>4.42</u>	<u>3.43</u>	<u>5.03</u>	<u>4.18</u>	<u>3.90</u>	1.47	1.96
<i>U. k. praekudarensis</i>	3	0.96	2.15		0.10	0.38	1.67	0.65	0.44	2.06	1.68
<i>U. k. kudarensis</i>	4	<u>5.49</u>	<u>5.09</u>	1.87		0.46	1.90	0.79	0.55	2.13	1.74
<i>U. s. spelaeus</i>	5	1.86	2.99	0.32	2.22		0.88	0.14	0.01	1.92	1.60
<i>U. k. ingressus</i>	6	<u>3.55</u>	<u>4.10</u>	1.17	1.10	1.15		0.88	1.02	3.13	2.84
<i>U. k. kanivetz</i>	7	1.46	2.73	0.01	2.94	0.43	1.70		0.16	2.34	2.01
<i>U. s. eremus</i>	8	1.96	3.06	0.32	2.40	0.01	1.23	0.44		2.14	1.81
<i>U. s. ladinicus</i>	9	0.36	1.36	1.10	<u>4.24</u>	1.82	3.07	1.48	1.88		0.40
<i>U. arctos</i>	10	1.97	0.30	2.16	<u>6.34</u>	<u>3.29</u>	<u>4.80</u>	3.00	<u>3.42</u>	1.28	
		SD									
<i>U. deningeri</i>	1		2.22	0.53	3.24	3.19	<u>5.13</u>	2.26	1.59	0.39	0.98
<i>U. rossicus</i>	2	1.66		2.64	<u>4.72</u>	<u>4.51</u>	<u>6.10</u>	<u>3.85</u>	3.24	1.46	1.17
<i>U. k. praekudarensis</i>	3	0.13	1.37		2.68	2.83	<u>4.64</u>	1.83	1.17	0.78	1.43
<i>U. k. kudarensis</i>	4	<u>5.53</u>	<u>5.17</u>	3.03		1.29	2.63	0.12	0.68	2.58	<u>3.64</u>
<i>U. s. spelaeus</i>	5	3.10	<u>3.78</u>	1.99	1.16		0.27	1.19	1.55	2.94	<u>3.64</u>
<i>U. k. ingressus</i>	6	<u>3.87</u>	<u>4.17</u>	2.13	1.74	0.10		1.95	2.34	<u>3.98</u>	<u>5.20</u>
<i>U. k. kanivetz</i>	7	3.16	<u>3.81</u>	1.97	1.33	0.08	0.01		0.47	2.11	2.84
<i>U. s. eremus</i>	8	0.42	1.84	0.17	<u>4.08</u>	2.37	2.76	2.38		1.60	2.23
<i>U. s. ladinicus</i>	9	0.57	0.98	0.53	<u>4.48</u>	2.98	<u>3.35</u>	2.99	0.85		0.42
<i>U. arctos</i>	10	2.50	0.02	1.66	<u>8.46</u>	<u>5.25</u>	<u>6.68</u>	<u>5.41</u>	2.55	1.27	
		Bd									



Taxa		1	2	3	4	5	6	7	8	9	10	
<i>U. deningeri</i>	1		3.23	1.11	2.57	1.48	3.13	1.13	1.02	0.75	1.73	
<i>U. rossicus</i>	2	2.08		<u>4.14</u>	<u>5.79</u>	<u>3.85</u>	<u>6.14</u>	<u>3.73</u>	<u>3.63</u>	1.76	1.19	
<i>U. k. praekudarensis</i>	3	0.62	2.09		1.19	0.64	1.83	0.20	0.10	1.55	2.63	
<i>U. k. kudarensis</i>	4	<u>5.91</u>	<u>5.87</u>	2.76		0.14	0.86	0.72	0.83	2.53	<u>3.94</u>	
<i>U. s. spelaeus</i>	5	1.73	3.18	0.60	2.99		0.65	0.41	0.49	1.83	2.69	
<i>U. k. ingressus</i>	6	3.02	<u>4.07</u>	1.13	3.19	0.65		1.26	1.37	2.96	<u>4.36</u>	
<i>U. k. kanivetz</i>	7	2.42	<u>3.68</u>	1.04	2.38	0.56	0.01		0.09	1.55	2.47	
<i>U. s. eremus</i>	8	1.41	2.94	0.38	<u>3.35</u>	0.29	1.00	0.86		1.47	2.37	
<i>U. s. ladinicus</i>	9	0.63	1.29	1.00	<u>4.83</u>	1.95	2.81	2.48	1.69		0.68	
<i>U. arctos</i>	10	2.73	0.28	2.30	<u>9.07</u>	<u>4.07</u>	<u>6.07</u>	<u>4.81</u>	<u>3.74</u>	1.38		
				Dd								
<i>U. deningeri</i>	1		2.65	0.58	2.26	1.94	2.74	1.81	1.51	1.48	0.40	
<i>U. rossicus</i>	2	2.22		3.01	<u>4.40</u>	<u>3.74</u>	<u>4.70</u>	<u>3.70</u>	<u>3.56</u>	0.97	2.09	
<i>U. k. praekudarensis</i>	3	1.13	2.57		1.46	1.48	1.99	1.32	0.97	1.87	0.88	
<i>U. k. kudarensis</i>	4	<u>5.52</u>	<u>5.93</u>	1.83		0.61	0.79	0.37	0.12	3.15	2.28	
<i>U. s. spelaeus</i>	5	2.17	<u>3.56</u>	0.62	1.29		0.13	0.21	0.60	2.81	2.08	
<i>U. k. ingressus</i>	6	2.07	<u>3.66</u>	0.05	<u>3.43</u>	0.81		0.14	0.66	<u>3.50</u>	2.71	
<i>U. k. kanivetz</i>	7	2.14	<u>3.65</u>	0.33	2.24	0.41	0.45		0.39	2.73	1.96	
<i>U. s. eremus</i>	8	1.09	2.88	0.38	<u>3.53</u>	1.23	0.68	0.98		2.52	1.69	
<i>U. s. ladinicus</i>	9	0.75	1.27	1.52	<u>4.62</u>	2.43	2.26	2.37	1.54		1.03	
<i>U. arctos</i>	10	1.75	0.69	2.21	<u>6.31</u>	<u>3.30</u>	<u>3.49</u>	<u>3.43</u>	2.54	0.72		

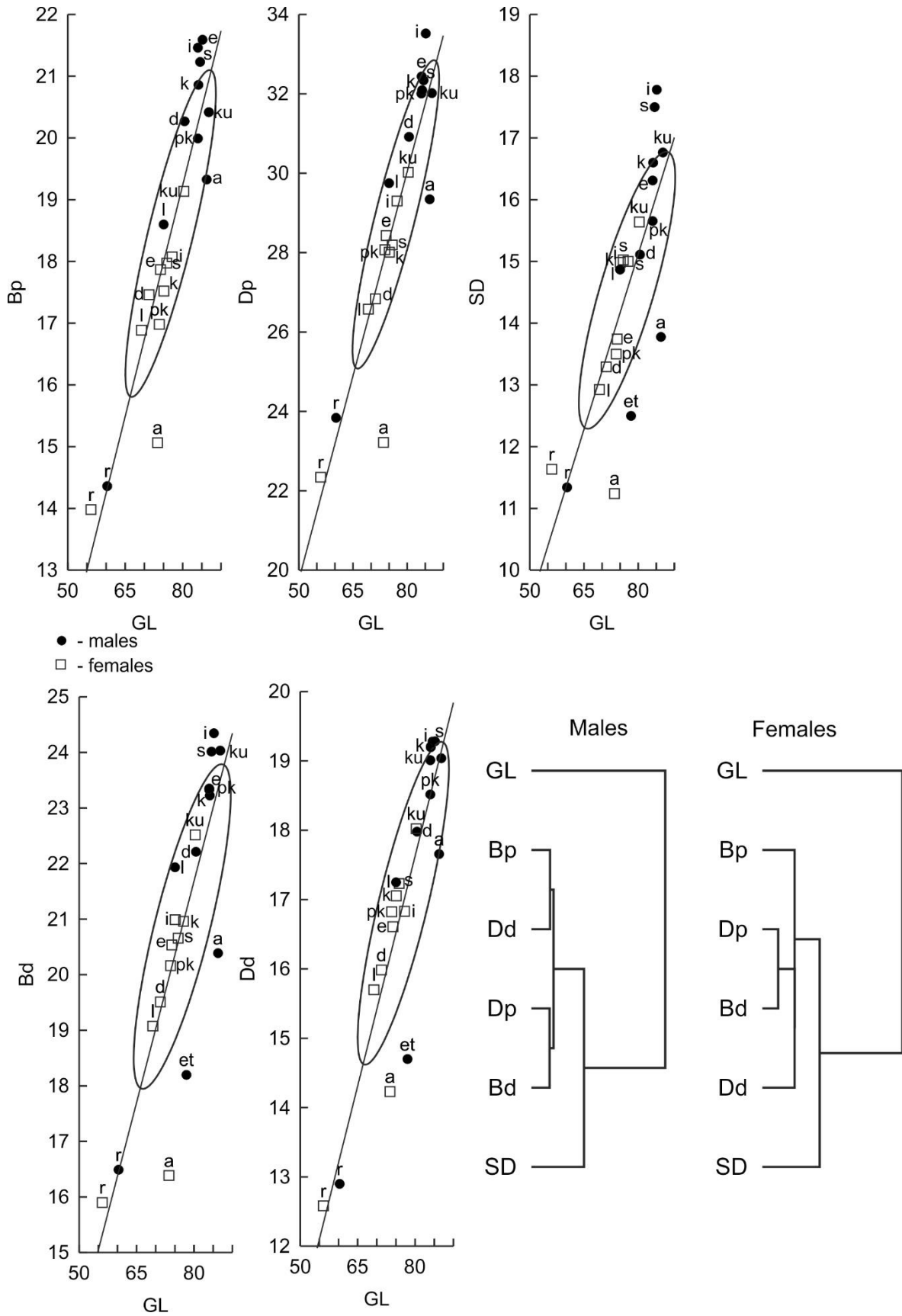

Fig. S11. The scatterplots of measures (GL – Dd) of mtt III and their UPMGA classification, and single linkage dendrograms of measurements based on the correlation metric. et – *U. etruscus*, a – *U. arctos*, r – *U. rossicus*, d – *U. deningeri*, pk – *U. k. praekudarensis*, ku – *U. k. kudarensis*, s – *U. s. spelaeus*, k – *U. k. kanivetz*, U, i – *U. k. ingressus*, e – *U. s. eremus*, l – *U. s. ladinicus*..

Table S18. Statistical parameters of measures of mtt III among different bears and sexes: m – males, f – females.

Taxa	Sex	GL - N	GL	GL Std.De	Bp - N	Bp	Bp Std.De	Dp - N	Dp	Dp Std.De	SD - N	SD	SD Std.De	Bd - N	Bd	Bd Std.De	Dd - N	Dd	Dd Std.De
<i>U. etruscus</i>	m	1	78.0								1	12.5		1	18.2		1	14.7	
<i>U. rossicus</i>	f	6	56.1	0.55	5	14.0	0.24	5	22.3	0.49	6	11.6	0.13	6	15.9	0.19	6	12.6	0.21
	m	11	60.3	0.35	8	14.4	0.50	8	23.8	0.56	7	11.3	0.23	11	16.5	0.22	6	12.9	0.04
<i>U. deningeri</i>	f	21	71.2	0.70	21	17.5	0.31	21	26.8	0.35	21	13.3	0.24	21	19.5	0.27	19	16.0	0.23
	m	17	80.5	0.77	17	20.3	0.43	16	30.9	0.55	17	15.1	0.35	17	22.2	0.50	16	18.0	0.37
<i>U. k. praekudarensis</i>	f	5	73.9	1.44	5	17.0	0.54	4	28.1	0.84	5	13.5	0.39	5	20.2	0.38	4	16.8	0.42
	m	14	84.0	0.71	19	20.0	0.21	18	32.0	0.33	18	15.7	0.25	15	23.3	0.38	13	18.5	0.35
<i>U. k. kudarensis</i>	f	36	80.3	0.42	38	19.1	0.24	36	30.0	0.30	38	15.6	0.16	36	22.5	0.24	33	18.0	0.18
	m	32	86.8	0.41	37	20.4	0.24	34	32.0	0.29	38	16.8	0.20	33	24.0	0.26	30	19.0	0.13
<i>U. s. spelaeus</i>	f	12	75.9	0.79	12	18.0	0.27	10	28.2	0.67	12	15.0	0.20	12	20.7	0.25	6	17.2	0.22
	m	6	84.6	1.35	6	21.2	0.64	5	32.3	0.77	6	17.5	0.38	6	24.0	0.67	5	19.3	0.45
<i>U. k. ingressus</i>	f	32	77.2	0.41	17	18.1	0.22	16	29.3	0.26	32	15.0	0.15	32	21.0	0.16	22	16.8	0.18
	m	23	85.2	0.55	10	21.6	0.47	9	33.5	0.50	23	17.8	0.22	23	24.3	0.28	19	19.3	0.21
<i>U. k. kanivetz</i>	f	14	75.1	0.54	14	17.5	0.33	12	28.0	0.50	14	15.0	0.24	13	21.0	0.27	11	17.1	0.15
	m	8	84.1	0.67	10	20.9	0.58	9	32.1	1.04	10	16.6	0.44	8	23.2	0.59	6	19.2	0.34
<i>U. s. eremus</i>	f	12	74.2	0.76	12	17.9	0.30	12	28.4	0.34	12	13.7	0.17	12	20.5	0.22	12	16.6	0.20
	m	8	84.0	1.27	8	21.5	0.33	8	32.4	0.58	8	16.3	0.34	8	23.4	0.42	8	19.0	0.33
<i>U. s. ladinicus</i>	f	8	69.3	0.51	8	16.9	0.64	8	26.6	0.43	8	12.9	0.24	8	19.1	0.35	7	15.7	0.18
	m	6	75.0	0.91	6	18.6	0.68	6	29.8	0.67	6	14.9	0.51	6	21.9	0.50	6	17.3	0.20
<i>U. arctos</i>	f	22	73.5	0.93	22	15.1	0.27	10	23.2	0.75	22	11.2	0.27	22	16.4	0.32	10	14.2	0.45
	m	8	86.3	3.22	8	19.3	1.33	7	29.3	1.72	9	13.8	0.64	9	20.4	0.71	9	17.7	0.62

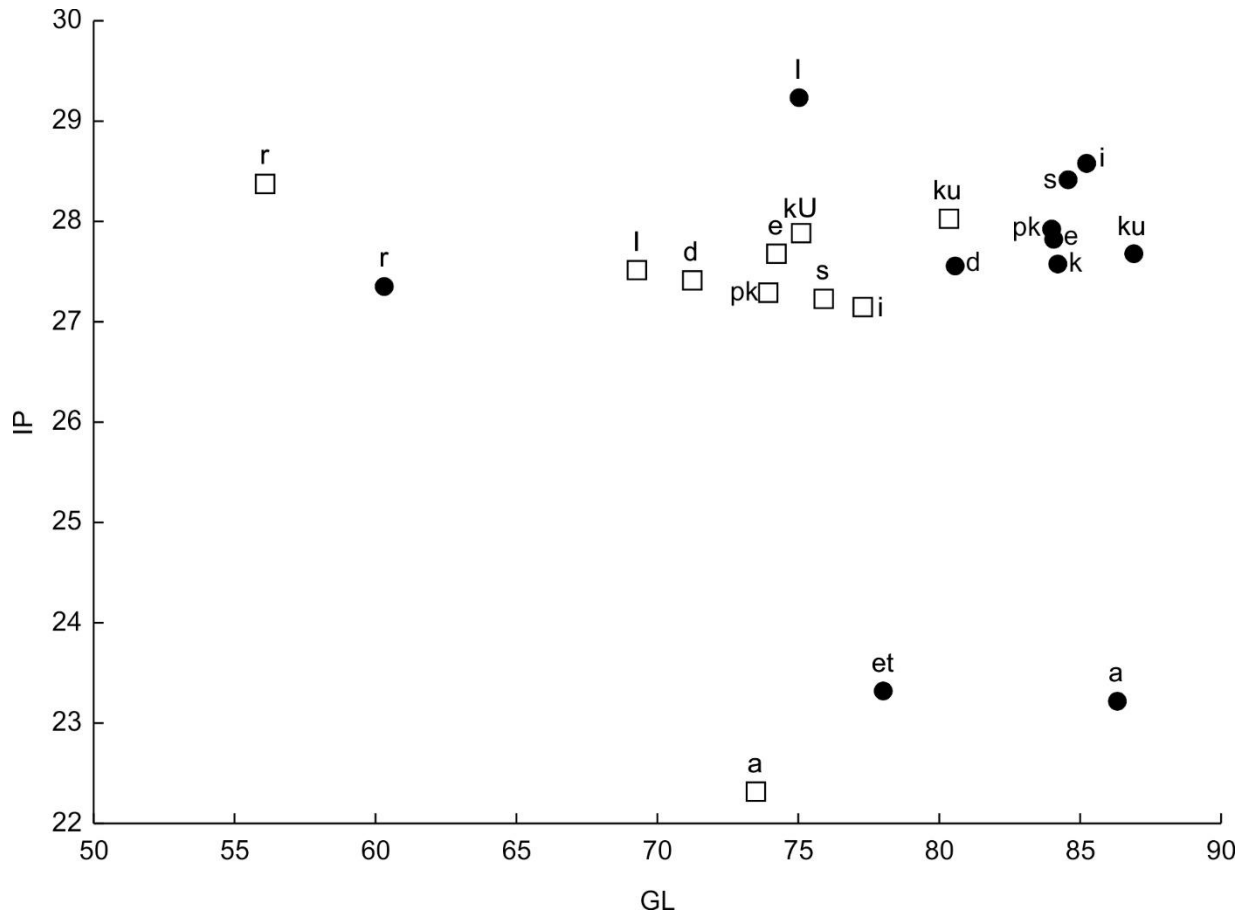

Fig. S12. The scatterplot of Index plumpness (ip) and GL of mtt III: et – *U. etruscus*, a – *U. arctos*, r – *U. rossicus*, d – *U. deningeri*, pk – *U. k. praekudarensis*, ku – *U. k. kudarensis*, s – *U. s. spelaeus*, k – *U. k. kanivetz*, U, i – *U. k. ingressus*, e – *U. s. eremus*, l – *U. s. ladinicus*. Point – males, square – females.

### Multivariate analysis

Table S19. Description of the modeled morphological spaces for males of cave bears and brown bear mtt III. Correlation coefficients among the measures and dimensions of two morphospace models (MDS axes: E, K1–K2);  $r^2$  – coefficients of determination in the linear multiple regression models.

Measures	Morphospaces with <i>U. arctos</i>				Morphospaces without <i>U. arctos</i>			
	“Size”		“Shape”		“Size”		“Shape”	
	morphospace	morphospace		$r^2$	morphospace	morphospace		$r^2$
	E	K1	K2		E	K1	K2	
GL	0.89	0.35	0.17	0.91	0.94	0.21	0.16	0.91
Bp	0.91	0.24	-0.31	0.93	0.90	-0.31	0.21	0.95
Dp	0.94	0.01	-0.15	0.90	0.92	-0.01	-0.16	0.94
SD	0.91	-0.20	0.09	0.91	0.90	0.22	0.01	0.84
Bd	0.95	-0.10	-0.02	0.94	0.95	0.15	0.13	0.91
Dd	0.96	0.14	0.02	0.92	0.95	0.10	0.22	0.91
ip	0.30	-0.54	-0.30		0.29	-0.07	-0.06	
Relative variance (%) of dimensions associated with taxonomical composition								
	55.2	38.7	17.1		56.6	11.0	16.5	

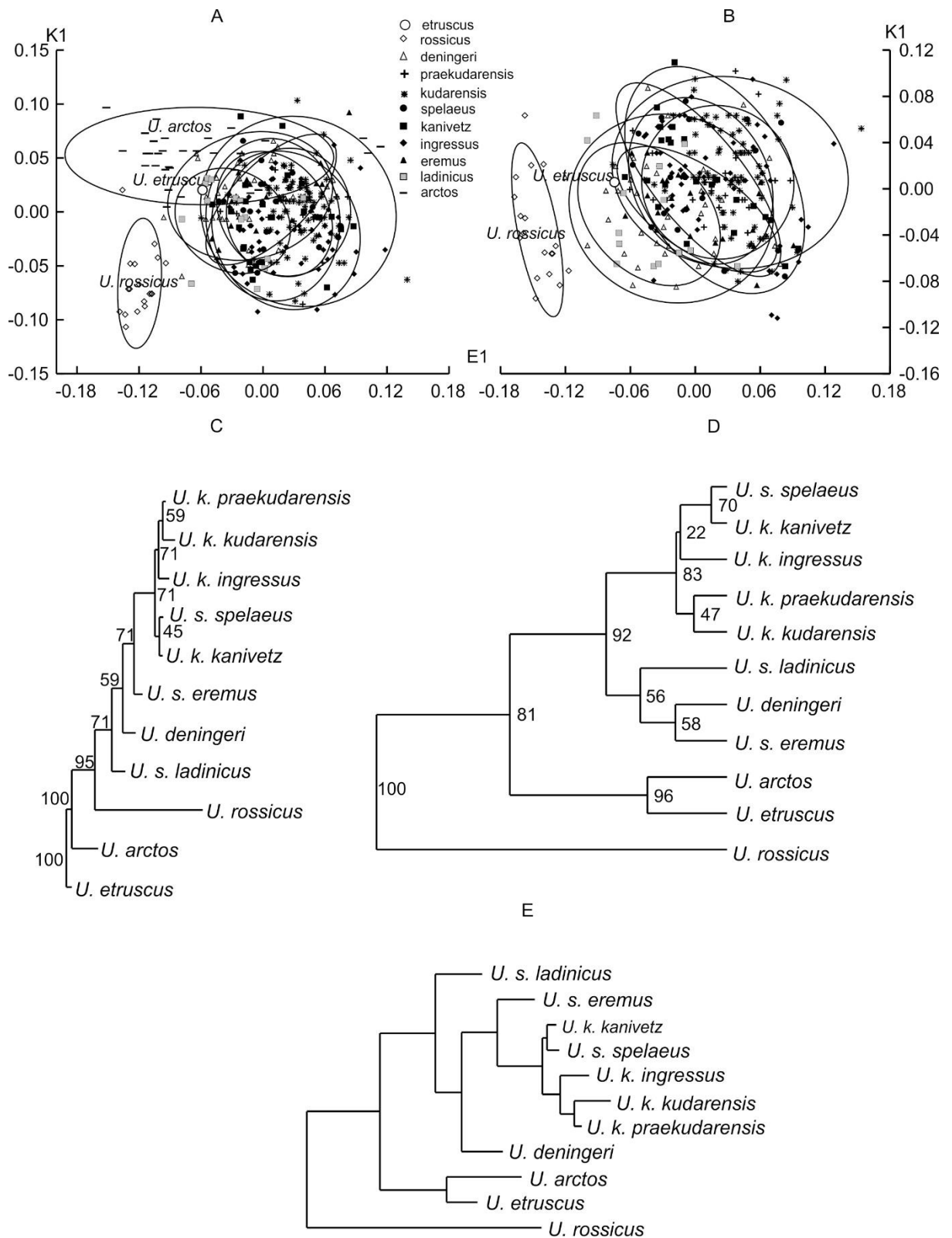

Fig. S13. Scatterplot of the first dimensions of “size” (E1) and “shape” (K1) morphospaces reproduced variation of mtt III in males and females: A – models with *U. arctos*; B – model without *U. arctos*; C – NJ tree; D – UGMA dendrogram (cophenetic correlation – 0.96); E – Sattath-Tversky (Sattath, Tversky, 1977) additive tree. All classifications based on the coordinates of samples’ centroids in the “size” (E) and “shape” (K1, K2) morphospaces (numbers near the nodes - bootstrap (1000 repeats) supports in %). Ellipses’ horizontal and vertical projection onto the E1 and K1 axes are equal to the “sample mean” (centroid)  $\pm$  “sample range”  $\times$  0.95.

**Males**

Table S20. Description of the modeled morphological spaces for males of cave bears and brown bear mtt III. Correlation coefficients among the measures and dimensions of two morphospace models (MDS axes: E, K1–K3);  $r^2$  – coefficients of determination in the linear multiple regression models.

Measures	Morphospaces with <i>U. arctos</i>				Morphospaces without <i>U. arctos</i>			
	“Size”		“Shape”		“Size”		“Shape”	
	morphospace	morphospace		$r^2$	morphospace	morphospace		$r^2$
	E	K1	K2		E	K1	K2	
GL	0.89	0.42	0.29	0.90	0.93	0.41	0.46	0.91
Bp	0.88	-0.18	0.32	0.94	0.87	-0.18	0.50	0.94
Dp	0.89	0.04	-0.09	0.85	0.88	0.14	0.07	0.88
SD	0.87	0.23	-0.19	0.84	0.87	0.27	0.19	0.79
Bd	0.91	0.25	-0.04	0.86	0.93	0.32	0.35	0.87
Dd	0.94	0.35	0.20	0.90	0.94	0.34	0.47	0.91
ip	0.33	-0.18	-0.37		0.31	-0.03	-0.11	
	Relative variance (%) of dimensions associated with taxonomical composition							
	78.7	30.2	30.9		87.7	27.7	22.7	

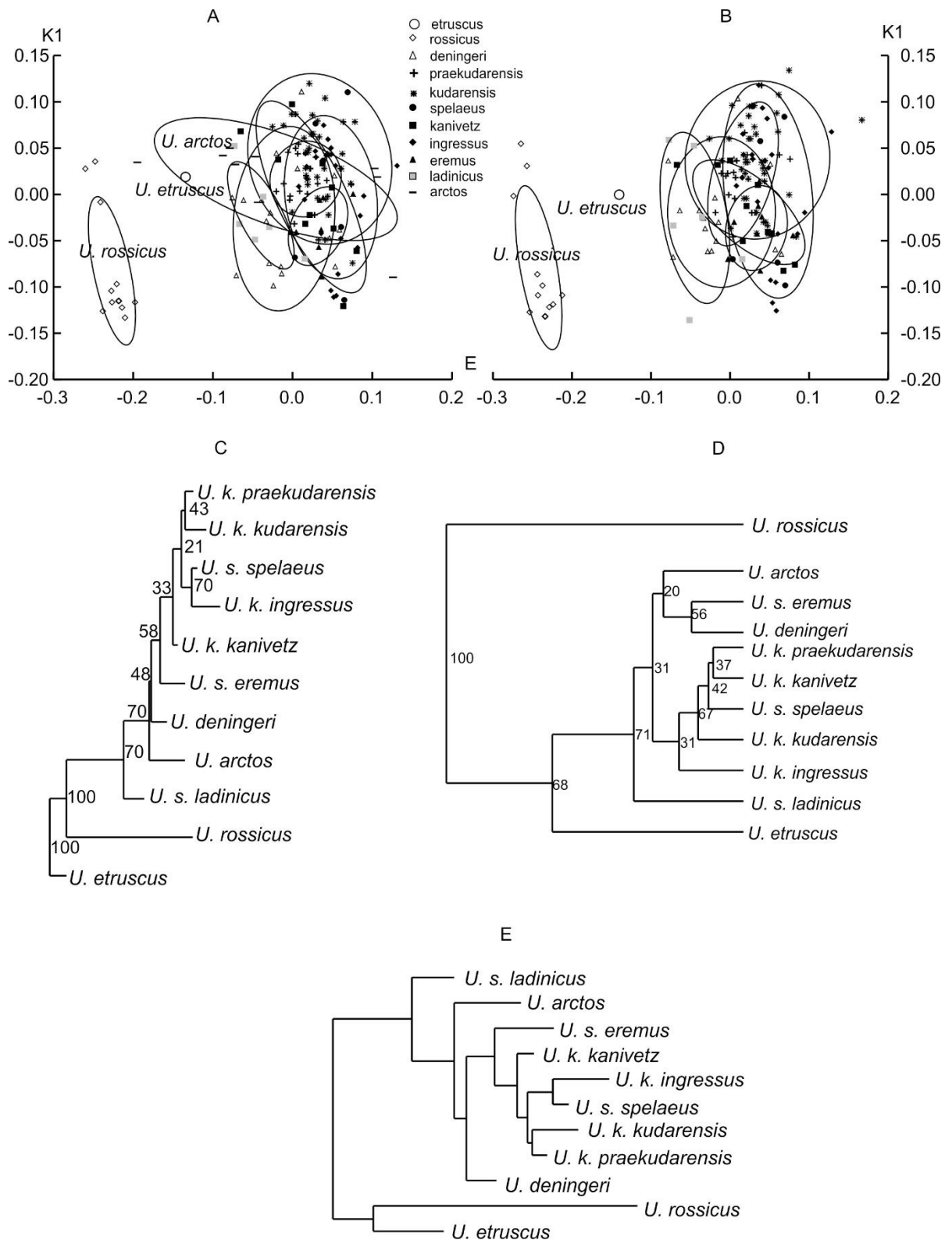

Fig. S14. Scatterplot of the first dimensions of "size" (E1) and "shape" (K1) morphospaces reproduced variation of mtt III in males: A – models with *U. arctos*; B – model without *U. arctos*; C – NJ tree; D – UGMA dendrogram (cophenetic correlation = 0.95); E – Sattath-Tversky (Sattath, Tversky, 1977) additive tree. All classifications based on the coordinates of samples' centroids in the "size" (E) and "shape" (K1, K2) morphospaces (numbers near the nodes - bootstrap (1000 repeats) supports in %). Ellipses' horizontal and vertical projection onto the E1 and K1 axes are equal to the "sample mean" (centroid) ± "sample range" x 0.95.

## Females

Table S21. Description of the modeled morphological spaces for females of cave bears and brown bear mtt III. Correlation coefficients among the measures and dimensions of two morphospace models (MDS axes: E, E1–E2, K1–K2);  $r^2$  – coefficients of determination in the linear multiple regression models.

Measures	Morphospaces with <i>U. arctos</i>				Morphospaces without <i>U. arctos</i>				$r^2$
	“Size”		“Shape”		“Size”		“Shape”		
	morphospace	morphospace	morphospace	morphospace	morphospace	morphospace	morphospace	morphospace	
	E	K1	K2		E1	E2	K1	K2	
GL	0.82	0.18	0.36	0.76	0.92	0.06	0.12	0.48	0.89
Bp	0.88	0.15	-0.02	0.81	0.83	0.43	-0.12	-0.03	0.88
Dp	0.94	0.09	-0.14	0.93	0.91	0.19	-0.02	0.27	0.86
SD	0.91	-0.37	0.02	0.95	0.91	-0.34	0.54	0.25	0.97
Bd	0.96	-0.19	-0.03	0.96	0.95	-0.07	0.31	0.35	0.90
Dd	0.95	0.09	0.13	0.91	0.93	0.18	0.06	0.26	0.88
ip	0.19	-0.42	-0.39		0.21	-0.24	0.35	-0.09	
	Relative variance (%) of dimensions associated with taxonomical composition								
	81.2	17.9	18.6		76.4	11.8	21.4	28.7	



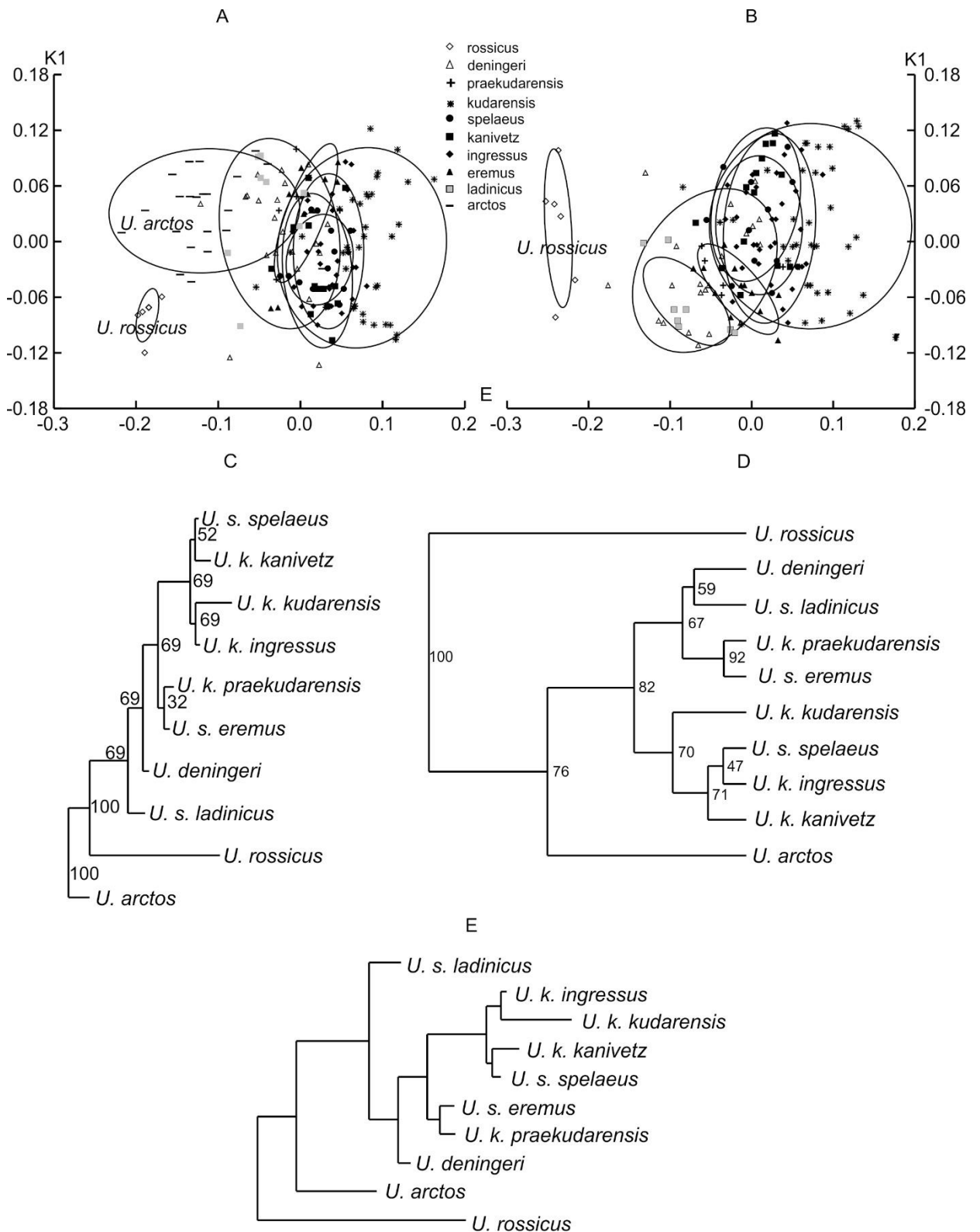

Fig. S15. Scatterplot of the first dimensions of “size” (E1) and “shape” (K1) morphospaces reproduced variation of mtt III in females: A – models with *U. arctos*; B – model without *U. arctos*; C – NJ tree; D – UGMA dendrogram (cophenetic correlation – 0.95); E – Sattath-Tversky (Sattath, Tversky, 1977) additive tree. All classifications based on the coordinates of samples’ centroids in the “size” (E, E1, E2) and “shape” (K1, K2) morphospaces (numbers near the nodes - bootstrap (1000 repeats) supports in %). Ellipses’ horizontal and vertical projection onto the E1 and K1 axes are equal to the “sample mean” (centroid) ± “sample range” x 0.95.

**METATARSAL BONE IV (MTT IV)****Males and females**

Table S22. Sample numbers (N), means (M), and standard errors (m) of the variables of mtt IV among the different forms of bears

Form	GL		Bp		Dp		SD	
	N	M±m	N	M±m	N	M±m	N	M±m
<i>U. etruscus</i>	2	78.5					2	12.05
<i>U. deningeri</i>	37	82.0±0.80	37	20.6±0.26	36	27.7±0.43	38	14.9±0.23
<i>U. k. praekudarensis</i>	16	89.9±1.84	19	24.0±0.66	17	30.1±0.79	19	16.7±0.39
<i>U. k. kudarensis</i>	80	93.4±0.58	96	24.2±0.27	90	31.7±0.28	96	17.7±0.15
<i>U. rossicus</i>	28	64.5±0.57	20	16.9±0.31	20	22.4±0.33	20	12.2±0.16
<i>U. s. spelaeus</i>	18	86.6±1.33	18	21.5±0.46	13	31.7±0.81	18	16.0±0.30
<i>U. k. kanivetz</i>	20	82.5±1.53	22	20.2±0.45	19	29.3±0.75	22	15.9±0.32
<i>U. s. eremus</i>	20	86.6±1.11	20	20.1±0.26	20	32.4±0.73	20	15.7±0.36
<i>U. s. ladinicus</i>	12	82.4±1.89	12	19.3±0.50	12	30.5±1.02	12	14.1±0.48
<i>U. k. ingressus</i>	53	87.3±0.81	24	22.5±0.38	23	31.8±0.53	55	16.3±0.23
<i>U. arctos</i>	23	84.3±1.75	23	18.8±0.57	18	25.9±0.86	23	12.5±0.37
			<b>Bd</b>		<b>Dd</b>			
			N	M±m	N	M±m		
<i>U. etruscus</i>			2	18.1	2	13.8		
<i>U. deningeri</i>			36	22.5±0.32	36	17.7±0.22		
<i>U. k. praekudarensis</i>			15	24.7±0.66	13	19.4±0.63		
<i>U. k. kudarensis</i>			79	26.3±0.22	72	20.0±0.13		
<i>U. rossicus</i>			28	17.7±0.17	18	13.6±0.16		
<i>U. s. spelaeus</i>			17	23.5±0.50	5	19.1±0.78		
<i>U. k. kanivetz</i>			19	23.0±0.51	15	17.5±0.45		
<i>U. s. eremus</i>			20	23.8±0.38	20	19.1±0.27		
<i>U. s. ladinicus</i>			12	22.3±0.66	9	17.8±0.45		
<i>U. k. ingressus</i>			53	23.7±0.29	37	18.7±0.21		
<i>U. arctos</i>			23	19.0±0.50	17	16.3±0.50		

**Sexual dimorphism**Table S23. Sexual size dimorphism (SSD and ASSD) of mtt IV in the different forms of cave bears and brown bear; *p* based on Mann-Whitney U Test; *v*, % - relative variance associated with SSD.

	Measures						ASSD
	GL	Bp	Dp	SD	Bd	Dd	
	<i>U. deningeri</i>						
Males	86.6±1.00	21.6±0.47	30.1±0.54	16.1±0.39	23.9±0.51	18.6±0.29	
Females	79.0±0.51	19.9±0.24	26.2±0.31	14.2±0.15	21.6±0.28	17.0±0.20	
SSD	4.6±0.68	3.9±1.26	7.0±1.10	6.3±1.38	5.1±1.29	4.6±1.00	5.2
<i>v</i> , %	( <i>p</i> <0.001) 76.4	( <i>p</i> <0.001) 32.5	( <i>p</i> <0.001) 72.8	( <i>p</i> <0.001) 59.5	( <i>p</i> <0.001) 49.0	( <i>p</i> <0.001) 60.7	
	<i>U. rossicus</i>						
Males	66.4±0.38	17.3±0.43	23.0±0.25	12.6±0.15	18.0±0.14	13.8±0.12	
Females	61.1±0.55	16.2±0.25	21.2±0.60	11.6±0.21	17.0±0.27	13.1±0.32	
SSD	4.1±0.52	3.1±1.49	4.2±1.46	3.9±1.07	3.1±0.88	n.s.	3.5



## Univariate analysis

Table S24. Kruskal-Wallis test z' values (males - above diagonal and females – under diagonal) for measures of mtt IV. The statistical significance values, according to 2-tailed *p* values, have been underlined.

Taxa		1	2	3	4	5	6	7	8	9	10
		GL									
<i>U. deningeri</i>	1		1.83	<u>3.40</u>	<u>5.47</u>	1.95	2.83	1.67	1.58	1.36	1.24
<i>U. rossicus</i>	2	2.15		<u>5.09</u>	<u>8.17</u>	<u>3.36</u>	<u>4.85</u>	2.97	3.06	2.41	2.91
<i>U. k. praekudarensis</i>	3	1.99	<u>3.41</u>		0.50	0.93	1.05	1.03	1.42	0.86	2.02
<i>U. k. kudarensis</i>	4	<u>7.01</u>	<u>7.62</u>	2.59		1.56	2.18	1.61	2.22	1.27	3.19
<i>U. s. spelaeus</i>	5	2.93	<u>4.37</u>	0.40	2.63		0.12	0.14	0.40	0.12	0.84
<i>U. k. ingressus</i>	6	<u>4.30</u>	<u>5.55</u>	0.73	3.20	0.34		0.28	0.62	0.23	1.24
<i>U. k. kanivetz</i>	7	0.51	2.42	1.51	<u>5.66</u>	2.28	3.24		0.24	0.00	0.64
<i>U. s. eremus</i>	8	3.10	<u>4.53</u>	0.47	2.61	0.08	0.25	2.42		0.20	0.43
<i>U. s. ladinicus</i>	9	0.35	2.09	1.44	<u>4.78</u>	2.07	2.75	0.07	2.18		0.54
<i>U. arctos</i>	10	0.83	2.63	1.22	<u>5.03</u>	1.90	2.71	0.31	2.03	0.34	
		Bp									
<i>U. deningeri</i>	1		2.74	<u>3.51</u>	3.16	1.47	1.69	0.26	0.41	0.30	0.48
<i>U. rossicus</i>	2	3.14		<u>6.04</u>	<u>6.50</u>	<u>3.59</u>	<u>3.81</u>	2.26	1.85	1.35	2.04
<i>U. k. praekudarensis</i>	3	1.57	<u>3.86</u>		1.43	1.38	1.17	2.38	<u>3.33</u>	2.47	<u>3.69</u>
<i>U. k. kudarensis</i>	4	<u>4.67</u>	<u>6.29</u>	1.49		0.53	0.28	1.73	2.83	1.91	<u>3.32</u>
<i>U. s. spelaeus</i>	5	0.66	<u>3.34</u>	0.90	3.00		0.19	0.96	1.63	1.28	1.77
<i>U. k. ingressus</i>	6	2.88	<u>5.08</u>	0.62	1.11	1.81		1.14	1.82	1.43	1.98
<i>U. k. kanivetz</i>	7	0.56	2.62	1.92	<u>4.84</u>	1.10	3.21		0.56	0.44	0.61
<i>U. s. eremus</i>	8	0.65	2.41	1.93	<u>4.53</u>	1.15	3.11	0.12		0.00	0.01
<i>U. s. ladinicus</i>	9	1.57	1.46	2.60	<u>4.99</u>	1.93	<u>3.74</u>	1.06	0.91		0.01
<i>U. arctos</i>	10	3.21	0.52	<u>3.90</u>	<u>7.31</u>	<u>3.36</u>	<u>5.55</u>	2.53	2.26	1.14	
		Dp									
<i>U. deningeri</i>	1		2.36	1.84	3.13	2.76	2.35	1.95	<u>3.87</u>	2.48	0.77
<i>U. rossicus</i>	2	1.71		<u>3.91</u>	<u>5.97</u>	<u>4.46</u>	<u>4.17</u>	<u>3.66</u>	<u>5.77</u>	<u>3.89</u>	1.40
<i>U. k. praekudarensis</i>	3	1.19	2.39		0.43	1.17	0.69	0.42	2.00	1.19	2.41
<i>U. k. kudarensis</i>	4	<u>5.02</u>	<u>5.08</u>	2.19		1.06	0.48	0.16	2.12	1.07	<u>3.65</u>
<i>U. s. spelaeus</i>	5	3.10	<u>3.91</u>	1.58	0.17		0.48	0.66	0.61	0.20	3.21
<i>U. k. ingressus</i>	6	<u>5.23</u>	<u>5.41</u>	2.79	1.17	0.95		0.22	1.16	0.61	2.84
<i>U. k. kanivetz</i>	7	1.63	2.81	0.14	2.52	1.63	3.13		1.33	0.77	2.44
<i>U. s. eremus</i>	8	<u>4.56</u>	<u>4.99</u>	2.45	0.78	0.70	0.25	2.70		0.31	<u>4.29</u>
<i>U. s. ladinicus</i>	9	2.30	<u>3.28</u>	0.86	1.18	0.77	1.89	0.82	1.58		2.89
<i>U. arctos</i>	10	1.23	0.46	2.00	<u>4.76</u>	<u>3.57</u>	<u>5.12</u>	2.40	<u>4.68</u>	2.91	
		SD									
<i>U. deningeri</i>	1		2.33	2.43	<u>4.11</u>	1.02	<u>3.68</u>	1.55	1.39	0.20	1.50
<i>U. rossicus</i>	2	2.10		<u>4.51</u>	<u>6.76</u>	2.79	<u>5.94</u>	3.20	3.24	1.58	0.65
<i>U. k. praekudarensis</i>	3	1.46	2.91		0.69	0.93	0.88	0.30	0.68	1.29	<u>3.61</u>
<i>U. k. kudarensis</i>	4	<u>6.41</u>	<u>6.31</u>	2.80		1.63	0.40	0.84	1.39	1.80	<u>5.26</u>
<i>U. s. spelaeus</i>	5	2.49	<u>3.77</u>	0.63	2.43		1.71	0.51	0.25	0.52	2.14
<i>U. k. ingressus</i>	6	3.09	<u>4.19</u>	0.56	<u>3.81</u>	0.21		0.99	1.49	1.89	<u>4.81</u>
<i>U. k. kanivetz</i>	7	2.52	<u>3.81</u>	0.48	3.03	0.21	0.04		0.28	0.93	2.58
<i>U. s. eremus</i>	8	1.19	2.81	0.41	<u>3.97</u>	1.18	1.26	1.06		0.74	2.53
<i>U. s. ladinicus</i>	9	1.27	0.81	2.26	<u>5.91</u>	3.14	<u>3.55</u>	3.16	2.10		1.12
<i>U. arctos</i>	10	2.70	0.06	<u>3.41</u>	<u>8.19</u>	<u>4.55</u>	<u>5.45</u>	<u>4.72</u>	<u>3.44</u>	1.01	
		Bd									

Taxa		1	2	3	4	5	6	7	8	9	10
<i>U. deningeri</i>	1		2.63	2.61	<u>4.21</u>	0.96	2.04	1.67	1.34	0.80	1.41
<i>U. rossicus</i>	2	3.11		<u>4.94</u>	<u>8.00</u>	2.99	<u>4.95</u>	<u>3.57</u>	<u>3.50</u>	2.32	0.90
<i>U. k. praekudarensis</i>	3	0.95	3.24		0.33	1.27	0.99	0.51	1.04	0.96	<u>3.68</u>
<i>U. k. kudarensis</i>	4	<u>5.46</u>	<u>7.45</u>	2.62		1.87	1.93	0.88	1.63	1.30	<u>5.36</u>
<i>U. s. spelaeus</i>	5	1.13	<u>3.67</u>	0.01	3.12		0.56	0.66	0.27	0.05	2.05
<i>U. k. ingressus</i>	6	1.77	<u>4.66</u>	0.16	<u>4.25</u>	0.18		0.26	0.25	0.36	<u>3.31</u>
<i>U. k. kanivetz</i>	7	0.28	3.10	0.68	<u>4.41</u>	0.80	1.22		0.42	0.49	2.65
<i>U. s. eremus</i>	8	1.80	<u>4.32</u>	0.47	2.66	0.52	0.47	1.39		0.16	2.45
<i>U. s. ladinicus</i>	9	0.41	2.23	1.14	<u>4.42</u>	1.29	1.72	0.60	1.83		1.66
<i>U. arctos</i>	10	3.23	0.14	<u>3.29</u>	<u>8.04</u>	<u>3.78</u>	<u>4.97</u>	3.18	<u>4.49</u>	2.23	
					Dd						
<i>U. deningeri</i>	1		2.29	<u>3.94</u>	<u>3.97</u>	1.68	1.46	1.39	2.47	1.14	0.65
<i>U. rossicus</i>	2	2.67		<u>5.61</u>	<u>6.22</u>	3.03	<u>3.63</u>	2.90	<u>4.22</u>	2.30	1.42
<i>U. k. praekudarensis</i>	3	0.41	2.44		1.52	1.08	2.78	1.63	1.26	1.18	<u>4.12</u>
<i>U. k. kudarensis</i>	4	<u>5.18</u>	<u>6.30</u>	2.90		0.21	2.19	0.78	0.13	0.45	<u>3.99</u>
<i>U. s. spelaeus</i>	5	0.42	1.84	0.15	1.62		0.83	0.37	0.10	0.22	2.00
<i>U. k. ingressus</i>	6	2.33	<u>4.33</u>	1.13	2.76	0.54		0.44	1.31	0.43	1.91
<i>U. k. kanivetz</i>	7	0.66	1.90	0.86	<u>4.90</u>	0.73	2.59		0.56	0.09	1.75
<i>U. s. eremus</i>	8	2.95	<u>4.71</u>	1.72	1.36	0.96	0.95	3.14		0.34	2.79
<i>U. s. ladinicus</i>	9	0.10	2.26	0.26	<u>3.44</u>	0.33	1.54	0.60	2.13		1.45
<i>U. arctos</i>	10	2.34	0.38	2.15	<u>6.15</u>	1.62	<u>4.07</u>	1.56	<u>4.48</u>	1.96	

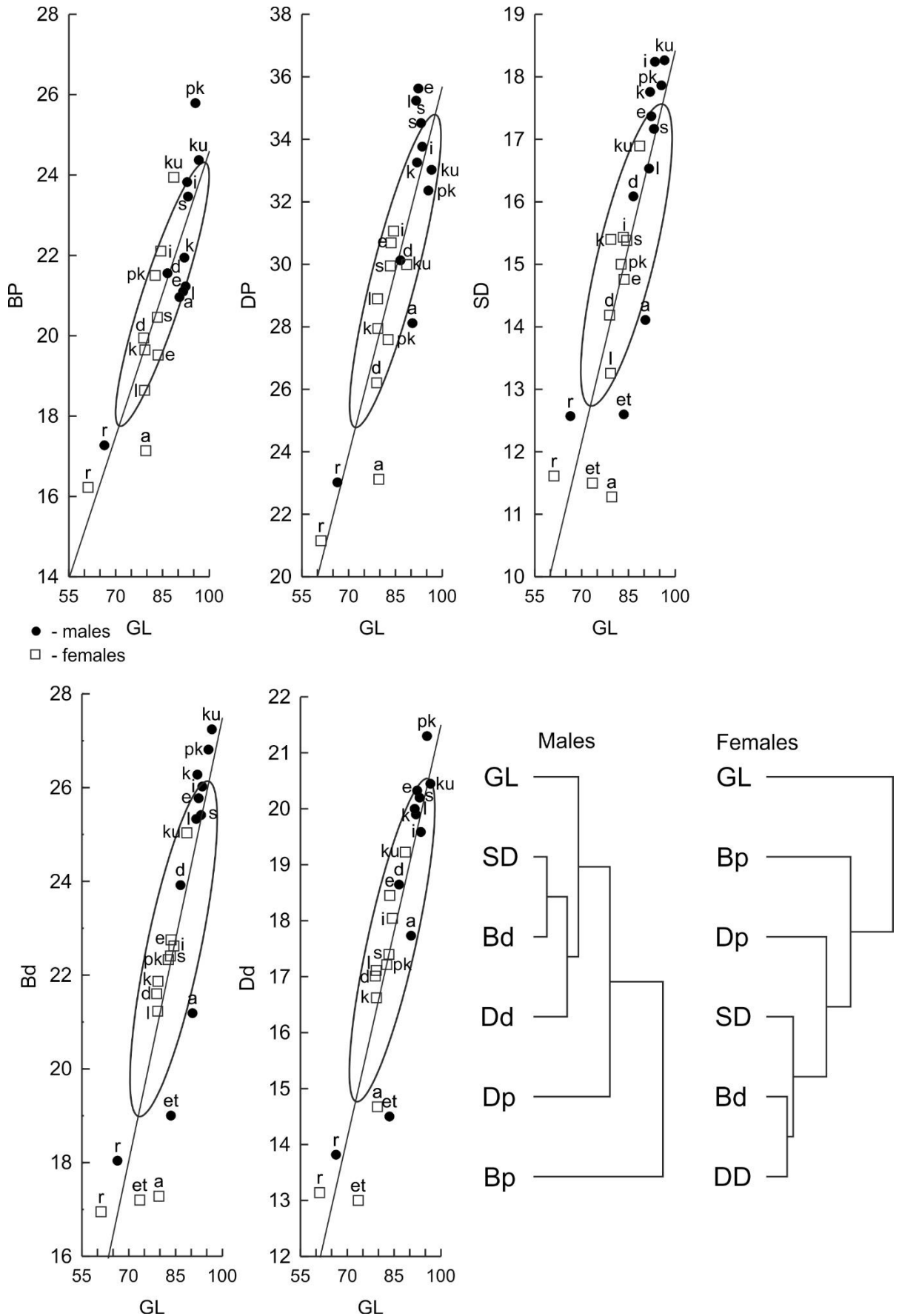

Fig. S16. The scatterplots of measures (GL – Dd) of mtt IV and their UPMGA classification, and single linkage dendrograms of measurements based on the correlation metric. et – *U. etruscus*, a – *U. arctos*, r – *U. rossicus*, d – *U. deningeri*, pk – *U. k. praekudarensis*, ku – *U. k. kudarensis*, s – *U. s. spelaeus*, k – *U. k. kanivetz*, i – *U. k. ingressus*, e – *U. s. eremus*, l – *U. s. ladinicus*.

Table S25. Statistical parameters of measures of mtt IV among different bears and sexes: m – males, f – females.

Taxa	Sex	GL - N	GL	GL Std.De	Bp - N	Bp	Bp Std.De	Dp - N	Dp	Dp Std.De	SD - N	SD	SD Std.De	Bd - N	Bd	Bd Std.De	Dd - N	Dd	Dd Std.De
<i>U. etruscus</i>	m	1	73.5								1	11.5		1	17.2		1	13.0	
	f	1	83.5								1	12.6		1	19.0		1	14.5	
<i>U. rossicus</i>	f	10	61.1	0.55	7	16.2	0.25	7	21.2	0.60	7	11.6	0.21	10	17.0	0.27	7	13.1	0.32
	m	18	66.4	0.38	13	17.3	0.43	13	23.0	0.25	13	12.6	0.15	18	18.0	0.14	11	13.8	0.12
<i>U. deningeri</i>	f	22	79.0	0.51	23	19.9	0.24	22	26.2	0.31	23	14.2	0.15	22	21.6	0.28	21	17.0	0.20
<i>U. k. praekudarensis</i>	m	15	86.6	1.00	14	21.6	0.47	14	30.1	0.54	15	16.1	0.39	14	23.9	0.51	15	18.6	0.29
	f	7	82.6	1.12	8	21.5	0.61	8	27.6	0.90	8	15.0	0.27	7	22.3	0.32	6	17.2	0.34
<i>U. k. kudarensis</i>	m	9	95.5	1.22	11	25.8	0.64	9	32.4	0.63	11	17.9	0.28	8	26.8	0.46	7	21.3	0.36
	f	32	88.6	0.57	40	23.9	0.43	38	30.0	0.33	39	16.9	0.20	33	25.0	0.27	28	19.2	0.17
<i>U. s. spelaeus</i>	m	48	96.6	0.50	56	24.4	0.35	52	33.0	0.33	57	18.3	0.17	46	27.2	0.25	44	20.5	0.15
	f	12	83.3	0.79	12	20.5	0.29	8	30.0	0.53	12	15.4	0.29	11	22.4	0.36	2	17.4	0.80
<i>U. k. ingressus</i>	m	6	93.2	1.51	6	23.5	0.74	5	34.5	1.07	6	17.2	0.41	6	25.4	0.80	3	20.2	0.49
	f	36	84.4	0.64	18	22.1	0.36	17	31.1	0.46	38	15.4	0.18	36	22.6	0.26	22	18.0	0.25
<i>U. k. kanivetz</i>	m	17	93.5	1.05	6	23.8	0.98	6	33.8	1.31	17	18.2	0.25	17	26.0	0.24	15	19.6	0.23
	f	15	79.4	1.00	17	19.6	0.50	14	27.9	0.58	17	15.4	0.30	14	21.9	0.28	11	16.6	0.27
<i>U. s. eremus</i>	m	5	92.0	1.99	5	21.9	0.43	5	33.3	1.19	5	17.8	0.15	5	26.3	0.45	4	19.9	0.50
	f	13	83.6	0.78	13	19.5	0.24	13	30.7	0.66	13	14.8	0.24	13	22.8	0.26	13	18.5	0.22
<i>U. s. ladinicus</i>	m	7	92.3	0.74	7	21.2	0.31	7	35.6	0.76	7	17.4	0.49	7	25.8	0.31	7	20.3	0.31
	f	9	79.3	1.02	9	18.6	0.40	9	28.9	0.62	9	13.3	0.23	9	21.2	0.44	7	17.1	0.21
<i>U. arctos</i>	m	3	91.6	3.05	3	21.1	1.11	3	35.2	1.79	3	16.5	0.71	3	25.3	1.05	2	20.0	0.10
	f	13	79.7	1.37	13	17.1	0.31	8	23.1	0.86	13	11.3	0.26	13	17.3	0.31	8	14.7	0.41
	m	10	90.4	2.60	10	21.0	0.86	10	28.1	0.89	10	14.1	0.38	10	21.2	0.55	9	17.7	0.50

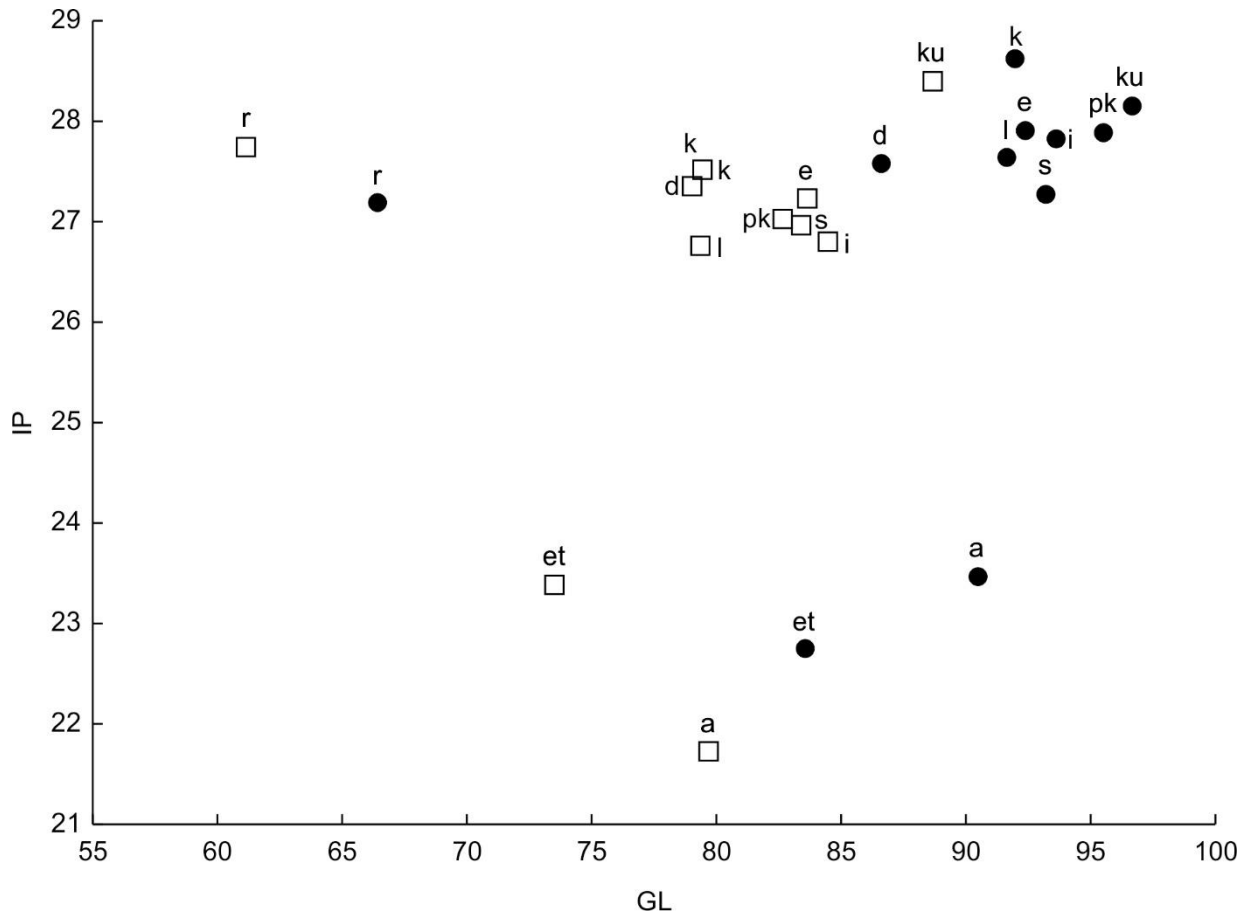

Fig. S17. The scatterplot of Index plumpness (ip) and GL of mtt IV: et – *U. etruscus*, a – *U. arctos*, r – *U. rossicus*, d – *U. deningeri*, pk – *U. k. praekudarensis*, ku – *U. k. kudarensis*, s – *U. s. spelaeus*, k – *U. k. kanivetz*, i – *U. k. ingressus*, e – *U. s. eremus*, l – *U. s. ladinicus*. Point – males, square – females.

**Multivariate analysis**

Table 26. Description of the modeled morphological spaces for cave bears and brown bear mtt IV. Correlation coefficients among the measures and dimensions of two morphospace models (MDS axes: E1–E2, K1–K2);  $r^2$  – coefficients of determination in the linear multiple regression models.

Measures	Morphospaces with <i>U. arctos</i>					Morphospaces without <i>U. arctos</i>				
	“Size”		“Shape”		$r^2$	“Size”		“Shape”		$r^2$
	morphospace		morphospace			morphospace		morphospace		
	E1	E2	K1	K2		E1	E2	K1	K2	
GL	0.92	-0.09	-0.06	-0.02	0.88	0.96	0.08	0.04	0.47	0.92
Bp	0.84	-0.45	0.10	-0.40	0.94	0.82	-0.49	-0.43	0.23	0.98
Dp	0.88	0.22	-0.10	0.29	0.91	0.86	0.32	0.34	0.21	0.92
SD	0.93	0.20	-0.40	-0.06	0.93	0.93	0.16	0.07	0.56	0.89
Bd	0.96	0.15	-0.33	-0.08	0.96	0.97	0.15	0.03	0.60	0.96
Dd	0.96	0.04	-0.15	-0.07	0.92	0.95	0.11	-0.02	0.47	0.92
ip	0.32	0.26	-0.53	-0.23		0.33	0.15	-0.06	0.53	
Relative variance (%) of dimensions associated with taxonomical composition										
	69.4	29.9	15.8	38.1		69.9	25.5	29.8	37.3	



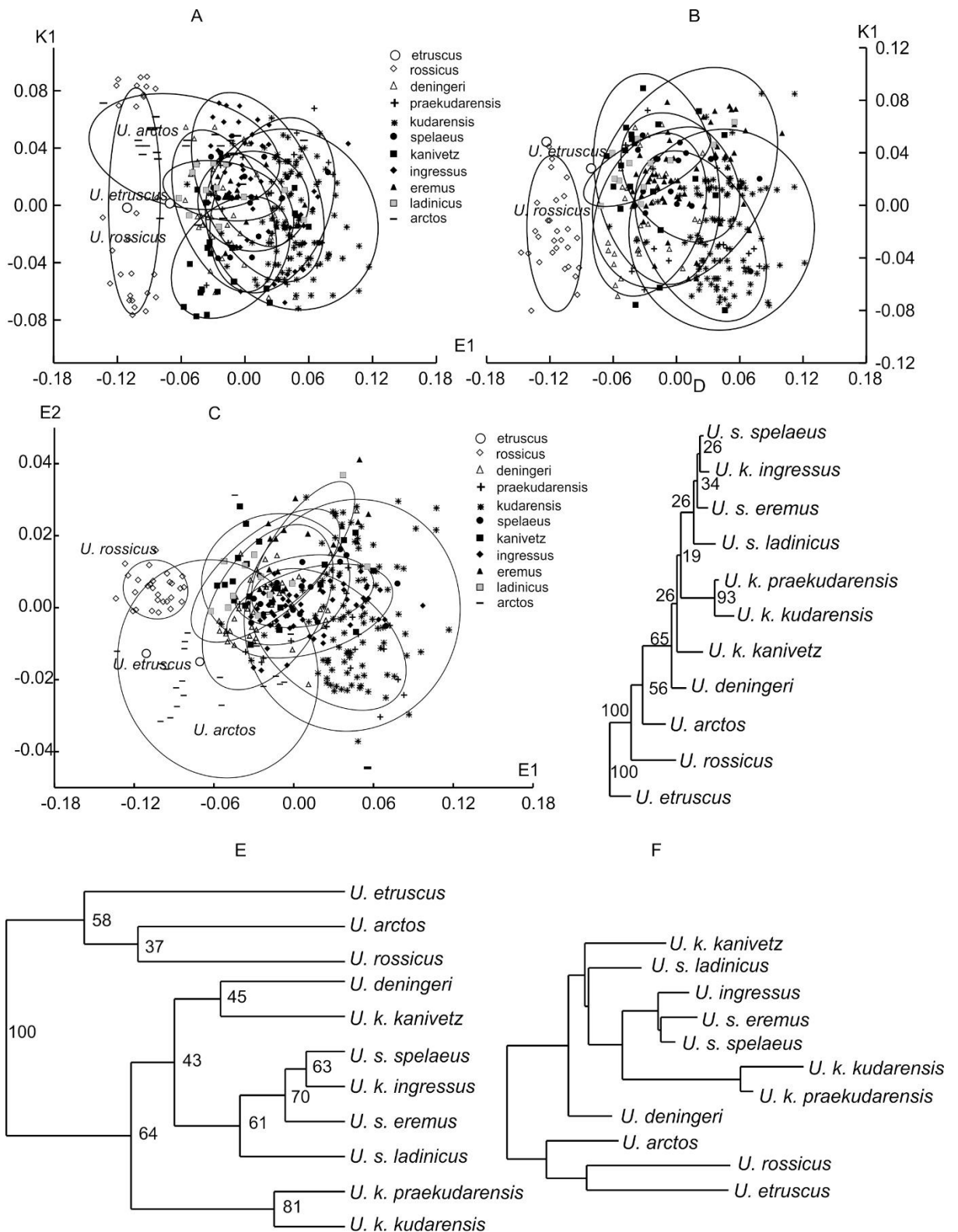

Fig. S18. Scatterplot of the first dimensions of "size" (E1) and "shape" (K1) morphospaces reproduced variation of mtt IV in males and females: A, C – models with *U. arctos*; B – model without *U. arctos*; C – "size" morphospace; D – NJ tree; E – UGMA dendrogram (cophenetic correlation – 0.85); F – Sattath-Tversky (Sattath, Tversky, 1977) additive tree. All classifications based on the coordinates of samples' centroids in the "size" (E1, E2) and "shape" (K1, K2) morphospaces (numbers near the nodes - bootstrap (1000 repeats) supports in %). Ellipses' horizontal and vertical projection onto the E1 (E2) and K1 axes are equal to the "sample mean" (centroid)  $\pm$  "sample range"  $\times$  0.95.

**Males**

Table S27. Description of the modeled morphological spaces for males of cave bears and brown bear metatarsal IV. Correlation coefficients among the measures and dimensions of two morphospace models (MDS axes: E1–E2, K1–K3);  $r^2$  – coefficients of determination in the linear multiple regression models.

Measures	Morphospaces with <i>U. arctos</i>				Morphospaces without <i>U. arctos</i>			
	“Size” morphospace		“Shape” morphospace		“Size” morphospace		“Shape” morphospace	
	E	K1	K2	$r^2$	E	K1	K2	$r^2$
GL	0.93	0.42	0.46	0.88	0.96	0.46	0.51	0.92
Bp	0.78	-0.05	0.55	0.89	0.77	-0.10	0.61	0.91
Dp	0.87	0.59	0.04	0.91	0.86	0.63	0.09	0.91
SD	0.92	0.57	0.39	0.87	0.93	0.55	0.48	0.87
Bd	0.96	0.59	0.48	0.94	0.96	0.56	0.55	0.94
Dd	0.97	0.50	0.49	0.93	0.97	0.50	0.54	0.92
ip	0.34	0.43	0.33		0.33	0.33	0.28	
Relative variance (%) of dimensions associated with taxonomical composition								
	88.5	42.5	40.9		91.7	39.5	41.3	

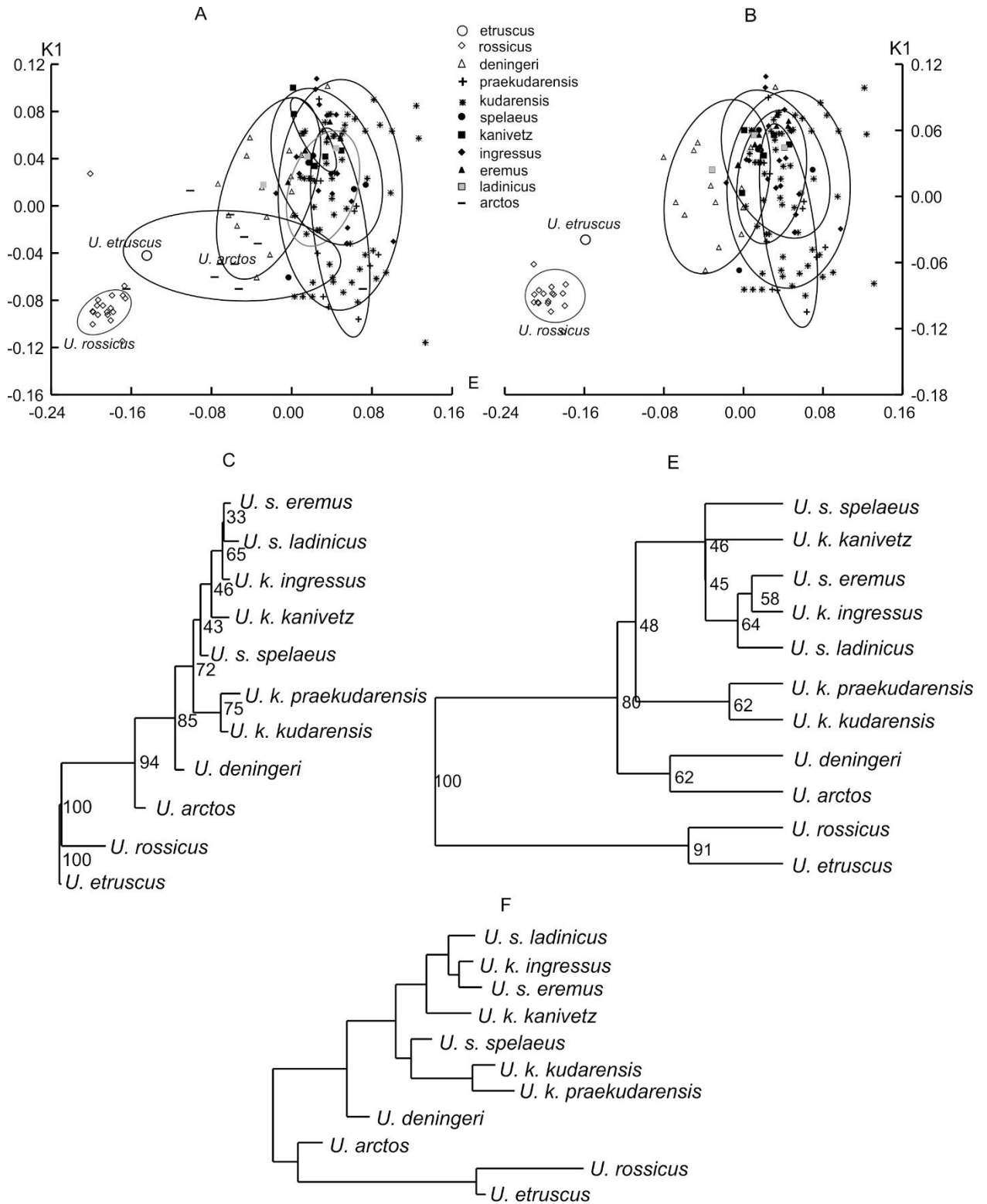

Fig. S19. Scatterplot of the first dimensions of “size” (E1) and “shape” (K1) morphospaces reproduced variation of mtt IV in males: A, C – models with *U. arctos*; B – model without *U. arctos*; C – NJ tree; E – UGMA dendrogram (cophenetic correlation – 0.89); D – Sattath-Tversky (Sattath, Tversky, 1977) additive tree. All classifications based on the coordinates of samples’ centroids in the “size” (E, E1, and E2) and “shape” (K1, K2) morphospaces (numbers near the nodes - bootstrap (1000 repeats) supports in %). Ellipses’ horizontal and vertical projection onto the E1 (E2) and K1 axes are equal to the “sample mean” (centroid) ± “sample range” x 0.95.

## Females

Table S28. Description of the modeled morphological spaces for females of cave bears and brown bear mtt IV. Correlation coefficients among the measures and dimensions of two morphospace models (MDS axes: E, K1–K2);  $r^2$  – coefficients of determination in the linear multiple regression models.

Measures	Morphospaces with <i>U. arctos</i>				Morphospaces without <i>U. arctos</i>			
	“Size” morphospace		“Shape” morphospace		“Size” morphospace		“Shape” morphospace	
	E	K1	K2	$r^2$	E	K1	K2	$r^2$
GL	0.88	-0.04	0.35	0.82	0.95	0.25	0.29	0.88
Bp	0.84	-0.24	0.36	0.79	0.82	0.38	-0.08	0.81
Dp	0.85	0.32	0.03	0.90	0.81	-0.26	0.22	0.88
SD	0.90	-0.29	-0.18	0.93	0.89	0.30	0.55	0.87
Bd	0.95	-0.24	-0.04	0.94	0.95	0.35	0.45	0.92
Dd	0.93	-0.08	0.18	0.88	0.92	0.19	0.26	0.85
ip	0.25	-0.43	-0.37		0.26	0.30	0.41	
Relative variance (%) of dimensions associated with taxonomical composition								
	82.5	51.8	33.1		79.5	52.6	24.0	

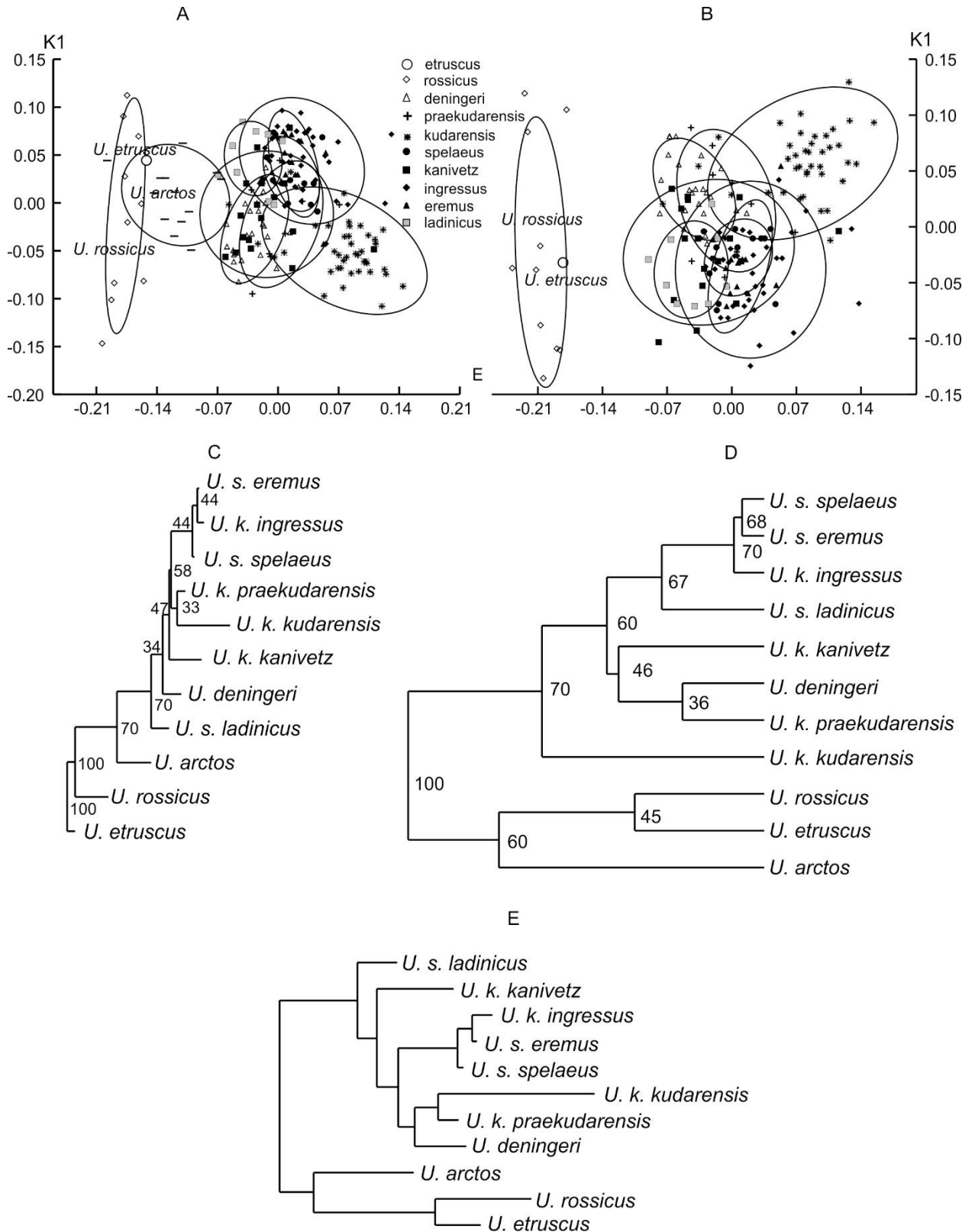

Fig. S20. Scatterplot of the first dimensions of “size” (E1) and “shape” (K1) morphospaces reproduced variation of mtt IV in females: A, C – models with *U. arctos*; B – model without *U. arctos*; C – “size” morphospace; D – NJ tree; E – UGMA dendrogram (cophenetic correlation – 0.89); F – Sattath-Tversky (Sattath, Tversky, 1977) additive tree. All classifications based on the coordinates of samples’ centroids in the “size” (E1, E2) and “shape” (K1, K2) morphospaces (numbers near the nodes - bootstrap (1000 repeats) supports in %). Ellipses’ horizontal and vertical projection onto the E1 (E2) and K1 axes are equal to the “sample mean” (centroid)  $\pm$  “sample range”  $\times$  0.95.

**METATARSAL BONE V (MTT V)****Males and females**

Table S29. Sample numbers (N), means (M), and standard errors (m) of the variables of mtt V among different forms of bears

Form	GL		Bp		Dp		SD	
	N	M±m	N	M±m	N	M±m	N	M±m
<i>U. etruscus</i>	1	75.5					1	10.5
<i>U. savini</i>	1	76.1	1	28.0	1	29.2	1	13.9
<i>U. deningeri</i>	33	83.5±1.12	30	28.4±0.60	33	30.5±0.67	35	13.6±0.24
<i>U. k. praekudarensis</i>	17	92.1±1.39	17	31.0±0.81	18	31.0±0.71	22	15.3±0.33
<i>U. k. kudarensis</i>	45	93.4±0.61	56	33.6±0.30	58	34.1±0.39	60	16.1±0.15
<i>U. rossicus</i>	17	64.6±0.61	13	23.4±0.36	14	25.1±0.51	15	11.2±0.15
<i>U. s. spelaeus</i>	11	90.0±2.24	9	28.4±0.89	11	28.6±0.56	11	14.1±0.44
<i>U. k. kanivetz</i>	36	81.6±1.11	35	28.8±0.52	35	33.4±0.63	36	13.7±0.28
<i>U. s. eremus</i>	20	87.1±1.38	20	29.5±0.69	20	31.3±0.89	20	13.6±0.33
<i>U. s. ladinicus</i>	8	79.5±1.05	6	25.6±0.47	8	27.3±0.96	8	12.4±0.24
<i>U. k. ingressus</i>	37	90.8±0.91	13	30.5±0.82	13	31.3±1.06	37	14.2±0.19
<i>U. arctos</i>	23	86.8±2.39	21	24.4±0.93	18	27.0±1.15	23	11.9±0.43
		Bd		Dd				
		N	M±m	N	M±m			
<i>U. etruscus</i>		1	17.5	1	13.4			
<i>U. savini</i>		1	22.3	1	15.1			
<i>U. deningeri</i>		35	22.9±0.38	34	17.7±0.25			
<i>U. k. praekudarensis</i>		19	25.0±0.60	21	19.4±0.48			
<i>U. k. kudarensis</i>		44	25.9±0.25	43	20.0±0.17			
<i>U. rossicus</i>		18	18.4±0.17	14	13.6±0.14			
<i>U. s. spelaeus</i>		11	23.6±0.67	5	18.4±0.51			
<i>U. k. kanivetz</i>		36	27.7±0.50	33	19.9±0.34			
<i>U. s. eremus</i>		20	23.7±0.42	19	18.8±0.30			
<i>U. s. ladinicus</i>		7	21.0±0.47	7	17.4±0.27			
<i>U. k. ingressus</i>		36	24.2±0.33	30	19.1±0.23			
<i>U. arctos</i>		23	19.8±0.57	17	16.0±0.53			

## Sexual size dimorphism

Table S30. Sexual size dimorphism (SSD and ASSD) of mtt V in the different forms of cave bears and brown bear; *p* based on Mann-Whitney U Test; *v*, % - relative variance associated with SSD.

	Measures						ASSD
	GL	Bp	Dp	SD	Bd	Dd	
<i>U. deningeri</i>							
Males	91.7±1.66	32.0±0.58	34.2±1.19	15.0±0.49	25.0±0.63	19.1±0.36	
Females	79.9±0.48	26.6±0.47	28.9±0.56	13.0±0.19	22.1±0.34	17.1±0.22	
SSD	6.9±1.01 ( <i>p</i> <0.001)	9.2±1.28 ( <i>p</i> <0.001)	8.3±2.09 ( <i>p</i> <0.001)	6.9±1.87 ( <i>p</i> <0.001)	6.3±1.53 ( <i>p</i> <0.001)	5.7±1.18 ( <i>p</i> <0.001)	7.2
<i>v</i> , %	85.2	77.9	55.4	56.9	53.8	58.9	
<i>U. rossicus</i>							
Males	66.1±0.44	23.5±0.37	24.9±0.59	11.2±0.16	18.4±0.24	13.6±0.17	
Females	61.9±0.55	23.3±1.13	25.7±1.12	11.1±0.45	18.3±0.24	13.6±0.23	
SSD	3.3±0.55 ( <i>p</i> =0.001)	n.s.	n.s.	n.s.	n.s.	n.s.	0.6
<i>v</i> , %	82.7	-	-	-	-	-	
<i>U. k. praekudarensis</i>							
Males	94.9±1.15	32.9±0.4	32.1±1.75	16.4±0.20	26.5±0.36	20.2±0.48	
Females	85.4±1.19	26.6±0.98	28.2±0.79	15.6±0.18	22.0±0.81	17.5±0.79	
SSD	5.3±0.92 ( <i>p</i> =0.003)	10.5±1.9 ( <i>p</i> =0.002)	6.5±1.82 ( <i>p</i> =0.014)	9.1±1.84 ( <i>p</i> =0.002)	9.3±1.83 ( <i>p</i> <0.001)	7.3±2.46 ( <i>p</i> =0.017)	8.0
<i>v</i> , %	82.7	86.1	44.4	76.4	77.1	28.8	
<i>U. k. kudarensis</i>							
Males	95.8±0.44	34.7±0.36	34.9±0.52	19.9±0.22	26.4±0.26	20.2±0.21	
Females	88.9±0.58	32.1±0.33	32.9±0.49	17.1±0.5	25.0±0.41	19.6±0.26	
SSD	3.7±0.40 ( <i>p</i> <0.001)	3.8±0.73 ( <i>p</i> <0.001)	3.0±1.1 ( <i>p</i> =0.011)	2.2±0.83 ( <i>p</i> =0.02)	2.8±0.95 ( <i>p</i> =0.004)	1.7±0.83 ( <i>p</i> =0.03)	2.9
<i>v</i> , %	81.9	38.1	6.4	12.6	25.0	13.4	
<i>U. s. spelaeus</i>							
Males	95.8±1.61	30.0±0.91	29.8±0.50	15.2±0.27	25.3±0.46	20.0*	
Females	83.1±1.37	27.2±1.24	27.2±1.24	12.8±0.40	21.6±0.44	18.0±0.41	
SSD	7.1±1.18 ( <i>p</i> =0.008)	n.s.	4.8±1.38 ( <i>p</i> =0.02)	8.6±1.73 ( <i>p</i> =0.008)	8.0±1.36 ( <i>p</i> =0.008)	n.s.	6.5
<i>v</i> , %	87.5	0.0	54.6	33.2	73.9	-	
<i>U. s. ladinicus</i>							
Males	81.8±0.65	26.8±0.90	29.4±1.07	12.9±0.33	22.2±0.23	17.7±0.41	
Females	77.2±1.09	25.0±0.28	25.3±0.57	12.0±0.17	20.1±0.36	16.9±0.07	
SSD	2.9±0.08 ( <i>p</i> =0.03)	n.s.	7.5±2.23 ( <i>p</i> =0.03)	n.s.	n.s.	n.s.	4.7
<i>v</i> , %	75.5	-	79.0	-	-	-	
<i>U. s. eremus</i>							
Males	92.1±1.14	32.0±0.65	34.9±0.53	14.7±0.35	25.3±0.22	20.0±0.80	
Females	82.2±1.15	27.0±0.52	27.7±0.44	12.5±0.22	22.0±0.32	17.6±0.21	
SSD	5.6±0.93 ( <i>p</i> <0.001)	8.3±1.32 ( <i>p</i> <0.001)	11.5±1.11 ( <i>p</i> <0.001)	8.2±1.54 ( <i>p</i> =0.002)	6.9±0.82 ( <i>p</i> <0.001)	6.3±0.74 ( <i>p</i> <0.001)	7.8
<i>v</i> , %	78.3	77.2	91.5	73.3	87.4	87.9	
<i>U. k. ingressus</i>							
Males	95.4±0.73	32.9±0.51	34.0±1.17	15.0±0.18	25.8±0.30	21.0±0.26	
Females	86.0±0.55	27.8±0.60	28.3±0.68	13.3±0.20	22.6±0.23	18.1±0.13	

	Measures						ASSD
	GL	Bp	Dp	SD	Bd	Dd	
<i>SSD</i>	5.2±0.50 ( <i>p</i> <0.001)	8.4±1.30 ( <i>p</i> =0.003)	9.1±2.19 ( <i>p</i> =0.01)	5.9±0.95 ( <i>p</i> <0.001)	6.5±0.79 ( <i>p</i> <0.001)	5.2±0.77 ( <i>p</i> <0.001)	6.7
<i>v, %</i>	81.8	88.3	61.5	71.8	77.4	86.1	
<i>U. k. kanivetz</i>							
Males	89.1±0.76	32.7±0.39	37.4±0.83	15.7±0.42	30.0±0.95	21.1±0.83	7.6
Females	77.9±0.94	27.0±0.33	31.6±0.49	12.7±0.14	26.6±0.43	19.3±0.28	
<i>SSD</i>	6.7±0.72 ( <i>p</i> <0.001)	9.6±0.86 ( <i>p</i> <0.001)	8.5±1.40 ( <i>p</i> <0.001)	10.3±1.57 ( <i>p</i> <0.001)	6.0±1.84 ( <i>p</i> =0.002)	4.2±2.17 ( <i>p</i> =0.005)	
<i>v, %</i>	77.0	87.6	77.4	84.7	75.4	33.9	
<i>U. arctos</i>							
Males	92.5±3.51	26.7±1.25	29.1±1.53	13.1±0.58	21.4±0.81	17.3±0.62	7.5
Females	82.4±2.80	22.6±1.12	24.8±1.45	11.0±0.51	18.6±0.63	14.8±0.64	
<i>SSD</i>	5.7±2.57 ( <i>p</i> =0.02)	8.3±3.41 ( <i>p</i> =0.01)	n.s.	8.5±3.21 ( <i>p</i> =0.02)	6.9±2.56 ( <i>p</i> =0.01)	7.7±2.78 ( <i>p</i> =0.002)	
<i>v, %</i>	12.5	21.2	27.4	19.7	23.8	45.3	



Univariate analysis

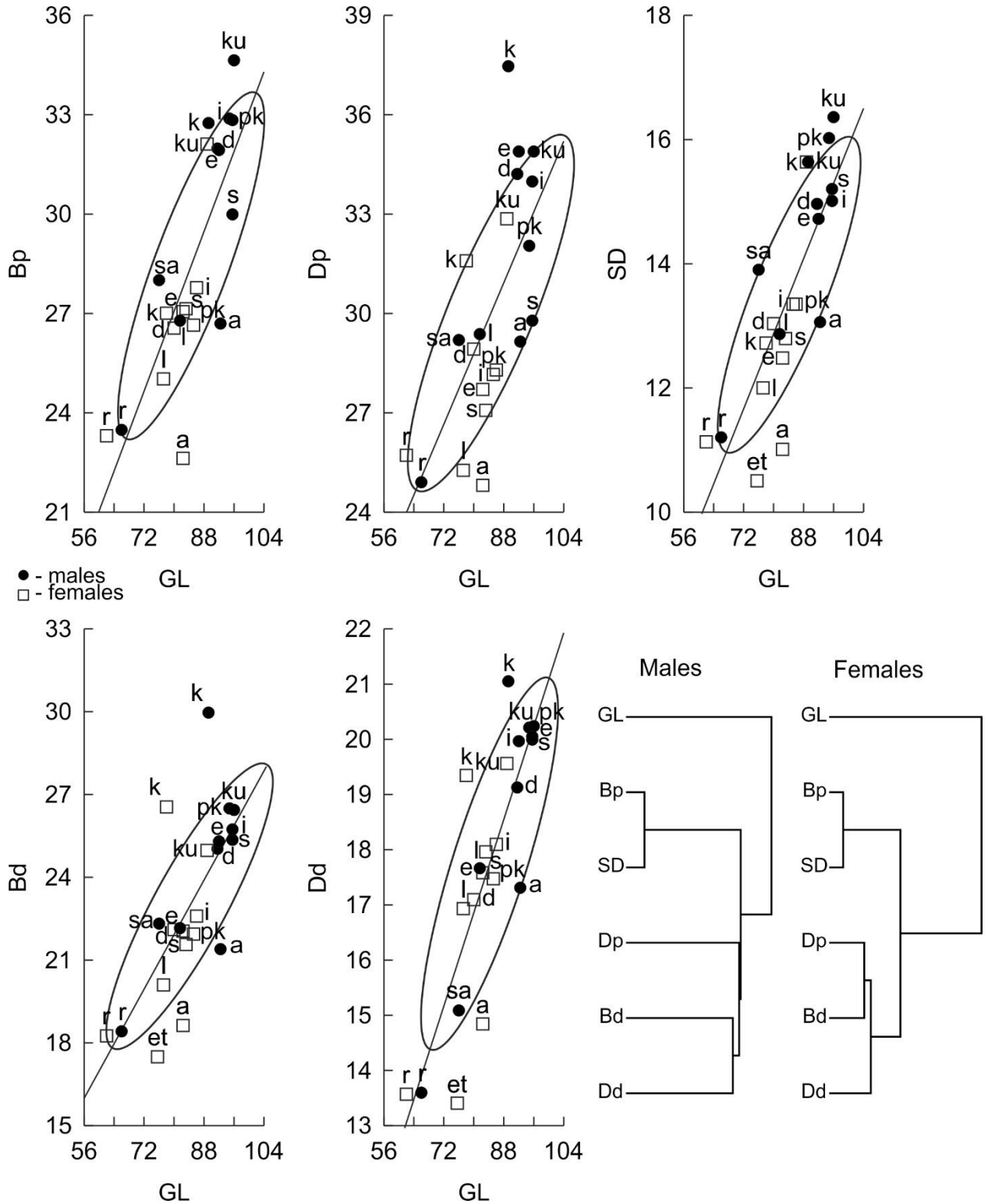

Fig. S21. The scatterplots of measures (GL – Dd) of mtt V and their classification: et – *U. etruscus*, a – *U. arctos*, sa – *U. savini*, r – *U. rossicus*, d – *U. deningeri*, pk – *U. k. praekudarensis*, ku – *U. k. kudarensis*, s – *U. s. spelaeus*, k – *U. k. kanivetz*, i – *U. k. ingressus*, e – *U. s. eremus*, l – *U. s. ladinicus*.

Table S31. Statistical parameters of measures of mtt V among different bears and sexes: m – males, f – females.

Taxa	Sex	GL - N	GL	GL Std.Dev.	Bp - N	Bp	Bp Std.Dev.	Dp - N	Dp	Dp Std.Dev.	SD - N	SD	SD Std.Dev.	Bd - N	Bd	Bd Std.Dev.	Dd - N	Dd	Dd Std.Dev.
<i>U. etruscus</i>	f	1	75.5								1	10.5		1	17.5		1	13.4	
<i>U. savini</i>	m	1	76.1		1	28.0		1	29.2	0.00	1	13.9		1	22.3		1	15.1	
<i>U. rossicus</i>	f	6	61.9	1.34	3	23.3	1.95	3	25.7	1.93	3	11.1	0.78	6	18.3	0.59	3	13.6	0.40
	m	11	66.1	1.46	10	23.5	1.17	11	24.9	1.97	12	11.2	0.55	12	18.4	0.82	11	13.6	0.55
<i>U. deningeri</i>	f	23	79.9	2.31	20	26.6	2.09	23	28.9	2.68	25	13.0	0.97	25	22.1	1.72	24	17.1	1.07
	m	10	91.7	5.25	10	32.0	1.85	10	34.2	3.76	10	15.0	1.54	10	25.0	2.00	10	19.1	1.15
<i>U. k. praekudarensis</i>	f	5	85.4	2.65	5	26.6	2.20	5	28.2	1.77	6	13.4	1.19	6	22.0	1.98	6	17.5	1.94
	m	12	94.9	4.00	12	32.9	1.38	13	32.1	2.72	16	16.0	0.93	13	26.5	1.30	15	20.2	1.84
<i>U. k. kudarensis</i>	f	16	88.9	2.32	23	32.1	1.57	23	32.9	2.34	23	15.6	0.85	16	25.0	1.65	15	19.6	1.00
	m	29	95.8	2.39	33	34.7	2.06	35	34.9	3.06	37	16.4	1.21	28	26.4	1.40	28	20.2	1.09
<i>U. s. spelaeus</i>	f	5	83.1	3.06	5	27.2	2.78	5	27.1	1.34	5	12.8	0.90	5	21.6	0.98	4	18.0	0.82
	m	6	95.8	3.94	4	30.0	1.62	6	29.8	1.22	6	15.2	0.65	6	25.3	1.13	1	20.0	0.00
<i>U. k. ingressus</i>	f	18	86.0	2.31	6	27.8	1.47	6	28.3	1.67	18	13.3	0.86	18	22.6	0.99	15	18.1	0.51
	m	19	95.4	3.19	7	32.9	1.36	7	34.0	3.10	19	15.0	0.76	18	25.8	1.28	15	20.1	1.01
<i>U. k. kanivetz</i>	f	24	77.9	4.60	24	27.0	1.60	24	31.6	2.41	24	12.7	0.67	24	26.6	2.12	23	19.3	1.34
	m	12	89.1	2.62	11	32.7	1.30	11	37.4	2.75	12	15.7	1.46	12	30.0	3.28	10	21.1	2.63
<i>U. s. eremus</i>	f	10	82.2	3.64	10	27.0	1.63	10	27.7	1.39	10	12.5	0.71	10	22.0	1.00	10	17.6	0.67
	m	10	92.1	3.60	10	32.0	2.06	10	34.9	1.69	10	14.7	1.12	10	25.3	0.70	10	20.0	0.56
<i>U. s. ladinicus</i>	f	4	77.2	2.18	4	25.0	0.55	4	25.3	1.14	4	12.0	0.35	4	20.1	0.71	3	16.9	0.12
	m	4	81.8	1.29	2	26.8	1.27	4	29.4	2.15	4	12.9	0.66	3	22.2	0.40	4	17.7	0.82
<i>U. arctos</i>	f	13	82.4	10.1	12	22.6	3.87	9	24.8	4.36	13	11.0	1.84	13	18.6	2.28	9	14.8	1.92
	m	10	92.5	11.1	9	26.7	3.75	9	29.1	4.60	10	13.1	1.82	10	21.4	2.55	8	17.3	1.75

Table S32. Kruskal-Wallis test  $z'$  values (males - above diagonal and females – under diagonal) for GL and BP of mtt V between bear taxa. The statistical significance values, according to 2-tailed  $p$  values, have been underlined.

Taxa		1	2	3	4	5	6	7	8	9	10
GL											
<i>U. deningeri</i>	1		3.22	1.34	2.18	1.57	1.71	1.28	0.12	1.95	0.03
<i>U. rossicus</i>	2	2.63		<u>4.74</u>	<u>6.23</u>	<u>4.36</u>	<u>5.47</u>	2.06	3.09	0.43	3.19
<i>U. k. praekudarensis</i>	3	2.32	<u>3.88</u>		0.66	0.47	0.25	2.75	1.47	3.00	1.37
<i>U. k. kudarensis</i>	4	<u>5.34</u>	<u>6.15</u>	1.15		0.02	0.45	<u>3.92</u>	2.33	<u>3.67</u>	2.22
<i>U. s. spelaeus</i>	5	1.48	3.19	0.66	1.97		0.30	2.71	1.67	<u>3.04</u>	1.59
<i>U. k. ingressus</i>	6	<u>4.05</u>	<u>5.26</u>	0.25	1.35	1.08		<u>3.29</u>	1.85	3.32	1.74
<i>U. k. kanivetz</i>	7	0.75	2.16	2.78	<u>6.06</u>	1.93	<u>4.79</u>		1.15	1.06	1.25
<i>U. s. eremus</i>	8	1.36	3.33	1.15	3.03	0.39	1.92	1.95		1.86	0.09
<i>U. s. ladinicus</i>	9	1.02	1.01	2.53	<u>4.09</u>	1.91	<u>3.30</u>	0.61	1.80		1.93
<i>U. arctos</i>	10	0.80	3.01	1.65	<u>3.91</u>	0.86	2.73	1.45	0.56	1.45	
Bp											
<i>U. deningeri</i>	1		3.10	0.68	2.67	1.10	0.63	0.58	0.03	1.41	2.09
<i>U. rossicus</i>	2	1.56		<u>3.92</u>	<u>6.51</u>	1.24	<u>3.44</u>	<u>3.75</u>	3.07	0.38	0.93
<i>U. k. praekudarensis</i>	3	0.06	1.36		2.00	1.63	0.04	0.09	0.71	1.81	2.84
<i>U. k. kudarensis</i>	4	<u>5.18</u>	<u>4.16</u>	3.15		3.05	1.57	2.05	2.71	<u>2.83</u>	<u>5.12</u>
<i>U. s. spelaeus</i>	5	0.36	1.57	0.23	2.85		1.53	1.55	1.08	0.51	0.51
<i>U. k. ingressus</i>	6	1.10	2.09	0.80	2.34	0.55		0.12	0.66	1.75	2.52
<i>U. k. kanivetz</i>	7	0.65	1.90	0.34	<u>4.75</u>	0.04	0.69		0.61	1.75	2.70
<i>U. s. eremus</i>	8	0.65	1.85	0.40	<u>3.52</u>	0.13	0.50	0.14		1.40	2.06
<i>U. s. ladinicus</i>	9	1.15	0.44	0.98	<u>4.09</u>	1.20	1.77	1.53	1.49		0.17
<i>U. arctos</i>	10	2.62	0.01	1.85	<u>7.14</u>	2.13	2.94	<u>3.27</u>	2.82	0.57	
Dp											
<i>U. deningeri</i>	1		<u>3.97</u>	1.24	0.52	2.16	0.08	1.83	0.53	2.02	2.20
<i>U. rossicus</i>	2	1.51		2.97	<u>5.56</u>	1.22	<u>3.68</u>	<u>5.95</u>	<u>4.52</u>	0.93	1.61
<i>U. k. praekudarensis</i>	3	0.35	1.03		2.17	1.21	1.20	3.22	1.80	1.18	1.13
<i>U. k. kudarensis</i>	4	<u>3.96</u>	<u>3.41</u>	2.72		2.95	0.35	1.78	0.15	2.61	3.20
<i>U. s. spelaeus</i>	5	1.15	0.49	0.62	<u>3.52</u>		2.08	<u>3.78</u>	2.62	0.12	0.20
<i>U. k. ingressus</i>	6	0.44	1.02	0.05	2.99	0.60		1.57	0.40	1.97	2.09
<i>U. k. kanivetz</i>	7	2.91	2.90	2.08	1.09	2.88	2.31		1.29	<u>3.42</u>	<u>4.03</u>
<i>U. s. eremus</i>	8	1.01	0.83	0.38	<u>4.09</u>	0.34	0.35	<u>3.27</u>		2.42	2.72
<i>U. s. ladinicus</i>	9	2.13	0.30	1.46	<u>4.28</u>	0.87	1.47	<u>3.71</u>	1.30		0.30
<i>U. arctos</i>	10	2.38	0.02	1.37	<u>5.35</u>	0.66	1.39	<u>4.57</u>	1.21	0.36	
SD											
<i>U. deningeri</i>	1		<u>3.26</u>	1.77	2.46	0.34	0.06	0.92	0.59	1.83	1.84
<i>U. rossicus</i>	2	2.17		<u>5.53</u>	<u>6.84</u>	3.15	<u>3.85</u>	<u>4.39</u>	2.65	0.54	1.34
<i>U. k. praekudarensis</i>	3	0.36	2.11		0.53	1.12	2.04	0.84	2.43	3.22	<u>3.82</u>
<i>U. k. kudarensis</i>	4	<u>4.84</u>	<u>4.44</u>	2.70		1.58	3.02	1.44	3.19	<u>3.72</u>	<u>4.77</u>
<i>U. s. spelaeus</i>	5	0.46	1.51	0.64	<u>3.29</u>		0.33	0.44	0.85	1.96	1.94
<i>U. k. ingressus</i>	6	0.86	2.56	0.22	<u>3.60</u>	0.97		1.01	0.73	2.02	2.17
<i>U. k. kanivetz</i>	7	0.81	1.79	0.86	<u>5.59</u>	0.01	1.60		1.54	2.56	2.85
<i>U. s. eremus</i>	8	1.16	1.36	1.15	<u>4.84</u>	0.38	1.78	0.54		1.39	1.25
<i>U. s. ladinicus</i>	9	1.83	0.45	1.78	<u>4.40</u>	1.13	2.27	1.40	0.93		0.44
<i>U. arctos</i>	10	<u>3.45</u>	0.23	2.72	<u>7.43</u>	1.81	<u>3.97</u>	2.75	1.77	0.34	
Bd											
<i>U. deningeri</i>	1		3.11	1.60	1.76	0.12	0.84	3.08	0.15	1.51	2.18
<i>U. rossicus</i>	2	2.62		<u>5.01</u>	<u>5.74</u>	2.79	<u>4.47</u>	<u>6.49</u>	<u>3.26</u>	0.53	0.83
<i>U. k. praekudarensis</i>	3	0.22	1.89		0.07	1.24	0.93	1.62	1.44	2.60	<u>3.92</u>

Taxa		1	2	3	4	5	6	7	8	9	10
<i>U. k. kudarensis</i>	4	<u>3.35</u>	<u>4.73</u>	2.45		1.31	1.05	1.94	1.59	2.70	<u>4.41</u>
<i>U. s. spelaeus</i>	5	0.49	1.57	0.24	2.57		0.57	2.51	0.01	1.49	2.01
<i>U. k. ingressus</i>	6	0.79	3.04	0.72	2.42	0.96		2.65	0.68	2.12	<u>3.32</u>
<i>U. k. kanivetz</i>	7	<u>5.06</u>	<u>5.77</u>	<u>3.38</u>	1.15	<u>3.43</u>	<u>3.86</u>		2.93	<u>3.58</u>	<u>5.36</u>
<i>U. s. eremus</i>	8	0.04	2.27	0.16	2.70	0.41	0.65	<u>3.88</u>		1.61	2.33
<i>U. s. ladinicus</i>	9	1.53	0.57	1.12	<u>3.39</u>	0.87	1.93	<u>4.20</u>	1.37		0.02
<i>U. arctos</i>	10	3.04	0.31	1.90	<u>5.66</u>	1.51	<u>3.52</u>	<u>7.21</u>	2.43	0.37	
Dd											
<i>U. deningeri</i>	1		2.77	2.19	1.84	0.49	1.46	2.85	0.99	1.12	1.21
<i>U. rossicus</i>	2	1.67		<u>5.31</u>	<u>5.31</u>	1.65	<u>4.55</u>	<u>5.69</u>	<u>3.78</u>	0.94	1.37
<i>U. k. praekudarensis</i>	3	0.53	1.79		0.68	0.37	0.82	0.93	1.11	2.77	<u>3.36</u>
<i>U. k. kudarensis</i>	4	<u>4.78</u>	<u>4.10</u>	2.75		0.16	0.26	1.62	0.64	2.51	3.13
<i>U. s. spelaeus</i>	5	1.06	2.08	0.51	1.78		0.08	0.73	0.07	1.05	1.03
<i>U. k. ingressus</i>	6	1.94	2.62	0.81	2.56	0.12		1.67	0.37	2.24	2.67
<i>U. k. kanivetz</i>	7	<u>5.21</u>	<u>4.14</u>	2.79	0.15	1.75	2.66		1.87	<u>3.28</u>	<u>3.90</u>
<i>U. s. eremus</i>	8	0.63	1.91	0.01	<u>3.27</u>	0.57	0.98	<u>3.39</u>		1.87	2.14
<i>U. s. ladinicus</i>	9	0.38	0.97	0.67	2.85	1.05	1.37	2.85	0.71		0.15
<i>U. arctos</i>	10	1.74	0.51	1.75	<u>5.34</u>	2.08	3.12	<u>5.60</u>	1.99	0.67	

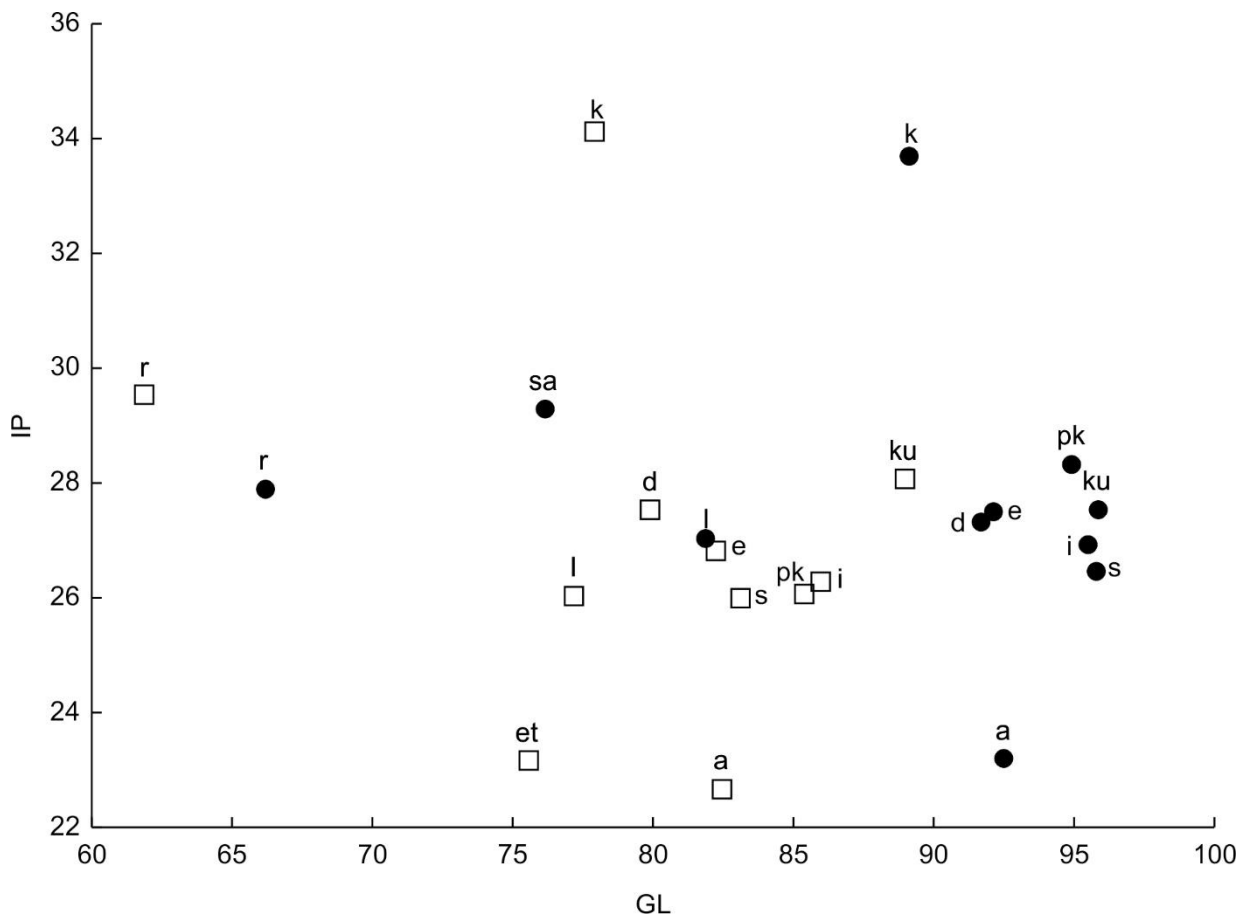

Fig. S22. The scatterplot of Index plumpness (ip) and GL of mtt V: et – *U. etruscus*, a – *U. arctos*, r – *U. rossicus*, d – *U. deningeri*, pk – *U. k. praekudarensis*, ku – *U. k. kudarensis*, s – *U. s. spelaeus*, k – *U. k. kanivetz*, i – *U. k. ingressus*, e – *U. s. eremus*, l – *U. s. ladinicus*. Point – males, square – females.

**Multivariate analyses**

Table S33. Description of the modeled morphological spaces for cave bears and brown bear mtt V. Correlation coefficients among the measures and dimensions of two morphospace models (MDS axes: E1–E2, K1–K2);  $r^2$  – coefficients of determination in the linear multiple regression models.

Measures	Morphospaces with <i>U. arctos</i>				$r^2$	Morphospaces without <i>U. arctos</i>				$r^2$
	“Size”		“Shape”			“Size”		“Shape”		
	morphospace		morphospace			morphospace		morphospace		
	E1	E2	K1	K2		E1	E2	K1	K2	
GL	0.86	0.50	0.41	0.07	0.92	0.88	0.36	0.46	-0.07	0.91
Bp	0.93	0.28	0.07	0.20	0.91	0.93	0.14	0.30	0.13	0.89
Dp	0.85	-0.29	-0.38	-0.20	0.87	0.83	-0.43	-0.27	0.06	0.90
SD	0.90	0.33	0.06	0.32	0.91	0.91	0.20	0.36	0.20	0.87
Bd	0.89	-0.17	-0.17	-0.21	0.86	0.87	-0.31	-0.09	-0.26	0.86
Dd	0.90	0.03	0.09	-0.29	0.90	0.89	-0.12	0.10	-0.38	0.91
ip	0.20	-0.75	-0.63	-0.39		0.16	-0.78	-0.63	-0.31	
Relative variance (%) of dimensions associated with taxonomical composition										
	62.2	65.5	53.5	45.3		64.7	59.2	51.8	45.2	

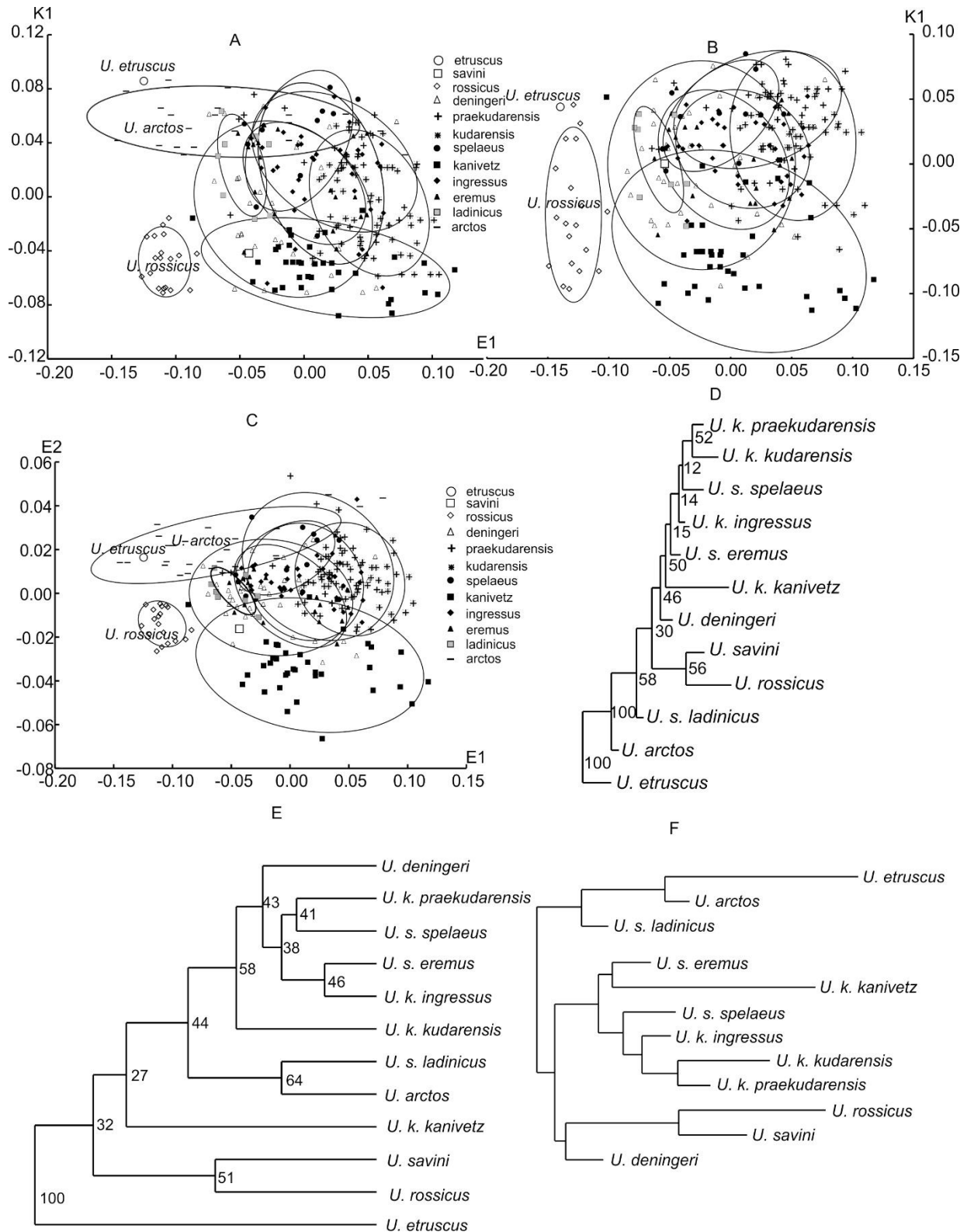

Fig. S23. Scatterplot of the first dimensions of “size” (E1) and “shape” (K1) morphospaces reproduced variation of mtt V in males and females: A, C – models with *U. arctos*; B – model without *U. arctos*; C – “size” morphospace; D – NJ tree; E – UGMA dendrogram (cophenetic correlation – 0.83); F – Sattath-Tversky (Sattath, Tversky, 1977) additive tree. All classifications based on the coordinates of samples’ centroids in the “size” (E1, E2) and “shape” (K1, K2) morphospaces (numbers near the nodes - bootstrap (1000 repeats) supports in %). Ellipses’ horizontal and vertical projection onto the E1 (E2) and K1 axes are equal to the “sample mean” (centroid) ± “sample range” x 0.95.

**Males**

Table S34. Description of the modeled morphological spaces for males of cave bears and brown bear mtt V (males only). Correlation coefficients among the measures and dimensions of two morphospace models (MDS axes: E1–E2, K1–K2);  $r^2$  – coefficients of determination in the linear multiple regression models.

Measures	Morphospaces with <i>U. arctos</i>					Morphospaces without <i>U. arctos</i>					
	“Size”		“Shape”		$r^2$	“Size”		“Shape”		$r^2$	
	morphospace		morphospace			morphospace		morphospace			
	E1	E2	K1	K2	E1	E2	K1	K2	K3		
GL	0.85	0.42	0.26	0.34	0.91	0.87	0.37	0.34	0.48	0.19	0.92
Bp	0.93	0.19	-0.15	0.12	0.89	0.93	0.11	0.26	0.21	0.42	0.94
Dp	0.83	-0.42	-0.06	-0.43	0.92	0.81	-0.49	-0.35	0.05	0.24	0.95
SD	0.89	0.32	-0.28	0.21	0.92	0.89	0.21	0.36	-0.02	0.10	0.93
Bd	0.91	-0.06	-0.06	-0.12	0.84	0.91	-0.16	0.00	0.09	-0.06	0.90
Dd	0.91	0.07	0.19	-0.04	0.89	0.91	-0.01	0.06	0.43	-0.01	0.92
ip	0.31	-0.59	-0.36	-0.57		0.26	-0.66	-0.42	-0.43	-0.36	
Relative variance (%) of dimensions associated with taxonomical composition											
	83.3	48.7	41.3	41.7		89.7	47.7	36.8	40.8	30.4	

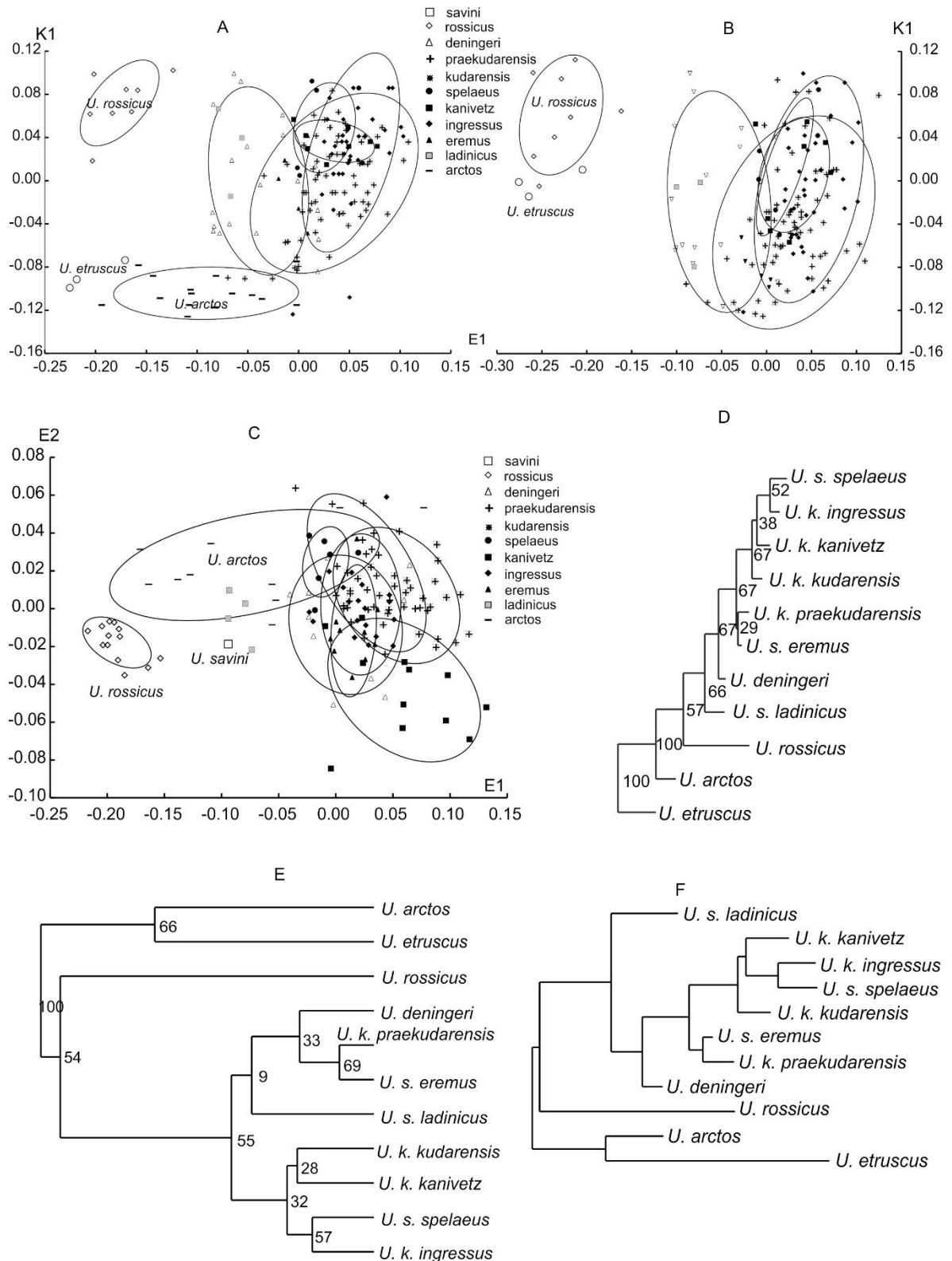

Fig. S24. Scatterplot of the first dimensions of "size" (E1) and "shape" (K1) morphospaces reproduced variation of mtt V in males: A, C – models with *U. arctos*; B – model without *U. arctos*; C – "size" morphospace; D – NJ tree; E – UGMA dendrogram (cophenetic correlation – 0.89); F – Sattath-Tversky (Sattath, Tversky, 1977) additive tree. All classifications based on the coordinates of samples' centroids in the "size" (E1, E2) and "shape" (K1, K2) morphospaces (numbers near the nodes - bootstrap (1000 repeats) supports in %). Ellipses' horizontal and vertical projection onto the E1 (E2) and K1 axes are equal to the "sample mean" (centroid) ± "sample range" x 0.95.



## Females

Table S35. Description of the modeled morphological spaces for females of cave bears and brown bear mtt V. Correlation coefficients among the measures and dimensions of two morphospace models (MDS axes: E1–E2, K1–K3);  $r^2$  – coefficients of determination in the linear multiple regression models.

Measures	Morphospaces with <i>U. arctos</i>					$r^2$	Morphospaces without <i>U. arctos</i>				$r^2$
	“Size” morphospace		“Shape” morphospace				“Size” morphospace		“Shape” morphospace		
	E1	E2	K1	K2	K3		E1	E2	K1	K2	
GL	0.63	0.58	0.19	0.43	-0.06	0.88	0.72	0.48	0.52	0.18	0.86
Bp	0.84	0.41	0.27	0.03	-0.40	0.94	0.87	0.20	0.33	0.06	0.85
Dp	0.78	-0.36	-0.42	-0.48	0.00	0.94	0.73	-0.50	-0.41	-0.07	0.88
SD	0.76	0.44	0.35	-0.13	-0.18	0.89	0.81	0.27	0.39	-0.21	0.89
Bd	0.83	-0.43	-0.53	-0.22	-0.55	0.94	0.76	-0.59	-0.42	0.46	0.93
Dd	0.88	-0.17	-0.44	0.09	-0.47	0.93	0.85	-0.35	-0.18	0.51	0.89
ip	0.43	-0.79	-0.65	-0.48	-0.49		0.30	-0.89	-0.74	0.33	
Relative variance (%) of dimensions associated with taxonomical composition											
	74.6	77.2	60.8	50.4	33.2		79.6	77.4	68.5	40.3	

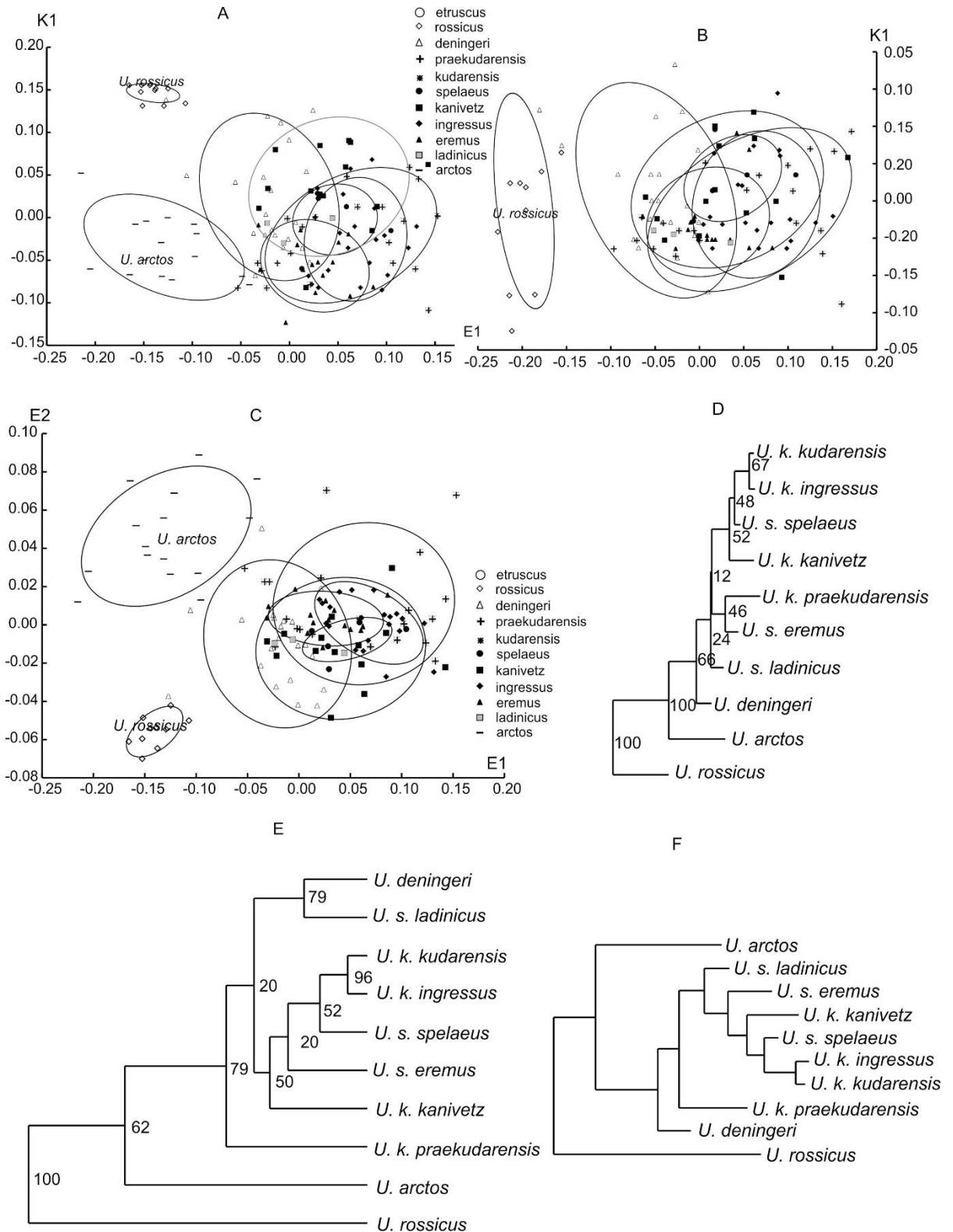

Fig. S25. Scatterplot of the first dimensions of “size” (E1) and “shape” (K1) morphospaces reproduced variation of mtt V in females: A, C – models with *U. arctos*; B – model without *U. arctos*; C – “size” morphospace; D – NJ tree; E – UGMA dendrogram (cophenetic correlation – 0.95); F – Sattath-Tversky (Sattath, Tversky, 1977) additive tree. All classifications based on the coordinates of samples’ centroids in the “size” (E1, E2) and “shape” (K1, K2) morphospaces (numbers near the nodes - bootstrap (1000 repeats) supports in %). Ellipses’ horizontal and vertical projection onto the E1 (E2) and K1 axes are equal to the “sample mean” (centroid) ± “sample range” x 0.95.